

Public Records of  
St. Johns County, FL  
Clerk# 02-019335  
O.R. 1739 PG 1776  
04:27PM 04/02/2002  
REC \$385.00 SUR \$48.50

**COPY**  
**FIVE MINUTE RECORDING**  
**DECLARATION OF CONDOMINIUM**

**OF**

**OCEAN GRANDE AT SERENATA BEACH,**

**A CONDOMINIUM**

*Isk*

Prepared by and return to:  
Charles L. Cranford  
Rogers, Towers Bailey, Jones & Gay, P.A.  
1301 Riverplace Boulevard, Suite 1500  
Jacksonville, Florida 32207

**DECLARATION OF CONDOMINIUM OF  
OCEAN GRANDE AT SERENATA BEACH, A CONDOMINIUM**

CONTENTS

I.	Submission Statement .....	1
II.	Definitions .....	1
III.	Units; Appurtenances; Possession and Enjoyment .....	3
IV.	Restraint Upon Separation and Partition of Common Elements .....	5
V.	Common Elements and Limited Common Elements .....	5
VI.	Condominium Property and Identification of Units .....	6
VII.	Ownership of Common Elements and Shares of Common Surplus .....	6
VIII.	Amendment to Declaration .....	7
IX.	The Association: Its Powers and Responsibilities .....	8
X.	Maintenance, Alterations and Improvements .....	10
XI.	Enforcement of Maintenance .....	12
XII.	Common Expenses .....	12
XIII.	Assessments: Liability, Lien and Priority; Interest; Collection .....	13
XIV.	Maintenance Guarantee .....	15
XV.	Limitation of Liability .....	16
XVI.	Liens .....	16
XVII.	Easements .....	17
XVIII.	Obligations of Unit Owners .....	18
XIX.	Insurance .....	19

XX. Eminent Domain or Condemnation Proceedings ..... 24

XXI. Rules and Regulations ..... 24

XXII. Management Agreement ..... 25

XXIII. Termination of Condominium ..... 25

XXIV. Assignability of Rights of Developer ..... 26

XXV. Execution of Documents Required by St. Johns County  
and/or by the State of Florida ..... 26

XXVI. Developer's Right to Amend Declaration of Condominium ..... 26

XXVII. Use Restrictions ..... 27

XXVIII. Condominium Working Capital Fund ..... 29

XXIX. Leases of Units ..... 29

XXX. Remedies ..... 30

XXXI. Provisions for a Phase Condominium ..... 31

XXXII. Additional Provisions ..... 33

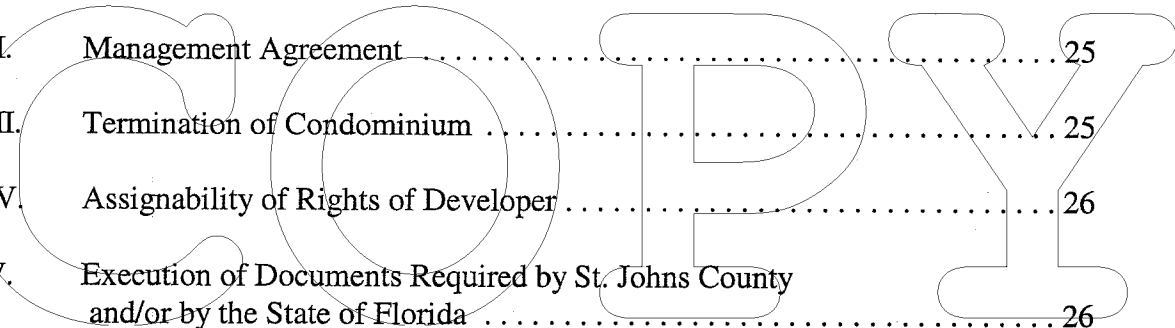

**DECLARATION OF CONDOMINIUM  
OF**

**OCEAN GRANDE AT SERENATA BEACH,  
A CONDOMINIUM**

**I. SUBMISSION STATEMENT**

OCEAN GRANDE SERENATA, L.L.C., a Florida limited liability company (hereinafter called the "Developer") is the owner, in fee simple, of the real property legally described in Exhibit "A" attached hereto. Developer does hereby submit the real property described in Exhibit "A" attached hereto, the improvements thereon and the rights and easements appurtenant thereto to condominium ownership pursuant to Chapter 718, Florida Statutes and declares same a condominium known as OCEAN GRANDE AT SERENATA BEACH, a Condominium (the "Condominium").

All of the restrictions, reservations, covenants, conditions and easements contained herein shall constitute covenants running with the land or equitable servitudes upon the land, as the case may be, and shall be binding on each Unit Owner, and each Unit Owner's heirs, personal representatives, successors and assigns. Both the burdens imposed and the benefits provided shall run with the title to each Unit and their appurtenant interests in the Common Elements as defined herein.

**II. DEFINITIONS:**

As used herein and in the Exhibits attached hereto and in all amendments thereto, unless the context requires otherwise:

- A. "Act" means and refers to the Condominium Act of the State of Florida in effect on the date of recordation of this Declaration of Condominium.
- B. "Assessment" means the share of the funds required for the payment of Common Expenses which from time to time are assessed against a Unit Owner.
- C. "Association" or "Corporation" means OCEAN GRANDE CONDOMINIUM ASSOCIATION, INC., a Florida corporation not for profit, the entity responsible for the operation of the Condominium.
- D. "Board" or "Board of Directors" means the Board of Directors of the Association.
- E. "By-Laws" means the By-Laws of the Association.
- F. "Condominium Documents" means this Declaration and all Exhibits attached hereto as the same, from time to time, may be amended.



G. "Condominium Property" means and includes the land submitted to condominium ownership, whether or not contiguous, all improvements thereon, and all easements and rights appurtenant thereto intended for use in connection with the Condominium.

H. "Condominium Unit" or "Unit" means that portion of the Condominium Property which is to be subject to exclusive ownership as a dwelling space as identified on the Plot Plan, Survey and Graphic Description attached hereto as Exhibit "B," together with the garage space which is initially conveyed by Developer with the Unit.

I. "Common Elements" means the portion of the Condominium Property not included in the Units, if any.

J. "Common Expenses" means: (1) expenses of administration and management of the Condominium Property; (2) expenses of maintenance, operation, repair or replacement of the Common Elements; (3) expenses declared Common Expenses by the provisions of this Declaration or the By-Laws; and (4) any valid charge against the Condominium as a whole.

K. "Common Surplus" means the excess of all receipts of the Association collected on behalf of the Condominium, (including, but not limited to, Assessments, rents, profits and revenues) over and above the amount of money expended as Common Expenses.

L. "Condominium" means that form of ownership of real property created pursuant to the provisions of the Act which is comprised of Units that may be owned by one or more persons or entities and where there is appurtenant to each Unit, as part thereof, an undivided share in the Common Elements.

M. "Condominium Parcel" means a Unit together with the undivided share in the Common Elements which is appurtenant to the Unit.

N. "Declaration" or "Declaration of Condominium" means this instrument, and all Exhibits attached hereto, as same may from time to time be amended.

O. "Developer" means OCEAN GRANDE SERENATA, L.L.C., a Florida limited liability company and such assigns as may be designated in writing by OCEAN GRANDE SERENATA, L.L.C., a Florida limited liability company, pursuant to the provisions of Article XXIV hereinafter.

P. "Garage" means that portion of the Condominium Property identified on the Plat Plan, Survey and Graphic Description attached hereto as Exhibit B as a garage by a designation beginning with a "G." Garages shall be Limited Common Elements.

Q. "Institutional Lender" or "Institutional Mortgagee" means the Developer, a bank, savings and loan association, insurance company, a generally recognized and licensed mortgage company, real estate investment trust, public company pension fund, public company pension trust, the Federal Home Loan Mortgage Corporation, the Federal National Mortgage Association, or any other generally recognized institutional-type lender or its loan correspondent, or any agency of the United States Government or any lender providing funds to the Developer for the

purpose of constructing improvements upon the Condominium Property (and such lender's successors and assigns) holding a mortgage encumbering a Unit.

R. "Institutional Mortgage" means a mortgage encumbering a Unit held by an Institutional Lender or by an Institutional Mortgagee.

S. "Insurance Trustee" means that Florida Bank having trust powers, designated by the Board to receive proceeds on behalf of the Association, which proceeds are paid as a result of casualty or fire loss covered by insurance policies.

T. "Limited Common Elements" means those Common Elements which are reserved for the use of a certain Unit or certain Units to the exclusion of all other Units.

U. "Storage Room" means that portion of the Condominium Property identified on the Plot Plan, Survey and Graphic Description attached hereto as Exhibit B as a storage room by a designation beginning with an "S." Storage Rooms shall be Limited Common Elements.

V. "Unit Owner" or "Owner" means that person or entity owning a Unit.

### III. UNITS; GARAGES, STORAGE ROOMS; APPURTENANCES; POSSESSION AND ENJOYMENT

A. A Unit is a separate parcel of real property, the ownership of which may be in fee simple, or any other estate in real property recognized by law.

B. The upper and lower boundaries of the Unit, the Garage and the Storage Room shall be the following boundaries extended to an intersection with the perimetrical boundaries:

1. Upper Boundaries -- the horizontal plane of the undecorated finished ceiling.
2. Lower Boundaries -- the horizontal plane of the undecorated finished floor.

C. The perimetrical boundaries of the Unit, the Garage and the Storage Room shall be the vertical planes of the undecorated finished interior of the walls bounding the Unit, the Garage or Storage Room extending to intersections with each other and with the upper and lower boundaries. Where there is an aperture in any perimetrical boundary including, but not limited to, windows and doors, the vertical boundary shall be extended at all such places, at right angles, to the dimension of such aperture, so that the perimetrical boundary at such places shall be coincident with the exterior unfinished surface of such aperture, including the framework thereto. Exterior walls made of glass or glass fixed to metal framing, exterior windows and frames, exterior glass sliding doors, frames and casings, shall be included within the Unit and shall not be deemed to be a Common Element.

D. Where a balcony, patio, terrace, loggia, porch, stairway or other portion of the building or any fixture attached to the building serves only the Unit being bounded, the

perimetrical boundary of such Unit shall vary with the exterior unfinished surface of any such structure extended in a vertical plane, where necessary, to the horizontal boundary.

E. Each Unit, the Garage and Storage Room shall not be deemed to include the undecorated and/or unfinished surfaces of the perimeter walls, floors and ceilings surrounding the Unit, the Garage or Storage Room, nor shall a Unit, the Garage or Storage Room be deemed to include pipes, wires, conduits or other public utility lines running through the Unit, the Garage or Storage Room which are utilized for or serve more than one Unit, which items are by these presents hereby made a part of the Common Elements. A Unit, Garage and Storage Room shall be deemed to include the interior walls and partitions which are contained in a Unit, Garage or Storage Room and also shall be deemed to include the inner decorated and/or finished surfaces of the perimeter walls, floors and ceilings of the Unit, Garage or Storage Room, including plaster, paint, wallpaper, etc.

F. There shall pass with each Unit as an appurtenance thereto:

1. An undivided interest in the Common Elements.
2. An undivided share in the Common Surplus.
3. An exclusive easement for the use of the air space occupied by the Unit as it exists at any particular time and as the Unit may lawfully be altered or reconstructed from time to time, which easement shall be terminated automatically in any air space which is vacated from time to time.
4. Such other easements, rights or privileges which, pursuant to the provisions to this Declaration and of law, are deemed appurtenances to the Unit.
5. Membership for the Unit Owner in the Association, with the full voting rights appertaining thereto, subject to the rights and obligations of membership therein.
6. A Garage to be designated by Developer in the deed from Developer conveying a Unit. From and after such conveyance by Developer, the Garage shall be deemed to be appurtenant to the Unit with which it was conveyed by Developer and a subsequent conveyance of such Unit shall effect a conveyance of the appurtenant Garage, regardless of whether the instrument of conveyance recites such Garage. Ownership of a Garage may not be separated from the ownership of the Unit to which it is appurtenant.

G. The Owner of a Unit is entitled to the exclusive possession of the Unit. Each Owner of a Unit shall be entitled to use the Common Elements in accordance with the purposes for which they are intended, but no such use shall hinder or encroach upon the lawful rights of Owners of other Units. There shall be a joint use of the Common Elements and a joint mutual easement for that purpose is hereby created.

H. Each Owner of a Unit shall pay the cost of maintaining all sliding glass doors contained within his Unit, if any, and the replacement or repair of windows and window operators, screening, wiring, electrical outlets and fixtures which are wholly within the Unit.

Rules and regulations regarding the uniform maintenance and appearance of all exterior facing parts of the improvements may be promulgated, from time to time, by the Association.

I. No Unit may be partitioned or subdivided.

J. Each Condominium Unit shall be used only for residential purposes. Each Storage Room shall be used only for storage in connection with the use of a Condominium Unit.

K. The exclusive right to use each Storage Room shall initially be vested by Developer in the Association, or in a Unit Owner selected by Developer, which Unit Owner shall then and thereafter have the right to the exclusive use and possession of such Storage Room, and is herein referred to as the holder of such Storage Room. Thereafter, the holder of a Storage Room may assign the Storage Room to any other Unit Owner who owns a Condominium Unit in the building within which the Storage Room is located. Except as otherwise provided herein, such assignment shall be effected by means of a written instrument signed by the holder of the Storage Room with a copy thereof provided to the Association. Only the Owner of a Unit located in the same building in which the Storage Room is located may be the holder of such Storage Room. The conveyance of a Unit by a Unit Owner shall be deemed to also assign any Storage Room held by such Unit Owner to the grantee of such Unit. Any Storage Room assigned by the Developer to the Association shall remain the property of the Association and shall not be assigned or assignable to any Unit Owner.

#### IV. RESTRAINT UPON SEPARATION AND PARTITION OF COMMON ELEMENTS

A. The undivided share in the Common Elements which is appurtenant to a Unit shall not be separated therefrom and shall pass with the title to the Unit, whether or not separately described.

B. The undivided share in the Common Elements appurtenant to a Unit cannot be conveyed or encumbered except together with the Unit.

C. The undivided share in the Common Elements appurtenant to each Unit shall remain undivided, and no action for partition shall lie.

#### V. COMMON ELEMENTS AND LIMITED COMMON ELEMENTS

Common Elements includes within its meaning the following items:

A. All of the real property, other than the Units and the Limited Common Elements, all of which are as more particularly described and set forth in the Plot Plan, Survey and Graphic Description attached hereto as Exhibit "B". While, as set forth in Articles II(I) and (T) above, Common Elements includes Limited Common Elements, for purposes of location within the Condominium Property, Common Elements shall mean all of the real property, other than the Units and the Limited Common Elements, all of which are more particularly described and set forth in the Plot Plan, Survey and Graphic Description attached hereto as Exhibit "B." Common Elements shall include easements through Units for all conduits, pipes, ducts, plumbing, wiring and all other facilities for the furnishing of utility services to Units and the Common Elements and easements of support in every portion of a Unit which contributes to the support of the

improvements, and shall further include all personal property held and maintained for the joint use and enjoyment of the Unit Owners.

B. Installations for the furnishing of utility services to more than one Unit or to the Common Elements, Limited Common Elements, or to a Unit other than the Unit containing the installation.

C. Easements for encroachments by the perimeter walls, ceilings, and floors surrounding each Unit caused by minor inaccuracies in building or rebuilding which now exist or hereafter exist, and such easements shall continue until such encroachment no longer exists.

D. Easements for overhanging troughs and gutters, downspouts, and the discharge therefrom of rain water and the subsequent flow thereof over Units.

E. A non-exclusive easement for ingress and egress over the walks and other rights-of-way of the Common Elements as shall be necessary to provide access to the public ways to and from the Units.

F. All Limited Common Elements not otherwise assigned by the Developer as provided herein.

G. The Board of Directors may, from time to time, at its sole discretion, assign not more than one (1) outside parking space to each Unit. The parking space assigned to a Unit shall be located in the area near the building in which the Unit is located, but need not be the closest or most convenient space to the Unit. The Board of Directors shall not assign a parking space to a Unit unless it also assigns parking spaces to all other Units located in the same Building.

## VI. CONDOMINIUM PROPERTY AND IDENTIFICATION OF UNITS

Annexed hereto as Exhibit "B" is a survey of the real property being submitted to the condominium form of ownership, together with a plot plan and graphic description of the improvements in which the Units are located. The identification, location and dimensions of each Unit and the Common Elements appear on the aforescribed Exhibit "B". Each Unit has been given a designation for purposes of identification so that no Unit has the same designation as any other Unit.

## VII. OWNERSHIP OF COMMON ELEMENTS AND SHARES OF COMMON SURPLUS

The Owner of each Unit shall own a share and an interest in the Condominium Property which is appurtenant to the Unit Owner's Unit which includes, but is not limited to, the following items:

A. Common Elements -- The undivided shares, based on a fractional basis in the Common Elements appurtenant to each of the Units as set forth on the schedule attached hereto and made a part hereof by reference as Exhibit "C"; and

B. Common Surplus -- Any Common Surplus of the Association, in the same percentage as the Common Elements appurtenant to each Unit are owned, as set forth in Exhibit

"C". This ownership, however, does not include the right to withdraw or require payment or distribution of said Common Surplus.

### VIII. AMENDMENT TO DECLARATION

A. Except as herein or otherwise provided, this Declaration may be amended in the following manner:

1. Notice of the subject matter of a proposed amendment shall be included in the notice of any meeting at which a proposed amendment is to be considered.

2. An amendment may be proposed by either a majority vote of the Board of Directors of the Association, or by the vote of not less than 51% of the members of the Association present, either in person or by proxy, at a duly called meeting of the members of the Association. Directors and members not present in person or by proxy at the meeting considering the amendment may express their approval or disapproval in writing, provided such approval or disapproval is delivered to the Secretary at or prior to the meeting. Except as elsewhere provided, a resolution adopting the proposed amendment must be approved by either:

a. The vote of not less than 66-2/3 % of the Board of Directors and the vote of not less than 66-2/3 % of the members of the Association present, either in person or by proxy, at a duly called meeting of the members of the Association; or

b. The vote of not less than 80% of the members of the Association present, either in person or by proxy, at a duly called meeting of the members of the Association.

B. No amendment shall change the configuration of any Unit nor a Unit's proportionate share of the Common Elements, the Common Expenses or Common Surplus, nor the voting rights appurtenant to any Unit, unless the amendment is approved by: (i) not less than 51 % of the total votes of the Association; (ii) the record Owner(s) of the Unit(s) affected by such amendment; and (iii) the record Owner(s) of all liens encumbering the Unit(s) affected by such amendment.

C. Notwithstanding anything to the contrary herein, the Developer reserves the right to amend this Declaration and its Exhibits to conform to Florida Statutes Chapter 718, to increase or add to any recreational facilities, to add additional phases, to modify the provisions relating to any additional phase until the same has been added, to clarify ambiguities, to correct any omissions or errors (including scrivener's or surveyor's errors), and to make any other amendment which would not be prohibited by the Act, so long as such amendments do not materially and adversely affect the rights of Unit Owners or mortgagees. Such amendment need be executed and acknowledged by the Developer only.

In addition, the Developer reserves the right to amend this Declaration pursuant to the provisions of Article XXVI herein, provided said amendment(s) is in accordance with the Act.

D. In the event it shall appear that there is an error or omission in this Declaration or in the Exhibits attached hereto, then and in that event, the Association may correct such error and/or omission by amendment to this Declaration in the following manner:

1. Notice of the subject matter of a proposed amendment to cure a defect, error or omission shall be included in the notice of any meeting at which such amendment is to be considered;

2. A resolution for the adoption of such a proposed amendment may be proposed by either the Board of Directors of the Association or by the members of the Association, and members of the Association not present in person or by proxy at the meeting considering the amendment may express their approval or disapproval by writing delivered to the Secretary at or prior to the meeting considering adoption of the amendment. Such approvals to amend this Declaration must be either by:

a. The vote of not less than 66-2/3 % of the Board of Directors and the vote of not less than 33-1/3% of the members of the Association present, either in person or by proxy, at a duly called meeting of the members of the Association; or

b. The vote of not less than a majority of the members of the Association present, either in person or by proxy, at a duly called meeting of the members of the Association; or

c. In the alternative, an amendment may be made by an agreement signed and acknowledged by all Unit Owners in the manner required for the execution of a deed, and such amendment shall be effective when recorded in the Public Records of St. Johns County, Florida.

E. No provision of this Declaration shall be revised or amended by reference to its title number only. Proposals to amend existing provisions of this Declaration shall contain the full text of the new provision to be amended; old words shall be lined through with hyphens, and new words shall be underlined. However, if the proposed change is so extensive that this procedure would hinder, rather than assist, the understanding of the proposed amendment, it is not necessary to use underlining and hyphens as indicators of words added or deleted but, instead, a notation must be inserted immediately preceding the proposed amendment in substantially the following language: "Substantial rewording of Declaration. See provision \_\_\_\_\_ for present text." Non-material errors or omissions in the amendment process shall not invalidate an otherwise properly promulgated amendment.

F. Except as may be otherwise provided in this Declaration, a copy of each amendment shall be attached to a certificate, certifying that the amendment was duly adopted. Each amendment shall be effective when the certificate and copy of the amendment are recorded in the Public Records of St. Johns County, Florida.

#### IX. THE ASSOCIATION: ITS POWERS AND RESPONSIBILITIES

A. The Condominium is governed and administered by Ocean Grande Condominium Association, Inc., a Florida not-for-profit corporation. A copy of the Articles of Incorporation of the Association is annexed hereto and made a part hereof as Exhibit "D". Amendments to the Articles of Incorporation shall be valid when adopted in accordance with its provisions and the provisions of the By-Laws and filed with the Secretary of State or as otherwise required by Chapter 617, Florida Statutes, as same may be amended from time to time. No amendment to

the Articles of Incorporation shall be valid unless recorded with identification on the first page thereof of the official records book and page number of the public records of the county in which this declaration is recorded. No amendment to the Articles of Incorporation shall, however, change the size of any Unit nor the share of Common Elements, Common Expenses or Common Surplus appurtenant to a Unit nor the voting rights appurtenant to a Unit unless the record Owner or Owners thereof and all record owners of mortgages encumbering such Unit or Units shall join in the execution of such amendment and such amendment is approved by not less than a majority of the total votes of the Association.

B. The powers and duties of the Association shall include those set forth in the By-Laws annexed hereto and made a part hereof as Exhibit "E" but, in addition thereto, the Association shall have all of the powers and duties set forth in the Act, as well as all of the powers and duties granted to or imposed upon it by this Declaration, including:

1. The irrevocable right to have access to each Unit from time to time during reasonable hours as may be necessary for the maintenance, repair or replacement of any Common Elements, Limited Common Elements, or of any portion of a Unit to be maintained by the Association or as may be necessary to prevent damage to the Common Elements, Limited Common Elements, or to a Unit or Units. In this regard, the Association may retain a pass-key to all Units. In the event the Unit Owner fails to supply a pass-key to the Association and, pursuant to the terms of this Declaration, entry into the Unit by the Association is permitted, the Association shall not be responsible for any damage which may arise as the result of a forced entry into the Unit.

2. The power to make and collect Assessments, regular and special, and to lease, maintain, repair and replace the Common Elements.

3. The duty to maintain accounting records prepared according to generally accepted accounting practices, which records shall be open to inspection by Unit Owners at reasonable times during normal business hours.

4. The power to enter into contracts with others for a valuable consideration, for maintenance and management, including the normal maintenance and repair of the Common Elements. The duty and responsibility to maintain and preserve the landscaping, gardening, painting, repairing and replacement of the Common Elements shall not relieve the Unit Owner of Unit Owner's personal responsibility to maintain and preserve the interior of his Unit and the Limited Common Elements appurtenant thereto, and to paint, clean, decorate, maintain and repair his Unit.

5. The power to adopt reasonable rules and regulations for the maintenance and conservation of the Condominium Property and for the health, comfort, safety and welfare of the Unit Owners.

C. The By-Laws may be amended in the manner provided for therein, but no amendment to the By-Laws shall be adopted which would affect or impair the validity or priority of any Institutional Mortgage encumbering any Unit(s), or which would change the provisions of



the By-Laws with respect to the rights of Institutional Mortgagees, without the written approval of all Institutional Mortgagees, of record.

D. Each Unit shall be entitled to one vote to be cast in accordance with the provisions of the Articles of Incorporation and the By-Laws of the Association.

E. The Association or its designees shall maintain such records as are required by Section 718.111, Florida Statutes.

F. In any legal action in which the Association may be exposed to liability in excess of insurance coverage protecting it and the Unit Owners, the Association shall give notice of the exposure within a reasonable time to all Unit Owners and to all Institutional Mortgagees who may be exposed to the liability, so that such Unit Owners and/or such Institutional Mortgagees shall have the right to intervene and defend.

#### X. MAINTENANCE, ALTERATIONS AND IMPROVEMENTS

The responsibility for the maintenance of the Condominium Property and restrictions upon its alteration and improvement shall be as follows:

A. By the Association -- The Association shall maintain, repair and replace at the Association's expense:

1. All Common Elements.
2. All portions of the Units (except interior wall surfaces) contributing to the support of the building, which portions shall include, but not be limited to, the outside walls of the building and load-bearing columns.
3. All conduits, ducts, plumbing, wiring and other facilities for the furnishing of utility services contained within a Unit which service part or parts of the Condominium other than the Unit within which contained.
4. All parking areas of the Condominium.
5. All property owned by the Association.

Subject to the provisions of Article IX, Subparagraph B.1 of this Declaration, all incidental damage caused to a Unit by such work shall be promptly repaired at the expense of the Association.

B. By the Unit Owner. The responsibilities of each Unit Owner shall be as follows:

1. To maintain, repair and replace, at the Unit Owner's expense, all portions of the Unit, the appurtenant Garage, and any Storage Room owned by such Unit Owner except the portions to be maintained, repaired and replaced by the Association. Included within the responsibility of the Unit Owner shall be the responsibility to maintain, repair and replace all plate glass, sliding glass doors, windows, screens and doors opening into or onto the Unit,

Garage or Storage Room. All such maintenance, repairs and replacements shall be done without disturbing the rights of other Unit Owners.

2. To maintain, repair and replace at Unit Owner's expense, Unit Owner's individual air-conditioning and heating system located inside and outside of the Unit Owner's individual Unit.

3. Within the Unit, to maintain, repair and replace at Unit Owner's expense all fans, stoves, refrigerators, dishwashers, washing machines, dryers, or other appliances or equipment, including all fixtures and/or their connections required to provide water, light, power, telephone, sewage and sanitary service to Unit Owner's Unit. The floor, railings and interior walls of any balcony, terrace or patio of a Unit shall be maintained by the Unit Owner at such Unit Owner's expense.

4. Within and without the Unit, Garage and any Storage Room, not to paint or otherwise decorate or change the appearance of any exterior portion of the building, including balconies, patios or terraces, or any stucco portion of the Condominium.

5. To promptly report to the Association any defects or need for repairs, the responsibility for the remedy of which is that of the Association.

6. No Unit Owner, other than the Developer, shall make any alterations in the portions of the Condominium which are to be maintained by the Association, or remove any portion thereof or make any additions thereto or do any work which would jeopardize the safety or soundness of the building or impair any easement, without first obtaining approval from the Board of Directors of the Association.

7. Any Unit Owner performing any repairs or maintenance shall be liable to the Association for any damage to Common Elements and Limited Common Elements caused by or in the course of performance of such repairs and maintenance.

C. Alteration of Unit. No Owner of a Unit shall make or cause to be made any structural modifications or alterations or replacements in Unit Owner's Unit, Garage or Storage Room, or in the exterior doors of Unit Owner's Unit, Garage or Storage Room, or in the water, gas, electrical, plumbing, air-conditioning equipment or utilities therein, without the consent of the Board of Directors of the Association, which consent may be withheld in the event the Board of Directors determines that such structural alteration, modification or replacement would in any manner endanger the structural soundness of the building or the utility service to any other Unit. If the modification, alteration or replacement desired by an Owner of a Unit involves the removal of any interior partition, the Board of Directors may permit same if the same is not a load-bearing partition and if the same does not interfere with any common utility source. A Unit Owner making or causing to be made any structural modification, alteration or replacement to the Unit Owner's Unit, Garage or Storage Room agrees, and shall be deemed to have agreed, to hold the Association and all other Unit Owners harmless from any liability arising therefrom. No Unit Owner shall cause any improvements or changes to be made to the exterior of the Condominium including, but not limited to, painting, installation of electrical wires, television antennae, satellite dishes, or air conditioning units which may protrude through the walls or roof

of the building, or in any manner change the appearance of the exterior of the building or any portion of the building not totally within each Unit, without consent of the Board of Directors. No Unit Owner, other than the Developer and/or the agents of the Developer, or any other person shall install upon the roof or exterior of the building or upon the Common Elements of the Condominium, any television antennae, radio antennae, satellite dish, electric, electronic, electro-mechanical or other communications device, decorative item or affixed furnishing, without the consent of the Board of Directors.

D. Liability of Unit Owner. Should a Unit Owner undertake unauthorized additions and modifications to the Unit Owner's Unit, Garage or Storage Room, or refuse to make repairs as required, or should a Unit Owner cause damage to the Condominium Property, the Association shall have the right to avail itself of the remedies set forth in Section 718.303(1) and (3), Florida Statutes, which remedies include the levy of a reasonable fine, an action for damages or an action for injunctive relief.

E. Insurance Proceeds. Whenever any maintenance, replacement and repair of any items for which the Owner of a Unit is responsible is made necessary by any loss covered by insurance maintained by the Association, the proceeds of the insurance received by the Association, or by the Insurance Trustee, shall be used for the purpose of accomplishing such maintenance, repair or replacement. The Unit Owner shall be required to pay all of the costs thereof that exceed the amount of the insurance proceeds.

#### XI. ENFORCEMENT OF MAINTENANCE

In the event the Owner of a Unit fails to maintain the Unit and the appurtenances thereto, as required above, the Association, the Developer, or any other Unit Owner shall have the right to proceed in a court of equity to seek compliance with the foregoing provisions.

Further, in the event a Unit Owner violates any of the provisions of Article X above, the Developer and/or the Association shall have the right to take any and all such lawful steps as may be necessary to remedy such violation.

#### XII. COMMON EXPENSES

A. Common Expenses shall include expenses of the operation, maintenance, repair or replacement of the Common Elements (and those portions of the Limited Common Elements to be maintained by the Association), costs of carrying out the powers and duties of the Association, and any other expenses designated from time to time as Common Expenses by the Association.

B. All costs of electricity, water, gas, trash and garbage collection and sewage service for the Condominium other than such services which are provided to individual Units.

C. Common Expenses shall be shared by each Unit in accordance with each Unit's respective interests in the Common Elements and in the Common Surplus, as set forth in Exhibit "C". The foregoing ratio of sharing Common Expenses and Assessments shall remain, regardless of the purchase price of the Units or their locations.

XIII. ASSESSMENTS; LIABILITY, LIEN AND PRIORITY; INTEREST; COLLECTION

A. The Association, through its Board of Directors, shall have the power to fix and determine from time to time, a budget necessary to provide for the Common Expenses of the Condominium. A Unit Owner, regardless of how title is acquired, except as provided in Article XIV below, shall be personally liable for all Assessments coming due while such Unit Owner is the Owner of a Unit. In a voluntary conveyance, the grantee shall be jointly and severally liable with the grantor for all unpaid Assessments against the Unit being conveyed.

B. The Board of Directors shall adopt a Budget for the Association during the month preceding the fiscal year in which the Budget will take effect, which Budget shall include a schedule of Assessments to be paid by the Unit Owners.

C. Each Unit Owner shall be responsible for the payment of the Assessments imposed against the Unit Owner's Unit in an amount equal to the percentage of responsibility for payment of Common Expenses set forth in Exhibit "C" attached hereto.

D. Regular Assessments shall be paid by the Unit Owners on a monthly basis payable on the first day of each and every month.

E. Should the Association, through its Board of Directors, at any time determine that the Assessments made are not sufficient to pay the Common Expenses and in the event of emergencies, the Board of Directors shall have the authority to levy and collect additional and/or special Assessments to meet such needs of the Association.

F. The Board of Directors of the Association, in assessing for Common Expenses, shall (unless waived or reduced pursuant to applicable law) include therein a sum to be collected and maintained as a reserve fund for capital expenditures and deferred maintenance. These accounts shall include, but are not limited to, roof replacement, building painting and pavement resurfacing, regardless of the amount of deferred maintenance expense or replacement cost, and for any other item for which the deferred maintenance expense or replacement cost exceeds, or is anticipated to exceed \$10,000.00. All reserve funds, and any interest accruing thereon, shall remain in the reserve account or accounts and shall be used only for authorized reserve expenditures, unless the use of reserve funds for other purposes is approved in advance by a majority vote of Unit Owners at a duly called meeting of the Association.

G. The Board of Directors of the Association, in assessing for Common Expenses, may include therein a sum to be collected and maintained as a general operating reserve which shall be used to provide a measure of financial security during periods of stress. Such sums may be used to meet deficiencies from time to time existing as a result of delinquent payment of Assessments by Unit Owners or as a result of emergencies.

H. All monies collected by the Association from Assessments imposed against Unit Owners in this Condominium shall, unless the same is collected for the benefit of others, be the separate property of the Association. Such monies may be applied by the Association to the payment of any expense of operating and managing the Condominium Property, or to the proper undertaking of all acts and duties imposed upon it by virtue of the provisions of this Declaration. All monies received from Assessments imposed against Unit Owners in this Condominium shall

be maintained separately in the name of the Association. Reserve and operating funds of the Association shall not be commingled unless combined for investment purposes. However, such funds must be accounted for separately, and the combined account balance may not, at any time, be less than the amount identified as reserve funds in the combined accounts. All monies received by the Association from Assessments imposed against Unit Owners in this Condominium shall be held for the benefit of the Unit Owners in this Condominium and may not be expended for the benefit of any other condominium. No Unit Owner shall have the right to assign, hypothecate, pledge or in any manner transfer his interest therein, except as an appurtenance to his Unit. Such funds shall not be subject to attachment or levy by a creditor or judgment creditor of a Unit Owner. When the Owner of a Unit shall cease to be a member of the Association, by the divestment of his ownership of such Unit by whatever means, the Association shall not be required to account to such Owner for any share of the funds or assets of the Association.

I. Liability for Assessments may not be avoided by abandonment of a Unit, or by waiver of the use of any Common Elements or other property which a Unit Owner is entitled to use or enjoy.

J. Assessments not paid within five (5) days of the date when due shall bear interest from the date when due until paid at the rate of eighteen percent (18 %) per annum. Additionally, the failure to pay any Assessment within five (5) days from the date due shall entitle the Association to levy an administrative late fee, in addition to interest upon the delinquent Assessment, in an amount not to exceed the greater of \$25.00 or five percent (5.00%) of each installment of the delinquent Assessment. Payments made shall be applied to interest and administrative late fees first and then to the delinquent Assessment. The Association shall furnish to any Institutional Mortgagee, upon its request, written notification of any default in Assessment payments of the Unit Owner whose Unit is encumbered by the Institutional Mortgage.

K. The Association is hereby granted a lien on each Unit, which lien shall secure the payment of all Assessments, interest thereon, administrative late fees, and reasonable costs and attorneys' fees incurred as an incident to the enforcement of said lien. Notwithstanding anything to the contrary which may be contained herein, no fine shall become a lien against a Unit. The lien shall be effective, have priority and be collected as provided by the Act.

L. Liens for Assessments may be foreclosed by suit brought in the name of the Association in like manner as a foreclosure of a mortgage on real property, as more fully set forth in the Act. The Association may bid at any sale and apply as a cash credit against its bid all sums due the Association covered by the lien being enforced. In any suit for the foreclosure of said lien, the Association, provided the Unit Owner has remained in possession of the Unit, shall be entitled to petition a court of competent jurisdiction for payment of a reasonable rental from the Owner of such Unit from the date on which the payment of any Assessment or installment thereof became delinquent, and shall be entitled to the appointment of a receiver for said Unit.

M. The liability of a first mortgagee or its successors or assignees who acquire title to a Unit by foreclosure or by deed in lieu of foreclosure for the unpaid Assessments that became due prior to the mortgagee's acquisition of title is limited to the lesser of:

1. The Unit's unpaid Common Expenses and regular periodic Assessments which accrued or came due during the six (6) months immediately preceding the acquisition of title and for which payment in full has not yet been received by the Association; or

2. One percent (1 %) of the original mortgage debt.

The provisions of this paragraph shall not apply unless the first mortgagee joined the Association as a defendant in the foreclosure action. Joinder of the Association is not required if, on the date the complaint is filed, the Association was dissolved or did not maintain an office or agent for service of process at a location which was known to or reasonably discoverable by the mortgagee.

**XIV. MAINTENANCE GUARANTEE**

During the period commencing from the date of recording of the first deed of conveyance to the purchaser of a Unit until the earlier of (i) two (2) years thereafter, or (ii) the date on which control of the Board of Directors of the Association is turned over to Unit Owners other than the Developer (the "Initial Guarantee Expiration Date"), the Developer shall not be obligated to pay the share of the Common Expenses and Assessments attributable to Units that it owns, provided that the regular monthly Assessments for Common Expenses imposed on each Unit Owner other than the Developer shall not increase during such periods over the following amounts for each of the following units, which amount may be increased by not more than 5% per annum:

<u>UNIT NO.</u>	<u>MONTHLY ASSESSMENT</u>
Building 1, Units 102, 105, 202, 205, 302, 305 Building 3, Units 102, 105, 202, 205, 302, 305	\$406.27
Building 1, Units 103, 104, 203, 204, 303, 304 Building 2, Units 102, 103, 202, 203, 302, 303 Building 3, Units 103, 104, 203, 204, 303, 304 Building 4, Units 102, 103, 202, 203, 302, 303	\$406.48
Building 1, Units 101, 106, 201, 206, 301, 306 Building 2, Units 101, 104, 201, 204, 301, 304 Building 3, Units 101, 106, 201, 206, 301, 306 Building 4, Units 101, 104, 201, 204, 301, 304	\$447.00

and provided further that the Developer shall be obligated to pay any amount of Common Expenses actually incurred during such periods and not produced by the Assessments at the guaranteed level. For purposes of this paragraph, income to the Association other than Assessments (as defined herein and in the Act) shall not be taken into account when determining the deficits to be funded by the Developer. After the Initial Guarantee Expiration Date, the Developer shall have the option of extending the guarantee for one (1) or more additional periods, (not to exceed eight (8) additional periods) of one (1) year each (an "Additional Guarantee Period") as provided in Florida Statutes, Section 718.116(9). During an Additional Guarantee Period, if any, the Developer guarantees that regular monthly Assessments for Common Expenses imposed on each Unit Owner other than the Developer shall not increase

during any such Additional Guarantee Period over the amounts set forth above. Furthermore, during an Additional Guarantee Period, if any, the Developer shall be obligated to pay any amount of Common Expenses actually incurred during an Additional Guarantee Period not produced by the Assessments at the guaranteed level. The Developer shall be deemed to have automatically extended the guarantee, by an Additional Guarantee Period, unless the Developer notifies the Board of Directors of Ocean Grande Condominium Association, Inc., in writing, of its election not to extend the guarantee for an Additional Guarantee Period. The Developer may also further extend the guarantee for a definite period of time by written agreement with a majority of non-Developer Unit Owners. No funds received from Unit Owners payable to the Association or collected by the Developer on behalf of the Association, other than regular periodic Assessments for Common Expenses as provided in this Declaration and disclosed in the Estimated Operating Budget referred to above, shall be used for the payment of Common Expenses prior to the Guarantee Expiration Date. This restriction shall apply to funds including, but not limited to, capital contributions or start-up funds collected from Unit Owners at closing. Notwithstanding the foregoing, if the Developer-controlled Association has maintained all insurance coverages required by '718.111(11)(a), Florida Statutes, the common expenses incurred during the Guarantee Period or any Additional Guarantee Period resulting from a natural disaster or an act of God, which are not covered by insurance proceeds from the insurance maintained by the Association, may be assessed against all unit owners owning units on the date of such natural disaster or act of God, and their successors and assigns, including the Developer with respect to Units owned by the Developer. In the event of such assessment, all Units shall be assessed in accordance with their ownership interest in the Common Elements as set forth on Exhibit "C" to the Declaration.

#### XV. LIMITATION OF LIABILITY

A. The liability of the Owner of a Unit for Common Expenses shall be limited to the amounts for which such Unit Owner is assessed from time to time in accordance with this Declaration and the By-Laws (including any interest, penalties, costs or fees provided for therein in the event of delinquency).

B. To the extent that the Owner of a Unit may be personally liable under applicable law for acts or omissions of the Association in relation to the use of the Common Elements, such liability shall be limited to such Unit Owner's pro rata share of that liability in the same percentage as such Unit Owner's interest in the Common Elements, and in no event shall such liability exceed the value of the Unit Owner's Unit.

#### XVI. LIENS

A. Unless a Unit Owner has expressly requested or consented to work being performed or materials being furnished to such Unit Owner's Unit, such furnishing of labor or materials may not be the basis for the filing of a mechanic's lien against the Unit Owner's Unit. No labor performed or materials furnished to the Common Elements shall be the basis for the filing of a lien thereon unless authorized by the Association, in which event same may be the basis for the filing of a lien against all Units in the proportions for which the Units are liable for Common Expenses.

B. In the event a lien against two or more Units becomes effective, each Unit Owner thereof may relieve his Unit of the lien by paying the proportionate amount attributable to the Unit Owner's Unit. Upon such payment, it shall be the duty of the lienor to release the lien of record against such Unit.

## XVII. EASEMENTS

Each of the following easements is hereby created as a covenant running with the land of the Condominium, to-wit:

A. Utility Services; Drainage. Easements are reserved under, through, across and over the Condominium Property as may be required for utility services, cable television service, and drainage in order to serve the Condominium. A Unit Owner shall do nothing within or outside such Unit Owner's Unit that interferes with or impairs the utility services and cable television services using these easements. The Association or its designee shall have a right of access to each Unit to maintain, repair or replace the telephone wiring, telephone lines, pipes, wires, ducts, vents, cables, conduits and other utility or other service facilities and Common Elements contained in the Unit or elsewhere in the Condominium Property, and to remove any improvements interfering with or impairing the utility services or easements herein reserved; provided that such right of access shall not unreasonably interfere with the Unit Owner's permitted use of the Unit, and entry shall be made on not less than one day's notice, except in the event of an emergency.

B. Traffic. An easement shall exist for pedestrian traffic over, through and across all sidewalks, driveways, paths, walks, halls, lobbies, elevators, center cores, and other portions of the Common Elements as may be intended and designated from time to time for such purpose and use; and for vehicular and pedestrian traffic over, through and across such portions of the Common Elements and Limited Common Elements as may, from time to time, be paved and intended for such purpose; and such easements shall be for the use and benefit of Unit Owners, lessees, Institutional Mortgagees, and those claiming by, through or under the aforesaid.

C. Easement for Unintentional and Non-Negligent Encroachments. If a Unit shall encroach upon any Common Element, Limited Common Element or upon any other Unit, by reason of original construction or by reason of the non-negligent or non-purposeful act of the Developer, then an easement appurtenant to such encroaching Unit, to the extent of such encroachment, shall exist so long as such encroachment shall exist.

D. Support. The Developer and the Association hereby grant to each other and to their respective heirs, successors, and assigns, and to all third party beneficiaries, including Unit Owners, lessees, guests, invitees, servants and employees, the right of support for all structures on any portion of the real property of the Condominium.

E. Additional Easements. The Association has the right to grant to owners and users of property which is contiguous to the Condominium Property, easements upon, under, over and across the Common Elements of the Condominium for purposes of use, ingress, egress and access. In addition, the Association shall have the right to grant such additional electric, cable television, telephone, gas or other utility easements, and to relocate any existing easements in



any portion of the Condominium Property, and to grant access easements and relocate any existing access easements in any portion of the Condominium Property, as the Association shall deem necessary or desirable for the proper operation and maintenance of the improvements, or any portion thereof, or for the general health or welfare of the Unit Owners, or for the purpose of carrying out any provisions of this Declaration; provided that such easements or the relocation of existing easements will not prevent or unreasonably interfere with the use of the Units for their intended purposes.

F. Developer Easement. Each Unit Owner acknowledges that Developer is constructing the Condominium Property. In that regard, it may be necessary for the Developer to enter a Unit after closing. Each Unit Owner agrees that Developer may enter the Unit to make or complete any renovations to the Unit which may be necessary, or the Developer may enter the Unit to complete repairs or renovations to any other part of the Condominium Property the completion of which may require the Developer and its agents to gain access to the Unit. The easement granted to the Developer hereby shall remain in effect so long as the Developer owns at least one (1) Unit in the Condominium. The provisions contained in this Article XVII(G) may not be amended, modified or deleted, in whole or in part, without the written consent of the Developer.

G. Covenants Running with the Land. Except as may be otherwise provided herein, all easements, of whatever kind or character, whether heretofore or hereafter created, shall constitute covenants running with the land, and, notwithstanding any other provisions of this Declaration, may not be substantially amended or revoked in a way which would unreasonably interfere with the proper and intended use and purpose of any such easement. The Unit Owners do hereby designate the Association as their lawful attorney-in-fact, coupled with an interest, to execute any and all instruments on their behalf for the purpose of creating all such easements as are contemplated by the provisions hereof.

#### XVIII. OBLIGATIONS OF UNIT OWNERS

In addition to the other obligations and duties heretofore set out in this Declaration, each Unit Owner shall:

- A. Promptly pay all Assessments, regular and special, levied by the Association.
- B. Maintain in good condition and repair such Unit Owner's Unit, Garage and Storage Room, and maintain and repair the fixtures therein and pay for any utilities which are separately metered to such Unit Owner's Unit.
- C. Not permit or suffer anything to be done or kept in such Unit Owner's Unit, Garage or Storage Room which will increase the insurance rates on such Unit Owner's Unit, or the Common Elements, or which will unreasonably obstruct or interfere with the rights of other Unit Owners or annoy them by noises or otherwise; nor shall a Unit Owner commit or permit any nuisance or any immoral or illegal act in such Unit Owner's Unit or on the Common Elements.

D. Conform to and abide by the By-Laws and such rules and regulations which may be adopted in writing, from time to time, by the Board of Directors of the Association and see that all persons using such Unit Owner's Unit by, through or under the Unit Owner do likewise.

E. Make no alteration, decoration, repair, replacement or change to the Common Elements or to any outside or exterior portion of the Condominium, except as set forth herein.

F. Exhibit no sign, advertisement or notice of any type on the Common Elements or on such Unit Owner's Unit, Garage or Storage Room except as may be approved by the Association. The prohibitions contained in this subparagraph shall not be applicable to the Developer and/or to agents of the Developer.

G. Make no repairs to any plumbing or electrical wiring, except within a Unit. Plumbing and electrical repairs within a Unit shall be the financial obligation of the Owner of the Unit and shall be paid for forthwith.

H. Return the "Unit" for the purpose of ad valorem taxes to the respective taxing authorities having jurisdiction over them for separate assessment against Unit Owner's Unit. For the purposes of ad valorem taxation, the interest of the Unit Owner in such Unit Owner's Unit and Common Elements appurtenant thereto shall be considered as a Unit.

#### XIX. INSURANCE

A. Liability Insurance. The Board of Directors of the Association shall utilize due diligence to obtain public liability insurance, directors' and officers' liability insurance and property damage insurance covering all real property owned by the Association and all of the Common Elements of the Condominium (not including floor coverings, wall coverings and ceiling coverings), and insuring the Association, all Unit Owners and all Institutional Mortgagees, as it and their interests may appear, in such amounts as the Board of Directors may determine from time to time, provided that the minimum amount of coverage shall, to the extent such coverage is available, be at least \$1,000,000.00 per occurrence combined single limit bodily injury and property damage. Said insurance coverage shall include, but not be limited to, water damage, legal liability, hired automobile, non-owned automobile and all premises and operations. All liability insurance shall contain a cross-liability endorsement to cover the liability of all the Unit Owners, as a group, to any one Unit Owner. Premiums for the payment of such insurance shall be paid by the Association and charged as a Common Expense.

B. Casualty Insurance - Purchase of Insurance. The Association shall obtain "all risk" insurance, flood insurance (if available) and vandalism and malicious mischief insurance, insuring all of the insurable improvements within the Condominium (except for floor coverings, wall coverings and/or ceiling coverings), including personal property owned by the Association, in and for the interest of the Association, all Unit Owners and Institutional Mortgagees, as their interests may appear, with a company acceptable to the Board of Directors of the Association, in an amount equal to the maximum insurable replacement value, as determined annually. The premiums for such coverage and other expenses in connection with said insurance placement shall be paid by the Association and charged as a Common Expense. The company or companies with whom the Association shall place its insurance coverage, as provided in this

Declaration, must be good and responsible companies, authorized to do business in the State of Florida.

C. Loss Payable Provisions -- Insurance Trustee. All policies purchased by the Association shall be for the benefit of the Association, all Unit Owners and their mortgagees, as their interests may appear. Said policies shall provide that all insurance proceeds payable on account of loss or damage shall be payable to a banking institution having trust powers and doing business in the State of Florida selected by the Board of Directors of the Association (the "Insurance Trustee"). The Insurance Trustee shall not be liable for the payment of premiums, nor for the renewal or the sufficiency of policies, nor for the failure to collect any insurance proceeds, nor for the form or content of the policies. The sole duty of the Insurance Trustee shall be to receive such proceeds as are paid and to hold the same in trust for the purposes elsewhere stated herein, and for the benefit of the Association, the Unit Owners and their respective mortgagees (sometimes hereinafter collectively referred to as the "beneficial owners"), in the following shares, but such shares need not be set forth upon the records of the Insurance Trustee:

1. Common Elements. Proceeds on account of damage to Common Elements shall be an undivided share for each Unit Owner, such share being the same as the undivided share in the Common Elements appurtenant to such Unit Owner's Unit.

2. Units. Proceeds on account of Units shall be in the following undivided shares:

a. Partial destruction, when Units are to be repaired and restored for the Owners of the damaged Units, in proportion to the cost of repairing the damage suffered by each Unit Owner.

b. Total destruction of Condominium improvements, or where "very substantial" damage occurs and the Condominium improvements are not to be restored, as provided hereafter in this Article, for the Owners of all Units, each Unit Owner's share being in proportion to the damage suffered by the Unit Owner as a result of the casualty.

3. Mortgagees. In the event an Institutional Mortgage encumbers a Unit, the share of the Unit Owner shall be held in trust for the particular Institutional Mortgagee and the Unit Owner, as their interests may appear; provided, however, that no mortgagee shall have any right to determine or participate in the determination as to whether or not any damaged property shall be reconstructed or repaired.

D. Distribution of Proceeds. Proceeds of insurance policies received by the Insurance Trustee shall be distributed to or for the benefit of the beneficial owners and expended or disbursed after first paying or making provision for the payment of the expenses of the Insurance Trustee, in the following manner:

1. Reconstruction or Repair. If the damage for which the proceeds were paid is to be repaired and restored, the remaining proceeds shall be paid to defray the cost thereof, as elsewhere provided. Any proceeds remaining after defraying such costs shall be distributed to the beneficial owners, all remittances to Unit Owners and their mortgagees being payable jointly

to them. This is a covenant for the benefit of any mortgagee of a Unit and may be enforced by any mortgagee.

2. Failure to Reconstruct or Repair. If the damage for which the proceeds were paid shall not be repaired and restored, any proceeds remaining after defraying such costs shall be distributed to the beneficial owners, all remittances to Unit Owners and their mortgagees being payable jointly to them. This is a covenant for the benefit of any mortgagee of a Unit and may be enforced by any mortgagee. In the event of the loss or damage to personal property belonging to the Association, and should the Board of Directors of the Association determine not to replace such personal property as may be lost or damaged, the proceeds shall be disbursed to the beneficial owners as surplus in the manner elsewhere stated.

3. Certificate. In making distribution to Unit Owners and their mortgagees, the Insurance Trustee may rely upon a certificate of the Association, executed by the President (or Vice-President) and Secretary of the Association, as to the names of the Unit Owners and their respective shares of distribution. Upon request of the Insurance Trustee, the Association forthwith shall deliver such certificate. In addition, the Insurance Trustee may rely on such certificate as to whether or not the damaged property is to be repaired and restored and as to the payee and the amount to be paid from said proceeds.

E. Loss Within a Single Unit. If loss shall occur within a single Unit or Units, without damage to the Common Elements, the insurance proceeds shall be distributed to the affected Unit Owner(s), remittance by the Insurance Trustee to Unit Owners and their mortgagees being payable jointly to them. This is a covenant for the benefit of any mortgagee of a Unit and may be enforced by any mortgagee. The Unit Owner shall thereupon be fully responsible for the restoration of the Unit and shall restore the Unit within a reasonable time.

F. Loss Less Than "Very Substantial". Where a loss or damage occurs to more than one Unit and/or to the Common Elements, or to any Unit or Units and the Common Elements, but said loss is less than "very substantial" (as hereinafter defined), it shall be obligatory upon the Association and the Unit Owners to repair, restore and rebuild the damage caused by said loss. Where such loss or damage is less than "very substantial":

1. The Board of Directors of the Association shall promptly obtain reliable and detailed estimates of the cost of repairing and restoration.

2. If the damage or loss is limited to the Common Elements, with minimum or no damage or loss to any individual Unit, and if such damage or loss to the Common Elements is less than \$10,000.00, the insurance proceeds shall be endorsed by the Insurance Trustee over to the Association, and the Association shall promptly contract for the repair and restoration of the damage.

3. If the damage or loss involves individual Units encumbered by Institutional Mortgages, as well as to the Common Elements, or if the damage is limited to the Common Elements alone but is in excess of \$10,000.00, the insurance proceeds shall be disbursed by the Insurance Trustee for the repair and restoration of the property upon the written

direction and approval of the Association. The Insurance Trustee may rely upon the certificates of the Association as to the payees and the amounts to be paid from said proceeds.

4. Subject to the foregoing, the Board of Directors of the Association shall have the right and obligation to negotiate and contract for the repair and restoration of the Condominium Property.

5. If the net proceeds of the insurance are insufficient to pay for the estimated cost of restoration and repair (or for the actual cost thereof if the work has actually been done), the Board of Directors shall promptly, upon determination of the deficiency, levy a special Assessment against all Units in proportion to each Unit's share in the Common Elements (regardless of whether all of the Common Elements are affected), for that deficiency. The special Assessment funds and funds from individual Unit charges, if any, shall be delivered by the Association to the Insurance Trustee and shall be added by the Insurance Trustee to the proceeds available for the repair and restoration of the Condominium Property.

G. "Very Substantial" Damage. As used in this Declaration, or in any other context dealing with this Condominium, the term "very substantial" damage shall mean loss or damage whereby 75 % or more of the total unit space in the Condominium is rendered untenable, in the sole discretion of the Board of Directors, or loss or damage whereby 75 % or more of the total amount of insurance coverage placed becomes payable. Should such "very substantial" damage occur, then:

1. The Board of Directors of the Association shall promptly obtain reliable and detailed estimates of the cost of repair and restoration thereof and the net amount of insurance proceeds available for restoration and repair.

2. Thereupon, a special meeting of the members of the Association shall be called by the Board of Directors of the Association, to be held not later than 60 days after the casualty, to determine the wishes of the members of the Association with reference to abandonment of the Condominium project, subject to the following:

a. If the net insurance proceeds available for restoration and repair are sufficient to cover the cost thereof, so that no special Assessment is required, then the Condominium Property shall be restored and repaired, unless members holding not less than 66-2/3% of the total votes of the Association shall vote to abandon the Condominium project, in which event the Condominium Property shall be removed from the provisions of the Act, in accordance with Section 718.117 of the Act.

b. If the net insurance proceeds available for restoration and repair are not sufficient to cover the cost thereof, so that a special Assessment will be required, then if members holding in excess of 33-1/3% of the total votes of the Association vote against such special Assessment, the Condominium shall be abandoned and the Condominium Property shall be removed from the provisions of the Act in accordance with Section 718.117 of the Act. In the event members holding not less than 66-2/3% of the total votes of the Association vote in favor of a special Assessment, the Association shall immediately levy such special Assessment and, thereupon, the Association shall proceed to negotiate and contract for such repairs. The special

Assessment funds shall be delivered by the Association to the Insurance Trustee and shall be added by said Insurance Trustee to the proceeds available for the repair and restoration of the Condominium Property. The proceeds shall be disbursed by the Insurance Trustee for the repair and restoration of the Condominium Property, as provided in Paragraph D of this Article.

c. In the event any dispute shall arise as to whether or not "very substantial" damage has occurred, it is agreed that a determination made by the Board of Directors of the Association shall be binding upon all Unit Owners.

H. Surplus. It shall be presumed that the first monies disbursed in payment of costs of repair and restoration shall be from the insurance proceeds; and if there is a balance remaining in the funds held by the Insurance Trustee after the payment of all costs of the repair and restoration, such balance may be retained as a reserve, or wholly or partly distributed, at the discretion of the Board of Directors of the Association. In the event of distribution, then the Insurance Trustee shall distribute any such balance to the beneficial owners of the fund in the manner elsewhere stated.

I. Plans and Specifications. Any repair and restoration must be substantially in accordance with the plans and specifications for the original building, or as the building was last constructed, or according to the plans approved by the Board of Directors of the Association, which approval shall not be unreasonably withheld. If any material or substantial change is contemplated, the approval of all affected Unit Owners and Institutional Mortgagees shall also be required. The Insurance Trustee shall not be obligated or required to inquire into or determine any matters concerning the plans or specifications of any repairs, restoration or rebuilding.

J. Association's Power to Compromise Claim. The Association is hereby irrevocably appointed agent for each Unit Owner for the purpose of compromising and settling claims arising under insurance policies purchased by the Association, and to execute and deliver releases therefor upon the payment of claims.

K. Worker's Compensation. To the extent available, a workmen's compensation policy shall be obtained by the Association to meet the requirements of law. In addition, the Association shall obtain such other insurance coverages as the Association shall reasonably determine is necessary for the Unit Owners and the Condominium.

L. Insurance on the Unit. Each individual Unit Owner shall purchase at Unit Owner's expense, liability insurance to cover accidents occurring within the Unit Owner's Unit, and shall purchase condominium owner's insurance and insurance upon the Unit Owner's personal property and such insurance, where applicable, shall contain a waiver of subrogation, if available.

M. Waiver. If available, and where applicable, the Association shall endeavor to obtain policies which provide that the insurance company waives its right of subrogation as to any claims against Unit Owners, the Association and their respective servants, agents and guests. Each Unit Owner and the Association hereby agrees to waive any claim against each other and against other Unit Owners for loss or damage for which insurance hereunder is carried, to the

extent that the coverage is adequate to compensate for the loss, where the insurer has waived its rights of subrogation as aforesaid.

## XX. EMINENT DOMAIN OR CONDEMNATION PROCEEDINGS

If eminent domain or condemnation proceedings are successfully litigated against all or any part of the Condominium Property, the entire eminent domain or condemnation award is to be secured to the Association for the use and benefit of Unit Owners and their mortgagees as their interests may appear, in accordance with the percentage of ownership of the Common Elements herein provided. Each Unit Owner, by acceptance of a deed of conveyance, acknowledges that the Association may act, as attorney-in-fact, for each Unit Owner in any such eminent domain or condemnation proceeding and in negotiations, settlements and agreements with the appropriate governmental condemning authority. The Association shall give prompt written notice to each Unit Owner and to each holder of a mortgage of record of any such eminent domain or condemnation proceeding, and shall take no action in any such proceedings that will disturb any mortgagee's lien priority.

## XXI. RULES AND REGULATIONS

A. As to the Common Elements. The Board of Directors may, by a 66-2/3% vote, from time to time, adopt or amend previously adopted administrative rules and regulations governing the details of the operation, use, maintenance and control of the Common Elements and Limited Common Elements of the Condominium and any facilities or services made available to the Unit Owners. The Board of Directors shall, from time to time, post at a conspicuous place on the Condominium Property, a copy of the rules and regulations adopted, from time to time, by the Board of Directors.

B. As to Units. The Board of Directors may, by a 66-2/3% vote, from time to time, adopt or amend previously adopted rules and regulations governing and restricting the use and maintenance of the Unit(s), Garage(s) and Storage Rooms, provided, however, that copies of such rules and regulations are furnished to each Unit Owner prior to the time the same become effective, and where applicable or desirable, copies thereof shall be posted at a conspicuous place on the Condominium Property.

C. Rules and Regulations. All rules and regulations adopted by the Board of Directors shall be deemed in effect until amended by the Board of Directors, and shall apply to and be binding upon all Unit Owners. The Unit Owners shall, at all times, obey said rules and regulations and shall use their best efforts to see that they are faithfully observed by their families, guests, invitees, servants and lessees. In order to change, amend or vary old or present rules and regulations and/or adopt new rules and regulations, the same shall be duly passed by at least a 66-2/3% vote or consent of the Board of Directors; however, no vote of the membership shall be required. A change, amendment or adoption of a rule and regulation shall not require an amendment to the Declaration of Condominium or of the By-Laws, unless such change, amendment or adoption of a rule and regulation would conflict, in any manner, with any provision of this Declaration and/or the By-Laws. The rules and regulations in effect as of the date of this Declaration are attached hereto as Exhibit "F".

## XXII. MANAGEMENT AGREEMENT

The Board of Directors of the Association may enter into a contract with any firm, person or corporation for the management of the Condominium Property. However, the Association shall, at all times, retain the powers and duties to be exercised by or under the authority of the Board of Directors.

## XXIII. TERMINATION OF CONDOMINIUM

The Condominium may be terminated in the following manner:

A. Destruction. If it is determined in the manner provided in Article XIX that the Condominium Property shall not be reconstructed, the Condominium will be terminated.

B. Agreement. As provided in Section 718.117 of the Act, the Condominium may be terminated at any time by the approval in writing of all Unit Owners and all record owners of mortgages encumbering Units.

If the proposed termination is submitted to a special meeting of the members of the Association and if the approval of such termination by members holding not less than 75% of the total votes of the Association and their mortgagees is obtained, in writing, then not later than one hundred twenty (120) days from the date of such special meeting, the approving Unit Owners (through the Association) shall buy all of the Units of the disapproving Unit Owners. The vote of those Unit Owners approving the termination shall be irrevocable. Any Unit Owner voting against the termination, or not voting, may within fifteen (15) days from the date the vote was taken, change or cast his vote in favor of termination by delivering written notification thereof to the Secretary of the Association. The purchase of all Units of non-approving Unit Owners shall be effected upon the following terms:

1. Exercise of Option. The Association shall deliver, or mail by registered mail, an agreement to purchase, signed by the President or Vice President of the Association, to each of the non-approving Unit Owners. The agreement shall be conditioned upon the purchase of all Units owned by Unit Owners not approving the termination.

2. Price. The sales price for each Unit shall be the fair market value as determined between the Seller and the Association. In the absence of agreement on the sales price of any Unit within thirty (30) days after the vote to terminate, the sales price shall be determined by a board of three (3) appraisers doing business in St. Johns County, one such appraiser being appointed by each of the selling Unit Owner and the Association, and the third being appointed by the first two appraisers. A judgment of specific performance of the sale, at the sales price determined by the appraiser, may be entered in any court of competent jurisdiction.

3. Payment. The purchase price shall be paid in cash.

4. Form. The contract shall be in the form of the Standard Deposit Receipt and Contract for Sale and Purchase then in use in St. Johns County, Florida.



5. Closing. The sale of all Units shall be closed simultaneously and within sixty (60) days following the determination of the sales price of the last Unit to be purchased.

C. Certificate. The termination of the Condominium in either of the foregoing manners shall be evidenced by a certificate of the Association, executed by its President (or Vice-President) and Secretary, certifying the fact of the termination, which shall become effective upon the certificate being recorded in the Public Records of St. Johns County, Florida.

D. Shares of Owners After Termination. After termination of the Condominium, the Unit Owners shall own the Condominium Property and all assets of the Association applicable to this Condominium as tenants in common of undivided shares that shall be equal to the sum of the undivided shares in the Common Elements appurtenant to the Units prior to termination, so that the sum total of the ownership shall equal 100%.

#### XXIV. ASSIGNABILITY OF RIGHTS OF DEVELOPER

The rights and privileges reserved in this Declaration of Condominium and in the Exhibits attached hereto in favor of the Developer are freely assignable, in whole or in part, and without the necessity for any consideration being paid to the Association or to any of the Unit Owners in this Condominium, by the Developer to any party who may be hereafter designated by the Developer to have and exercise such rights, and such rights may be exercised by the nominee, assignee or designee of the Developer and/or may be exercised by the successor or successors-in-interest of the Developer and/or by the successor or successors-in-interest of the nominees, assignees or designees of the Developer and/or by grantees from the Developer (including mortgagees accepting deeds from the Developer in lieu of foreclosure) and/or by successors in title to the Developer through mortgage foreclosure.

#### XXV. EXECUTION OF DOCUMENTS REQUIRED BY ST. JOHNS COUNTY AND/OR BY THE STATE OF FLORIDA

The Developer's plan for the development of this Condominium may require, from time to time, the execution of certain documents required by St. Johns County and/or by the State of Florida including, but not limited to, easements and restrictive covenants affecting the Condominium Property. To the extent that said documents require the joinder of any or all of the Unit Owners in this Condominium, each of said Unit Owners does hereby irrevocably give and grant to the Developer, or any of its officers, individually, full power-of-attorney to execute said documents as such Unit Owner's agent and in his place and stead.

#### XXVI. DEVELOPER'S RIGHT TO AMEND DECLARATION OF CONDOMINIUM

Developer shall have the right to amend the Declaration of Condominium, without the approval of a majority of the total votes of the Association except with respect to the following matters as to which approval and joinder of all Unit Owners and all holders of liens on the affected Units (which shall mean all Units as to item D below) shall be required:

- A. Make any change in the configuration or size of any Unit in any material fashion.
- B. Materially alter or modify the appurtenances to any Unit.

C. Change the proportion or percentage by which the Unit Owner shares the Common Expense of the Condominium, and owns the Common Surplus of the Condominium.

D. Permitting timeshare estates to be created in any Unit.

XXVII. USE RESTRICTIONS

To provide for a congenial occupation of the Condominium and to provide for the protection of the value of the individual Units, the use of the Condominium Property is restricted in accordance with the following provisions:

A. Each Unit shall be used and occupied by the respective Unit Owner, his tenants, family or guests as a private single-family residence or vacation home, and for no other purpose, except where specific exceptions are made in this Declaration. Nothing contained in this Section XXVII shall preclude ownership of a unit by a corporation, partnership or association, so long as occupation by these entities is residential in nature and not for the purpose of operating a business.

B. No unreasonable nuisance shall be allowed upon the Condominium Property, nor shall any practice be allowed which will unreasonably interfere with the peaceful possession and proper use of the Condominium Property by residents.

C. No Unit Owner shall permit anything to be done or kept in his unit which will increase the rate of insurance on the Condominium Property.

D. No unlawful use shall be made of the Condominium Property nor of any Unit, Garage, Storage Room or any part thereof.

E. All signs, billboards and advertising structures of any kind are prohibited, except building and subcontractor signs during construction periods, condominium identification signage, and one (1) "for sale" sign for each unit offered for sale. Except as provided in this paragraph, no signs may be nailed or attached to trees, placed in windows of units, or affixed to the Common Elements or Limited Common Elements. "For sale" signs shall be placed only in designated areas on the Common Elements. Sign posts shall be no taller than twenty-four inches (24") measured from the ground to the bottom of the sign, and signs shall not exceed four (4) square feet without prior approval by the Association. All "for sale" signs shall be approved by the Association before they are placed in the designated area. The Association may withhold approval solely on aesthetic grounds.

F. Drapery or window treatment visible from outside a Unit shall be white or beige or other shade or color approved by the Association. No sheets or aluminum foil shall be permitted in any window. Solar film may be installed with written consent of the Association if it is non-metallic in appearance. No signs shall be placed in any window of any Unit.

G. The parking of vehicles in the Condominium Property is restricted as follows:

1. Automobiles. Automobiles without any advertising or logos on the vehicle shall be permitted to be parked in parking areas and garages. Automobiles with advertising or logos shall be parked only in garages.

2. Sport Utility Vehicles and Passenger Vans. Sport utility vehicles ("SUV's" and passenger vans not outfitted for recreational purposes and without any advertising or logos shall be permitted to be parked in parking areas and garages. SUV's and passenger vans outfitted for recreational purposes or with advertising or logos shall be permitted only in garages.

A "passenger van" is a van that weighs less than five thousand (5,000) pounds, has seating for more than two (2) passengers, and has non-commercial license plates. "Outfitted for recreational purposes" shall mean a van that has running water, LP gas or sanitary waste facilities. No removable ladders or other commercial equipment shall be stored on the exterior of any passenger van. A "non-passenger van" is any van that does not comply with the definition of a "passenger van." A non-passenger van shall be subject to the same restrictions as a truck rated one-half (1/2) ton or less, as more fully provided in subparagraph 3 below.

3. Trucks and Non-Passenger Vans. Pickup trucks without any advertising or logos, used as the resident's regular or usual form of transportation and non-passenger vans without any advertising or logos shall be permitted in the Condominium Property if parked in parking areas or garages. Pickup trucks and non-passenger vans with any advertising or logos, or trucks not the resident's regular or usual form of transportation, are not permitted to be parked in the Condominium Property unless present solely for the actual and continuous repair or construction of a residence or parked in garages.

4. Boats, Campers, Trailers. Boats, campers and trailers shall be permitted to be parked in the Condominium Property only if parked in garages or in areas designated by the Board of Directors.

5. Travel Trailers, Motor Coaches, Motor Homes, Mobile Homes. Travel trailers, motor coaches, motor homes, mobile homes and any other trailer or vehicle not specifically permitted by Sections 1 through 4 above shall not be parked in the Condominium Property at any time except in areas designated by the Board of Directors.

6. Hardship. In cases of undue hardship the Association may grant a specific exception of limited duration to the provisions of this Section upon written request to the Association.

7. Lawns, Streets. No vehicle shall be parked on any lawn, yard, travel area of streets, or other area not intended for vehicular parking.

H. Trash, garbage or other waste shall not be kept on any unit except in sanitary containers or garbage compactor units. Garbage containers, if any, shall be kept in a clean and sanitary condition, and shall be so placed or screened as not to be visible from any road or adjacent property within sight distance of the Unit at any time except during refuse collection. No outside burning of wood, leaves, trash, garbage or household refuse shall be permitted. Clotheslines, if any, shall be contained within the Unit. No clothing or cleaning articles shall be hung or displayed on any part of the Unit so that they are visible outside of the Unit.

I. No animals, except usual household pets weighing less than 75 pounds, shall be kept on any Unit. The number of animals kept as pets other than fish (e.g., dogs, cats, reptiles) shall not exceed two (2) in any one household. Pets shall be kept only in the Unit. Residents shall not breed such animals as a hobby or for profit, and are encouraged to have such animals neutered. No animal shall be permitted off the Unit unless on a leash. Pets will be permitted to relieve themselves only in designated areas. Owners will be required to clean up after any pet that relieves itself in any area other than a designated area. No pet or animal that is exotic or of a vicious breed shall be maintained or harbored within a Unit. No pet or animal shall be maintained or harbored within a Unit that would create a nuisance to any other Unit Owner or lessee. A determination by the Board of Directors that a pet or animal maintained or harbored within a Unit is vicious, creates a nuisance, or is exotic shall be binding and conclusive on all parties. This provision may be amended only upon the affirmative vote of seventy-five (75 %) percent of all Unit Owners. The Board of Directors may adopt such further rules and regulations regarding pets as the Board of Directors deems to be desirable

J. All mailboxes and name and address graphics shall be uniform in appearance and location. The appearance and location of mailboxes and graphics will be determined by Developer and may not be changed afterwards without the prior written consent of the Association.

#### XXVIII. CONDOMINIUM WORKING CAPITAL FUND

At the time the Developer closes upon the sale of a Unit to a purchaser (purchaser thereby becoming a Unit Owner in the Condominium), the purchaser shall deposit with the Association an amount equal to two (2) monthly installments of the Common Expenses assessed to the purchaser's Unit. This sum shall be deposited into a working capital account ("Condominium Working Capital Fund") for the purpose of having funds available for initial and non-recurring items, capital expenses, permit fees, licenses, utility deposits and advance premiums for insurance policies and coverages pursuant to this Declaration and the Exhibits attached hereto. The Condominium Working Capital Fund shall not be commingled for the purposes of investment by the Association with any of its other funds; however, separate ledgers must be maintained for each account. In no event shall the Developer receive reimbursement from the Condominium Working Capital Fund for those expenses which it is obligated to pay pursuant to the provisions of Article XIV hereinabove and Section 718.116(9)(a) of the Act.

#### XXIX. LEASES OF UNITS

Without the prior, written consent of the Board of Directors which may be granted or withheld in the sole discretion of the Board of Directors a Unit may not be leased for a time period of less than sixty (60) days or more than two (2) times per year. Each prospective tenant for whom lease approval by the Board of Directors is required shall be required to complete an application, the form of which shall be provided by the Association, provide a list of credit references to the Association, and pay a screening fee to the Association, the amount of which shall be established from time to time by the Board of Directors. Within seven (7) days from the date of receipt of said application and list of credit references, the Board of Directors of the Association shall either approve or disapprove the proposed tenant in writing, and shall notify the Unit Owner of its decision. In the event the Board of Directors shall fail to approve or

disapprove the proposed tenant and leasing of the Unit thereto within said seven (7) days, the failure to act as aforesaid shall be considered an approval of the tenant and the authority of the Unit Owner to enter into the lease. The Association shall have the right to refuse to give written approval to any leasing of the Unit until all Assessments owed with respect to the particular Unit are paid in full. No charge or authorization shall be required in connection with an extension or renewal of the lease. Any lease of a Unit not authorized pursuant to the terms of this Declaration shall be void unless subsequently approved by the Association.

### XXX. REMEDIES

A. Relief. Each Unit Owner and the Association shall be governed by and shall comply with the provisions of this Declaration as they may exist from time to time. A violation thereof shall entitle the appropriate party to institute an action to recover sums due for damages, injunctive relief, foreclosure of lien or any combination thereof, or any other action available pursuant to the Act, at law, or in equity. Suit may be brought by the Association or, if appropriate, by one or more Unit Owners and the prevailing party shall be entitled to recover reasonable attorneys' fees. Each Unit Owner acknowledges that the failure to comply with any of the provisions of this Declaration shall or may constitute an injury to the Association or to other Unit Owners and that such injury may be irreparable.

B. Costs and Attorneys' Fees. In any proceeding arising because of an alleged default, act, failure to act, or violation by the Unit Owner or the Association, including the enforcement of any lien granted pursuant to this Declaration or its Exhibits, the prevailing party shall be entitled to recover the costs of the proceedings, including reasonable attorneys' fees. Further, in the event that proceedings are instituted by or against the Developer or against any affiliated entity of the Developer or against any individual connected with the Developer (including, but not limited to, the parent company of the Developer and/or any subsidiary of the Developer and/or any subsidiary of either of the general partners of the Developer and/or the initial directors of the Association) for any reason whatsoever, including but not limited to: (i) actions for declaratory judgment, (ii) any claim that any of the above have not complied with their obligations under the Prospectus for this Condominium, this Declaration and its Exhibits, or (iii) that any provision of the same is unconscionable or violates any State or Federal Law or regulation, then the prevailing party shall be entitled to recover all costs of the proceeding. Said recoverable costs shall include, but are not limited to, reasonable attorneys' fees at all levels of the proceeding, including appeals, together with all costs including those not normally allowed in actions at law such as, but not limited to, copies of depositions and other documentation and exhibits, whether or not used at trial; travel expenses for consultants and/or witnesses for the purpose of testifying at trial or deposition; consultants fees; expert witness fees for testifying at trial or deposition, together with such additional fees as the expert witness may charge in connection with his preparation for giving such testimony at deposition or at trial whether or not the witness shall actually appear or be called upon to testify.

C. No Waiver. The failure of the Association, the Developer or Unit Owners to enforce any right, provision, covenant or condition created or granted by this Declaration, the Act, the Articles of Incorporation, the By-Laws and/or any rules and regulations adopted with respect to any portion of the Condominium Property, shall not constitute a waiver of the right of said party to enforce such right, provision, covenant or condition in the future.

D. Rights Cumulative. All rights, remedies and privileges granted to the Association, the Developer and Unit Owners pursuant to the provisions of this Declaration shall be deemed to be cumulative and the exercise of any one or more shall not be deemed to constitute an election of remedies, nor shall it preclude the party thus exercising the same from exercising such other and additional rights, remedies or privileges as may be available to such party at law or in equity. Each Unit Owner agrees in any proceeding brought pursuant to the provisions hereof not to plead or defend the same on the theory of "election of remedies".

### XXXI. PROVISIONS FOR A PHASE CONDOMINIUM

Developer reserves the right to develop the Condominium in three (3) phases. However, Developer has no obligation to Unit Owners and/or the Association to develop any subsequent phase of the Condominium (as hereinafter described). In the event Developer elects to develop the Condominium in phases, the following shall apply:

A. The legal description of Phase I of the Condominium, being the phase declared Condominium pursuant to this Declaration, is set forth on Exhibit A of this Declaration.

B. The legal descriptions of Phase II and Phase III of the Condominium are set forth on Exhibit B of this Declaration.

C. The survey, plot plans and floor plans for the improvements which Developer will construct and declare condominium pursuant to this Declaration are set forth in Exhibit B of this Declaration. The appearance of the buildings in subsequent phases may be substantially different from the buildings in Phase I although the Developer presently plans for such buildings to look the same as buildings in Phase I. Developer reserves the rights set forth in this Declaration as to Units in all subsequent phases, including, without limitation, the right to alter the size and interior design of all units owned by Developer.

D. The survey, plot plans and floor plans for the improvements which Developer may construct and declare as each subsequent phase of the Condominium are included in Exhibit B. Developer reserves the right to make changes to the layout of Phase II and Phase III of the Condominium, and to make non-material changes to the legal description of either Phase.

E. Phase I of the Condominium consists of 60 units. Phase II of the Condominium, if developed, will consist of not less than 64 Units, nor more than 80 Units. Phase III of the Condominium, if developed, will consist of not less than 64 Units, nor more than 80 Units. The Developer intends that the general size of Units in Phase II and Phase III of the Condominium will be approximately the same as the general size of the Units in Phase I of the Condominium. Units in each Phase will be one of three types, each having a minimum of 1,800 square feet and a maximum of 2,750 square feet of floor space, including balconies.

F. Each of the Phase I unit's ownership of common elements and common surplus and their share of common expenses is set forth in Article VII of this Declaration. The manner of calculating each condominium unit's percentage ownership of common elements and common surplus and their percentage share of common expenses as subsequent phases are added to this Condominium is as follows: the square footage of the air conditioned area of the Unit divided by the total square footage of the air conditioned area of all Units developed as part of this

Condominium equals the share of common elements, common surplus, and common expenses of the Unit. At such time as each of Phase II and Phase III is developed and added to the Condominium, the ownership of common elements and common surplus and the share of common expenses of each unit in Phase I shall no longer be as set forth in Exhibit C, but shall be determined in the manner set forth in this Article XXXI and set forth in the Amendment to the Declaration submitting such subsequent phase to condominium ownership.

G. Phase II of the Condominium, if built is expected to include a tennis center containing a maximum of 2,500 square feet and two or three tennis courts.

H. The membership vote and ownership in the Association attributable to each unit in Phase I shall be one (1) vote per unit or a total of sixty (60) members and votes for Phase I. In the event Phase II is developed and added to the Condominium, then the membership vote and ownership in the Association attributable to each unit in Phase I and Phase II shall be one (1) vote per unit. In the event Phase II of the Condominium is not developed and added, then the membership vote and ownership in the Association shall be one (1) vote per unit for each unit in Phase I as provided in this Declaration.

If Phase III is developed and added to the Condominium, then the membership vote and ownership in the Association attributable to each unit in Phase I, II and III shall be one (1) vote per unit. If Phase III of the Condominium is not developed and added, then the membership vote and ownership in the Association shall be one (1) vote per unit for each unit in Phase I and II.

I. No time-share estates will be created for any of the units in this Condominium.

J. If any subsequent phase of the Condominium is not built, then the units which are built are entitled to and shall share one hundred percent (100%) ownership of all common elements within the Condominium. Unit Owners shall have no rights in any subsequent phase unless and until an amendment to this Declaration is recorded in the public records of St. Johns County, Florida.

K. Developer is not required, under the Declaration or otherwise, to convey any additional lands or facilities to the Condominium after the completion of construction of Phase I of the Condominium or after the completion of any additional phase, in the event an additional phase is added as part and parcel of this Condominium.

Notwithstanding the provisions of Section 718.110, Florida Statutes, amendment to the Declaration of Condominium adding any phase to the Condominium shall not require the execution of any amendment or consent by Unit Owners (other than the Developer), mortgagees, lienors or the Association.

Phases II and III must be added to the Condominium and comply with the Act by December 31, 2007, or the right to add any phase not previously added will expire.

L. The developer of any additional phase may be the Developer or the assignee or successor in whole or in part of the Developer.

M. Developer has no obligation or responsibility to cause any additional phase or its improvements to be constructed. In the event an additional phase is added as part of this Condominium, then the Developer shall be the sole judge and have sole discretion as to the size, content, style, amount and plans and specifications of and for any additional phase and all of its improvements, amenities, equipment and personalty, provided that same is in accordance with the provisions of this paragraph. Notwithstanding anything to the contrary contained herein or in the other condominium documents, Developer has the right to develop or sell the Phase II and Phase III property in any manner or to any person or entity as it shall determine in its sole and absolute discretion, free and clear of any limitation, restriction or cloud which could be created by or interpreted from this Article.

### XXXII. ADDITIONAL PROVISIONS

A. Should any dispute or litigation arise between any of the parties whose rights and/or duties are affected or determined by this Declaration or any of the Exhibits attached hereto, said dispute or litigation shall be determined pursuant to the laws of the State of Florida.

B. In the event that any of the terms, provisions or covenants of this Declaration or any of the Exhibits attached hereto are held to be partially or wholly invalid or unenforceable for any reason whatsoever, such holdings will not affect, alter, modify, or impair in any manner whatsoever any of the other terms, provisions or covenants hereof or the remaining portions of any terms, provisions or covenants held to be partially invalid or unenforceable herein.

C. Except as may be provided in Article XXVI herein, unless all affected Institutional Mortgagees have given their prior written approval, the Association shall not be entitled to: (1) change the pro rata interest or obligations of any Unit for purposes of levying Assessments and charges and determining shares of Common Elements and Common Surplus of the Condominium; (2) partition or subdivide any Unit or the Common Elements of the Condominium; or (3) by act or omission seek to abandon the Condominium regime, except as may be provided herein or by statute in case of substantial loss to the Units and to the Common Elements of the Condominium.

D. Notwithstanding anything to the contrary herein, nothing shall prevent the combining of Units in the Condominium, by appropriate amendment to the Declaration, but said combined Units shall retain their original appurtenant shares of the Common Elements, Common Expenses and Common Surplus and voting rights in the Association.

E. Whenever the context so permits, the use of the plural shall include the singular, and any gender shall be deemed to include all genders.

F. Captions used in these documents are inserted solely as a matter of convenience and shall not be relied upon or used in construing the effect or meaning of any of the text of the documents.

G. An affirmative vote of at least 66-2/3% of the total votes of the Association shall be required before the Association may bring any cause of action against the Developer for any reason whatsoever.



H. Upon written request, Institutional Mortgagees shall have the right to examine the books and records of the Association. In addition, upon written request, Institutional Mortgagees shall be entitled to receive written notification from the Association of:



1. Any condemnation loss or any casualty loss which affects a material portion of the Condominium Property or any Unit encumbered by an Institutional Mortgage;
2. Any delinquency in the payment of Assessments or charges owed by an Owner of a Unit encumbered by an Institutional Mortgage, which remains uncured for a period of 60 days;
3. Any lapse, cancellation or material modification of any insurance policy or fidelity bond maintained by the Association.

I. Upon written request from the Department of Housing and Urban Development or from the Federal National Mortgage Administration or from the Federal Home Loan Mortgage Corporation or from the Veterans Administration, the Association shall prepare and furnish within a reasonable period of time, an audited financial statement of the Association for the immediately preceding fiscal year of the Association.

J. Neither the Association nor the Unit Owners shall interfere with the sale of Units by the Developer. As long as the Developer owns at least one (1) Unit in the Condominium, the Developer (or its duly authorized agents or assigns) may make such use of the unsold Unit(s) and the Common Elements (including any portions of the Common Elements designated as offices on the Plot Plan, Survey and Graphic Description attached hereto as Exhibit "B") as may facilitate the Developer's administrative activities (which administrative activities may include, but shall not be limited to, administration of the Association, bookkeeping, post closing repair work and Developer sales, leasing and closing functions) and sales (with respect to units within this Condominium and/or with respect to the sale and/or lease of units in other developments owned by the Developer and/or by entities affiliated with the Developer) including, but not limited to, the maintenance of administrative offices and the maintenance of sales and/or leasing offices, for the showing of the Unit(s) and for the display of signs, billboards, placards and visual promotional materials. The Developer may use unsold Units as model units. Any administrative offices and/or sales and leasing offices and/or model units and all personal property, furnishings and signs contained therein and/or appurtenant thereto shall not be considered Common Elements, but shall remain the separate property of the Developer.

IN WITNESS WHEREOF, the Developer has caused this Declaration of Condominium to be executed this 2nd day of April, 2002.

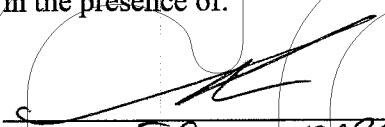
Signed, sealed and delivered  
in the presence of:

  
Printed: Edward M. Scie  
  
Printed: CASSANDRA COX

OCEAN GRANDE SERENATA, L.L.C., a  
Florida limited liability company

By:   
Wallace R. Devlin, Manager

STATE OF Florida )  
COUNTY OF Duval ) SS:

The foregoing instrument was acknowledged before me this 27<sup>th</sup> day of March, 2002, by Wallace R. Devlin, as Manager of Ocean Grande Serenata, L.L.C., a Florida limited liability company, of and for and on behalf of Ocean Grande Serenata, L.L.C., a Florida limited liability company, who is personally known to me and who did not take an oath.

 Judy V Buckner  
My Commission DD088795  
Expires February 03, 2006

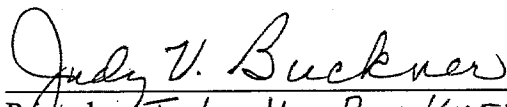
  
Printed Judy V. BUCKNER  
Notary Public, State and County aforesaid  
Commission No.: DD 088795  
My commission expires: 2/3/06

Signed, sealed and delivered  
in the presence of:

OCEAN GRANDE SERENATA, L.L.C., a  
Florida limited liability company

Cristina Vazquez  
 Printed: Cristina Vazquez

Seido A. B. B. B.  
 Printed: Seido A. B. B. B.

By: [Signature]  
 Luis Lamar, Manager

STATE OF FLORIDA )  
 ) SS:  
 COUNTY OF DADE )

The foregoing instrument was acknowledged before me this 22nd day of MARCH, 2002, by Luis Lamar, as Manager of Ocean Grande Serenata, L.L.C., a Florida limited liability company, of and for and on behalf of Ocean Grande Serenata, L.L.C., a Florida limited liability company, who is personally known to me and who did not take an oath.

Olivia Quintana  
 Printed OLIVIA QUINTANA  
 Notary Public, State and County aforesaid  
 Commission No.: CC970441  
 My commission expires: Sept. 25, 2004

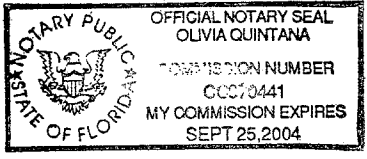

JOINDER AND CONSENT BY MORTGAGEE

The undersigned, First Union National Bank ("Mortgagee"), the holder of that certain Mortgage and Security Agreement executed by Ocean Grande Serenata, L.L.C., a Florida limited liability company ("Developer"), dated April 18, 2001, recorded at Official Records Book 1591, Page 511 of the Public Records of St. Johns County, Florida (the "Mortgage"), covering all of the property described on Exhibit A in the attached Declaration of Condominium of Ocean Grande at Serenata Beach, a Condominium (the "Declaration"), does hereby execute this joinder for the sole purpose of consenting to the recording of the Declaration, and subordinating the lien of the Mortgage to the provisions of the Declaration, but specifically reserving the consent right set forth in the following paragraph. By its execution hereof, Mortgagee does not make any representations or warranties with respect to any matters set forth in or pertaining to the Declaration or undertake any of the obligations or liabilities contained therein.

Mortgagee hereby expressly reserves the right to grant or withhold its consent to the addition of Phase II and/or Phase III to the Condominium Property as contemplated by Article XXXI of the Declaration. Furthermore, Developer's exercise of any of its rights under Article XXXI of the Declaration shall not be effective without the prior written consent of Mortgagee filed of record with the applicable amendment to the Declaration.

IN WITNESS OF THE FOREGOING, the Mortgagee has set Mortgagee's hand and seal the 28<sup>th</sup> day of March, 2002.

WITNESSES:

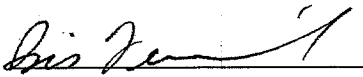
  
Isis Fernandez  
 [Print Name]

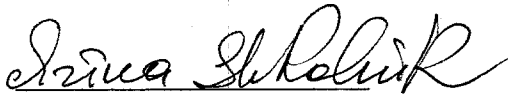
  
Irina Stokolnik  
 [Print Name]

FIRST UNION NATIONAL BANK

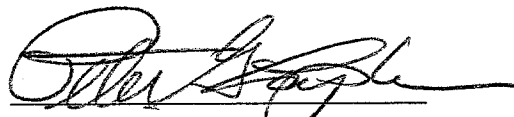
By:   
 Name: Peter G. Lapham  
 Title: Senior Vice President

OR1739PG1816

STATE OF FLORIDA

COUNTY OF MIAMI-DADE

The foregoing instrument was acknowledged before me this 28<sup>th</sup> day of March, 2002, by Peter M. Lapham as S.R. V. P. of FIRST UNION NATIONAL BANK, who is personally known to me/has produced \_\_\_\_\_ as identification.

(SEAL)

Printed/Typed Name: Isis Fernandez  
Notary Public-State of Florida  
Commission Number:



Isis Fernandez  
My Commission CC835709  
Expires June 18, 2003

## EXHIBIT A

LEGAL DESCRIPTION OF PARCEL 1:

A PORTION OF SECTIONS 19, AND 20, TOWNSHIP 6 SOUTH, RANGE 30 EAST, ST. JOHNS COUNTY, FLORIDA AND BEING MORE PARTICULARLY DESCRIBED AS FOLLOWS: FOR THE POINT OF REFERENCE COMMENCE AT THE SOUTHWESTERLY CORNER OF SAID SECTION 20, THENCE NORTH 00°45'00" WEST, ALONG THE WEST LINE OF SAID SECTION 20, 1486.69 FEET TO THE POINT OF BEGINNING.

FROM THE POINT OF BEGINNING THUS DESCRIBED, THENCE CONTINUE NORTH 00°45'00" WEST, CONTINUING ALONG SAID SECTION LINE, THE SAME BEING THE WESTERLY LINE OF LANDS DESCRIBED IN DEED RECORDED IN THE OFFICIAL RECORDS OF SAID COUNTY IN BOOK 662, PAGE 270, 625.30 FEET TO AN ANGLE POINT IN SAID DEED LINE; THENCE NORTH 06°06'30" WEST, CONTINUING ALONG SAID DEED LINE, 348.14 FEET; THENCE NORTH 83°53'30" EAST, 162.00 FEET; THENCE SOUTH 81°09'02" EAST, 69.29 FEET; THENCE SOUTH 51°04'36" EAST, 34.41 FEET; THENCE NORTH 46°25'39" EAST, 18.88 FEET; THENCE NORTH 16°57'44" EAST, 28.34 FEET; THENCE NORTH 09°02'51" EAST, 284.26 FEET; THENCE NORTH 84°04'22" EAST, 66.04 FEET; THENCE SOUTH 84°53'36" EAST, 39.23 FEET; THENCE NORTH 76°23'00" EAST, 122.19 FEET TO THE WESTERLY RIGHT-OF-WAY LINE OF STATE ROAD NO. A-1-A (A 100-FOOT RIGHT-OF-WAY AS NOW ESTABLISHED); THENCE SOUTH 13°37'00" EAST, ALONG SAID RIGHT-OF-WAY LINE, 78.65 FEET; THENCE SOUTH 76°23'00" WEST, 122.19 FEET; THENCE SOUTH 00°56'17" WEST, 34.95 FEET; THENCE SOUTH 42°40'46" WEST, 161.23 FEET; THENCE SOUTH 05°35'10" EAST, 153.59 FEET; THENCE SOUTH 44°05'23" WEST, 128.89 FEET; THENCE SOUTH 45°39'07" EAST, 140.94 FEET; THENCE SOUTH 46°09'28" EAST, 80.65 FEET; THENCE SOUTH 40°56'20" EAST, 59.36 FEET; THENCE SOUTH 32°51'01" EAST, 53.44 FEET; THENCE SOUTH 34°53'37" EAST, 172.51 FEET; THENCE SOUTH 16°29'55" EAST, 53.83 FEET; THENCE SOUTH 03°51'07" WEST, 63.34 FEET; THENCE SOUTH 05°12'21" EAST, 10.36 FEET; THENCE SOUTH 18°31'11" EAST, 28.91 FEET; THENCE SOUTH 15°04'10" WEST, 153.71 FEET TO A POINT OF CURVATURE; THENCE IN A SOUTHEASTERLY DIRECTION, ALONG THE ARC OF A CURVE, SAID CURVE BEING CONCAVE NORTHEASTERLY AND HAVING A RADIUS OF 32.50 FEET, A CHORD BEARING AND DISTANCE OF SOUTH 36°20'20" EAST, 50.80 FEET; THENCE SOUTH 02°15'10" WEST, 70.54 FEET TO THE SOUTHERLY LINE OF LANDS DESCRIBED IN SAID OFFICIAL RECORDS BOOK 662, PAGE 270; THENCE SOUTH 89°15'00" WEST, ALONG SAID SOUTHERLY LINE, 550.51 FEET TO THE POINT OF BEGINNING.

EXHIBIT B

BUILDING NO. 4  
OCEAN GRANDE  
AT SERENATA BEACH,  
A CONDOMINIUM

COPY

STATE OF FLORIDA  
S.S.  
COUNTY OF DUVAL

BEFORE ME, the undersigned authority duly authorized to administer oaths and take acknowledgments, personally appeared LARRY G. EDDY, by me well known and known to me to be the person hereinafter described, who being by me first duly cautioned and sworn, deposes and says on oath as follows, to wit:

1. That he is duly registered and duly licensed land surveyor authorized to practice under the laws of the State of Florida.
2. Affiant hereby certifies that the attached sketch and floor plans marked Exhibit 1-3, as to BUILDING NO. 4 ONLY, together with the wording of the Declaration of Condominium is an accurate representation of the location and dimensions of BUILDING NO. 4 according to the plans and specifications, and that there can be determined therefrom the identification, location, dimensions and size of the common elements and of each condominium unit in BUILDING NO. 4. There may exist some variance between the proposed improvements and the improvements constructed therein.
3. That the improvements serving BUILDING NO. 4, including landscaping, utilities and access have been constructed. The improvements have been inspected, measured, and certified as substantially complete in accordance with the provisions of Florida Statute 718.014.

FURTHER AFFIANT SAYETH NAUGHT.

Tri-State Land Surveyors, Inc.

  
 Larry G. Eddy  
 Professional Land Surveyor No. 4144  
 State of Florida

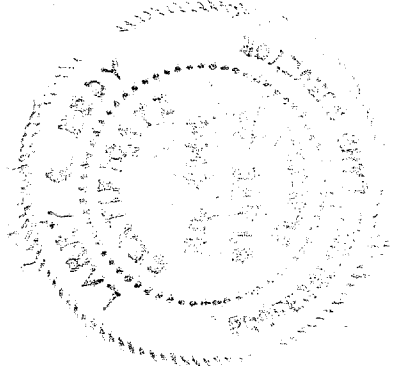

STATE OF FLORIDA  
COUNTY OF DUVAL

The foregoing instrument was acknowledged before me this 14 day of March, 2002 by LARRY G. EDDY, who is personally known to me and did take an oath.

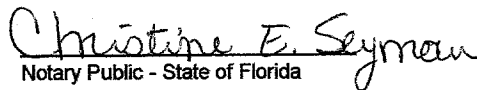
  
 Christine E. Seymour  
 Notary Public - State of Florida

Commission No. \_\_\_\_\_

CHRISTINE E. SEYMOUR  
 NOTARY PUBLIC - STATE OF FLORIDA  
 COMMISSION # CC906728  
 EXPIRES 1/31/2004  
 BONDED THRU ASA 1-888-NOTARY1

Certification





LEGAL DESCRIPTION OF PARCEL 1:

A PORTION OF SECTIONS 19 AND 20, TOWNSHIP 6 SOUTH, RANGE 30 EAST, ST. JOHNS COUNTY, FLORIDA AND BEING MORE PARTICULARLY DESCRIBED AS FOLLOWS: FOR THE POINT OF REFERENCE COMMENCE AT THE SOUTHWEST CORNER OF SAID SECTION 20, THENCE NORTH 07°45'00" WEST, ALONG THE WEST LINE OF SAID SECTION 20, 1486.69 FEET TO THE POINT OF BEGINNING.

FROM THE POINT OF BEGINNING THIS DESCRIBED, THENCE CONTINUE NORTH 07°45'00" WEST, CONTINUING ALONG SAID SECTION 20, THE SAME BEING THE WESTERLY LINE OF LANDS DESCRIBED IN DEED RECORDED IN THE OFFICIAL RECORDS OF SAID COUNTY IN BOOK 862, PAGE 270, 925.30 FEET TO AN ANGLE POINT IN SAID DEED LINE, THENCE NORTH 06°06'30" WEST, 89.28 FEET TO THE POINT OF BEGINNING, THENCE NORTH 83°53'30" EAST, 62.00 FEET, THENCE SOUTH 81°09'02" EAST, 1657.44 FEET, THENCE NORTH 34°53'30" WEST, 1218.19 FEET, THENCE NORTH 84°04'22" EAST, 68.04 FEET, THENCE SOUTH 81°09'02" EAST, 39.23 FEET, THENCE NORTH 76°23'00" WEST, 1424.49 FEET, THENCE SOUTH 07°55'17" WEST, 34.95 FEET, THENCE NORTH 82°40'46" WEST, 161.23 FEET, THENCE SOUTH 47°02'28" EAST, 80.65 FEET, THENCE SOUTH 44°00'23" WEST, 128.86 FEET, THENCE SOUTH 32°45'00" WEST, 1034.34 FEET, THENCE SOUTH 34°53'37" EAST, 1725.51 FEET, THENCE SOUTH 16°29'56" EAST, 53.83 FEET, THENCE SOUTH 05°10'17" WEST, 45.11 FEET, THENCE NORTH 10°38' FEET, THENCE SOUTH 18°31'11" EAST, 28.91 FEET, THENCE SOUTH 15°04'10" WEST, 153.71 FEET TO THE POINT OF BEGINNING. IN A SOUTHWESTERLY DIRECTION, ALONG THE ARC OF A CURVE, SAID CURVE BEING CONVEX SOUTHWESTERLY AND HAVING A RADIUS OF 1132.30 FEET, A CHORD BEARING AND DISTANCE OF SOUTH 36°20'27" EAST, 52.80 FEET, THENCE SOUTH 02°15'07" WEST, 50.42 FEET, THENCE SOUTH 11°37'07" WEST, 52.80 FEET, THENCE SOUTH 07°55'17" WEST, 34.95 FEET TO THE POINT OF BEGINNING.

LEGAL DESCRIPTION OF DRAINAGE EASEMENT "A" EXHIBIT A

A PORTION OF SECTION 20, TOWNSHIP 6 SOUTH, RANGE 30 EAST, ST. JOHNS COUNTY, FLORIDA AND BEING MORE PARTICULARLY DESCRIBED AS FOLLOWS: FOR A POINT OF REFERENCE COMMENCE AT THE SOUTHWEST CORNER OF SAID SECTION 20, THENCE NORTH 07°45'00" WEST, ALONG THE WESTERLY LINE OF SAID SECTION 20, 1486.69 FEET, THENCE NORTH 06°06'30" WEST, 89.28 FEET, THENCE NORTH 83°53'30" EAST, 62.00 FEET, THENCE SOUTH 81°09'02" EAST, 1657.44 FEET, THENCE NORTH 34°53'30" WEST, 1218.19 FEET, THENCE NORTH 84°04'22" EAST, 68.04 FEET, THENCE SOUTH 81°09'02" EAST, 39.23 FEET, THENCE NORTH 76°23'00" WEST, 1424.49 FEET, THENCE SOUTH 07°55'17" WEST, 34.95 FEET, THENCE NORTH 82°40'46" WEST, 161.23 FEET, THENCE SOUTH 47°02'28" EAST, 80.65 FEET, THENCE SOUTH 44°00'23" WEST, 128.86 FEET, THENCE SOUTH 32°45'00" WEST, 1034.34 FEET, THENCE SOUTH 34°53'37" EAST, 1725.51 FEET, THENCE SOUTH 16°29'56" EAST, 53.83 FEET, THENCE SOUTH 05°10'17" WEST, 45.11 FEET, THENCE NORTH 10°38' FEET, THENCE SOUTH 18°31'11" EAST, 28.91 FEET, THENCE SOUTH 15°04'10" WEST, 153.71 FEET TO THE POINT OF BEGINNING. IN A SOUTHWESTERLY DIRECTION, ALONG THE ARC OF A CURVE, SAID CURVE BEING CONVEX SOUTHWESTERLY AND HAVING A RADIUS OF 1132.30 FEET, A CHORD BEARING AND DISTANCE OF SOUTH 36°20'27" EAST, 52.80 FEET, THENCE SOUTH 02°15'07" WEST, 50.42 FEET, THENCE SOUTH 11°37'07" WEST, 52.80 FEET, THENCE SOUTH 07°55'17" WEST, 34.95 FEET TO THE POINT OF BEGINNING.

FROM THE POINT OF BEGINNING THIS DESCRIBED, THENCE CONTINUE NORTH 07°45'00" WEST, CONTINUING ALONG SAID SECTION 20, THE SAME BEING THE WESTERLY LINE OF LANDS DESCRIBED IN DEED RECORDED IN THE OFFICIAL RECORDS OF SAID COUNTY IN BOOK 862, PAGE 270, 925.30 FEET TO AN ANGLE POINT IN SAID DEED LINE, THENCE NORTH 06°06'30" WEST, 89.28 FEET TO THE POINT OF BEGINNING, THENCE NORTH 83°53'30" EAST, 62.00 FEET, THENCE SOUTH 81°09'02" EAST, 1657.44 FEET, THENCE NORTH 34°53'30" WEST, 1218.19 FEET, THENCE NORTH 84°04'22" EAST, 68.04 FEET, THENCE SOUTH 81°09'02" EAST, 39.23 FEET, THENCE NORTH 76°23'00" WEST, 1424.49 FEET, THENCE SOUTH 07°55'17" WEST, 34.95 FEET, THENCE NORTH 82°40'46" WEST, 161.23 FEET, THENCE SOUTH 47°02'28" EAST, 80.65 FEET, THENCE SOUTH 44°00'23" WEST, 128.86 FEET, THENCE SOUTH 32°45'00" WEST, 1034.34 FEET, THENCE SOUTH 34°53'37" EAST, 1725.51 FEET, THENCE SOUTH 16°29'56" EAST, 53.83 FEET, THENCE SOUTH 05°10'17" WEST, 45.11 FEET, THENCE NORTH 10°38' FEET, THENCE SOUTH 18°31'11" EAST, 28.91 FEET, THENCE SOUTH 15°04'10" WEST, 153.71 FEET TO THE POINT OF BEGINNING. IN A SOUTHWESTERLY DIRECTION, ALONG THE ARC OF A CURVE, SAID CURVE BEING CONVEX SOUTHWESTERLY AND HAVING A RADIUS OF 1132.30 FEET, A CHORD BEARING AND DISTANCE OF SOUTH 36°20'27" EAST, 52.80 FEET, THENCE SOUTH 02°15'07" WEST, 50.42 FEET, THENCE SOUTH 11°37'07" WEST, 52.80 FEET, THENCE SOUTH 07°55'17" WEST, 34.95 FEET TO THE POINT OF BEGINNING.

- 1. THIS IS NOT A BOUNDARY SURVEY.
- 2. ELEVATIONS SHOWN ARE REFERENCED TO SITE BENCHMARKS.
- 3. BENCHMARKS ARE SHOWN AS BUILT CONDUITS.
- 4. UNDERGROUND LOCATIONS PROVIDED BY POSSESSORS.
- 5. DEMONSTRATION FILE PROVIDED BY OTHERS.
- 6. CLEAR 66'-BUILT CONDUITS.



PREPARED FOR: OCEAN GRANDE SPREMA, L.L.C.  
 THIS SURVEY DEPICTED HERE IS NOT COVERED BY PROFESSIONAL LIABILITY INSURANCE.  
 MICHAEL T. DANTZLER  
 PROFESSIONAL SURVEYOR & MAPPER  
 3888 90-13 SOUTH, ELKTON, FLORIDA 32033  
 Phone #: (904) 692-2676 Fax #: (904) 692-2676

ACCESS EASEMENT EXHIBIT B

A PORTION OF SECTION 20, TOWNSHIP 6 SOUTH, RANGE 30 EAST, ST. JOHNS COUNTY, FLORIDA AND BEING MORE PARTICULARLY DESCRIBED AS FOLLOWS: FOR A POINT OF REFERENCE COMMENCE AT THE SOUTHWEST CORNER OF SAID SECTION 20, THENCE NORTH 07°45'00" WEST, ALONG THE WEST LINE OF SAID SECTION 20, 1486.69 FEET TO THE SOUTHWEST CORNER OF SAID SECTION 20, THENCE NORTH 07°45'00" WEST, ALONG THE WEST LINE OF SAID SECTION 20, 1486.69 FEET TO THE POINT OF BEGINNING. THENCE NORTH 83°53'30" EAST, 62.00 FEET, THENCE SOUTH 81°09'02" EAST, 1657.44 FEET, THENCE NORTH 34°53'30" WEST, 1218.19 FEET, THENCE NORTH 84°04'22" EAST, 68.04 FEET, THENCE SOUTH 81°09'02" EAST, 39.23 FEET, THENCE NORTH 76°23'00" WEST, 1424.49 FEET, THENCE SOUTH 07°55'17" WEST, 34.95 FEET, THENCE NORTH 82°40'46" WEST, 161.23 FEET, THENCE SOUTH 47°02'28" EAST, 80.65 FEET, THENCE SOUTH 44°00'23" WEST, 128.86 FEET, THENCE SOUTH 32°45'00" WEST, 1034.34 FEET, THENCE SOUTH 34°53'37" EAST, 1725.51 FEET, THENCE SOUTH 16°29'56" EAST, 53.83 FEET, THENCE SOUTH 05°10'17" WEST, 45.11 FEET, THENCE NORTH 10°38' FEET, THENCE SOUTH 18°31'11" EAST, 28.91 FEET, THENCE SOUTH 15°04'10" WEST, 153.71 FEET TO THE POINT OF BEGINNING. IN A SOUTHWESTERLY DIRECTION, ALONG THE ARC OF A CURVE, SAID CURVE BEING CONVEX SOUTHWESTERLY AND HAVING A RADIUS OF 1132.30 FEET, A CHORD BEARING AND DISTANCE OF SOUTH 36°20'27" EAST, 52.80 FEET, THENCE SOUTH 02°15'07" WEST, 50.42 FEET, THENCE SOUTH 11°37'07" WEST, 52.80 FEET, THENCE SOUTH 07°55'17" WEST, 34.95 FEET TO THE POINT OF BEGINNING.

LEGAL DESCRIPTION OF BUFFER AREA "A":

A PORTION OF SECTION 19 AND 20, TOWNSHIP 6 SOUTH, RANGE 30 EAST, ST. JOHNS COUNTY, FLORIDA AND BEING MORE PARTICULARLY DESCRIBED AS FOLLOWS: FOR A POINT OF REFERENCE COMMENCE AT THE SOUTHWEST CORNER OF SAID SECTION 20, THENCE NORTH 07°45'00" WEST, ALONG THE WESTERLY LINE OF SAID SECTION 20, 1486.69 FEET, THENCE NORTH 06°06'30" WEST, 89.28 FEET, THENCE NORTH 83°53'30" EAST, 62.00 FEET, THENCE SOUTH 81°09'02" EAST, 1657.44 FEET, THENCE NORTH 34°53'30" WEST, 1218.19 FEET, THENCE NORTH 84°04'22" EAST, 68.04 FEET, THENCE SOUTH 81°09'02" EAST, 39.23 FEET, THENCE NORTH 76°23'00" WEST, 1424.49 FEET, THENCE SOUTH 07°55'17" WEST, 34.95 FEET, THENCE NORTH 82°40'46" WEST, 161.23 FEET, THENCE SOUTH 47°02'28" EAST, 80.65 FEET, THENCE SOUTH 44°00'23" WEST, 128.86 FEET, THENCE SOUTH 32°45'00" WEST, 1034.34 FEET, THENCE SOUTH 34°53'37" EAST, 1725.51 FEET, THENCE SOUTH 16°29'56" EAST, 53.83 FEET, THENCE SOUTH 05°10'17" WEST, 45.11 FEET, THENCE NORTH 10°38' FEET, THENCE SOUTH 18°31'11" EAST, 28.91 FEET, THENCE SOUTH 15°04'10" WEST, 153.71 FEET TO THE POINT OF BEGINNING. IN A SOUTHWESTERLY DIRECTION, ALONG THE ARC OF A CURVE, SAID CURVE BEING CONVEX SOUTHWESTERLY AND HAVING A RADIUS OF 1132.30 FEET, A CHORD BEARING AND DISTANCE OF SOUTH 36°20'27" EAST, 52.80 FEET, THENCE SOUTH 02°15'07" WEST, 50.42 FEET, THENCE SOUTH 11°37'07" WEST, 52.80 FEET, THENCE SOUTH 07°55'17" WEST, 34.95 FEET TO THE POINT OF BEGINNING.

LINE CHART BUFFER AREA "A"

LINE	BEARING	DISTANCE
1	N 83°53'30" E	62.00
2	S 81°09'02" E	1657.44
3	N 34°53'30" W	1218.19
4	N 84°04'22" E	68.04
5	S 81°09'02" E	39.23
6	N 76°23'00" W	1424.49
7	S 07°55'17" W	34.95
8	N 82°40'46" W	161.23
9	S 47°02'28" E	80.65
10	S 44°00'23" W	128.86
11	S 32°45'00" W	1034.34
12	S 34°53'37" E	1725.51
13	S 16°29'56" E	53.83
14	S 05°10'17" W	45.11
15	N 10°38'00" E	28.91
16	S 18°31'11" W	153.71
17	S 15°04'10" W	153.71
18	S 36°20'27" E	52.80
19	S 02°15'07" W	50.42
20	S 11°37'07" W	52.80
21	S 07°55'17" W	34.95

CURVE CHART BUFFER AREA "A"

CURVE	RADIUS	ARC LENGTH	CHORD LENGTH	CHORD BEARING	DELTA ANGLE
01	2500'	16.20'	39.80'	S 01°41'55" W	105°52'45"
02	2500'	45.75'	39.80'	S 01°41'55" W	105°52'45"
03	2500'	45.87'	39.58'	S 48°03'51" W	104°10'18"

AS-BUILT  
 DATE: 4-1-02  
 DRAWN BY: MTD  
 CHECKED BY: MTD  
 SCALE: 1"=40'  
 PROJECT NO.: 09-03-101

OCEAN GRANDE  
AT SERENATA BEACH,  
A CONDOMINIUM

COPY

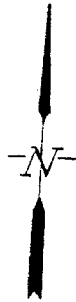
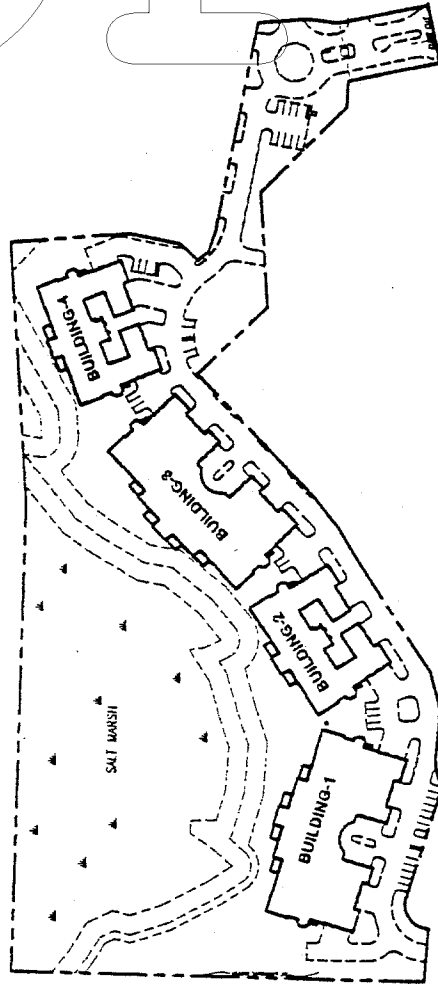

100 0 100 200  
SCALE: 1:200

Phase I  
Site Plan

COPY

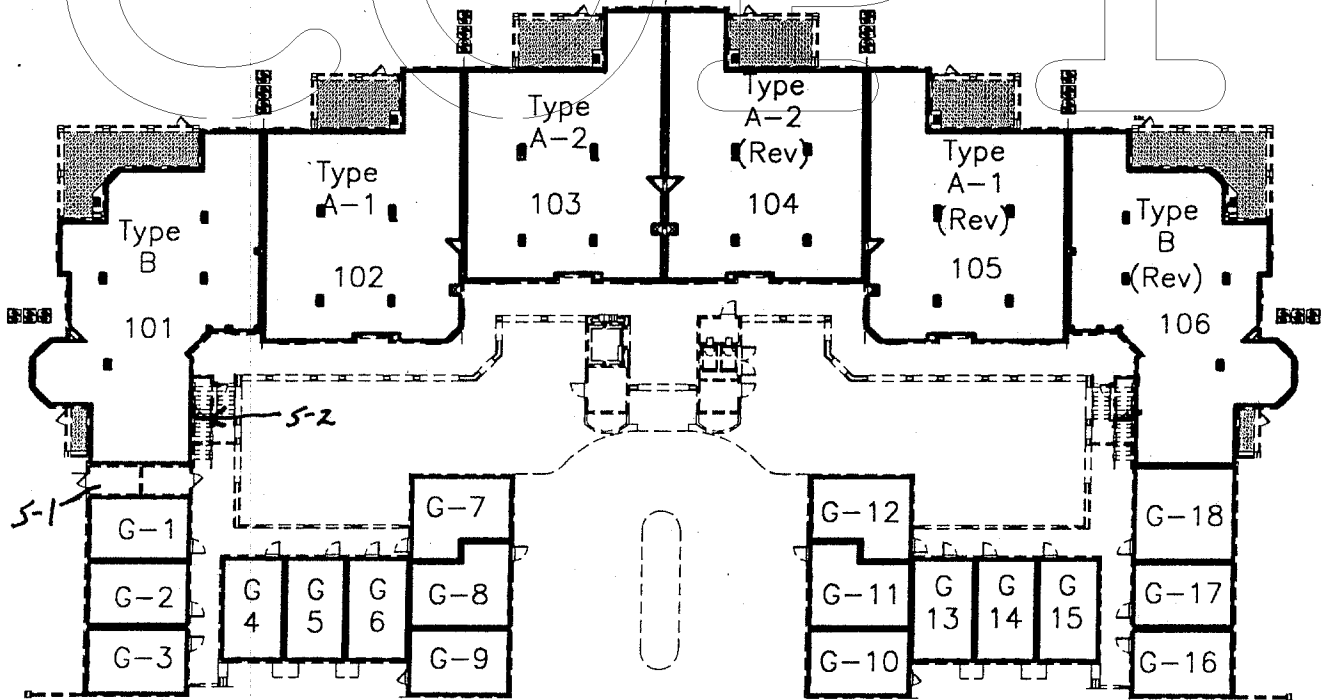

LEGEND:

- CONDOMINIUM UNIT BOUNDARY LINE
- - - COMMON ELEMENT BOUNDARY LINE
- ▨ LIMITED COMMON ELEMENT

NOTES:

Each Condominium Unit consists of the space bounded by the Condominium Unit boundary lines by:  
 (a) Upper Boundaries. The horizontal plane of the unfinished lower surface of the structural ceiling of the unit.  
 (b) Lower Boundaries. The horizontal plane of the unfinished upper surface of the concrete floor of the unit.  
 (c) Perimeter Boundary. The perimeter boundary of the unit shall be the vertical planes of the unfinished interior surfaces of the wall bounding the unit extended to their planar intersections with each other and with the upper and lower boundaries.

There may exist some variation between the proposed improvements and the improvements as constructed.

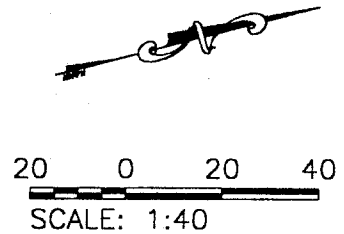

**Building 1  
(1st Floor)**

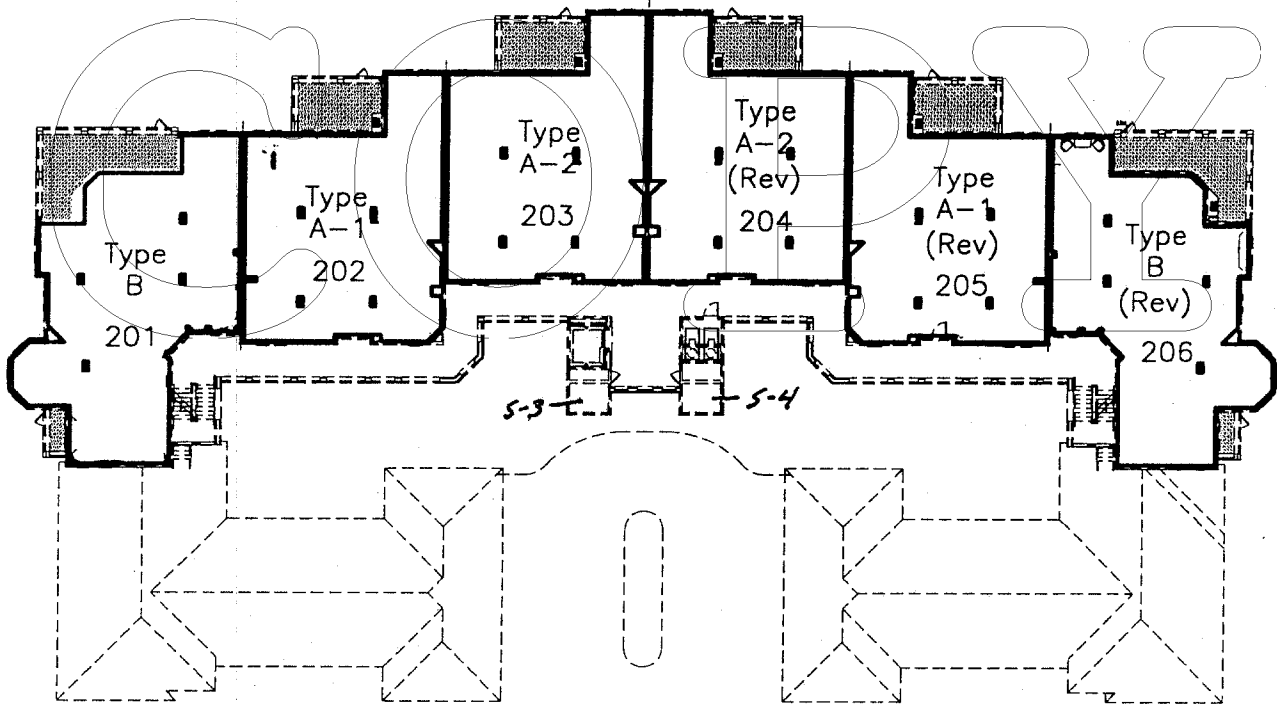

LEGEND:

- CONDOMINIUM UNIT BOUNDARY LINE
- - - - COMMON ELEMENT BOUNDARY LINE
- ▨ LIMITED COMMON ELEMENT

NOTES:

Each Condominium Unit consists of the space bounded by the Condominium Unit boundary lines by:

- (a) Upper Boundaries. The horizontal plane of the unfinished lower surface of the structural ceiling of the unit.
- (b) Lower Boundaries. The horizontal plane of the unfinished upper surface of the concrete floor of the unit.
- (c) Perimeter Boundary. The perimeter boundary of the unit shall be the vertical planes of the unfinished interior surfaces of the wall bounding the unit extended to their planar intersections with each other and with the upper and lower boundaries.

There may exist some variation between the proposed improvements and the improvements as constructed.

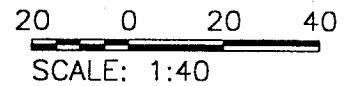

**Building 1  
(2nd Floor)**

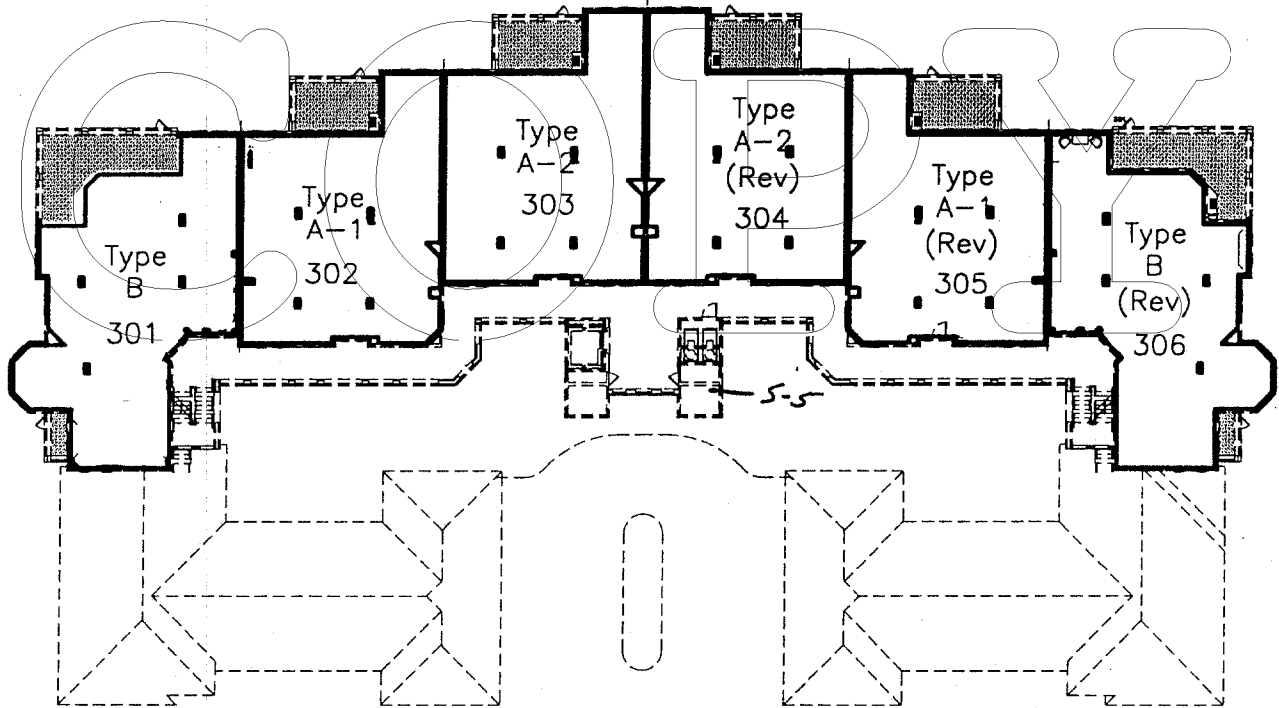

LEGEND:

- CONDOMINIUM UNIT BOUNDARY LINE
- - - COMMON ELEMENT BOUNDARY LINE
- ▨ LIMITED COMMON ELEMENT

NOTES:

Each Condominium Unit consists of the space bounded by the Condominium Unit boundary lines by:

- (a) Upper Boundaries. The horizontal plane of the unfinished lower surface of the structural ceiling of the unit.
- (b) Lower Boundaries. The horizontal plane of the unfinished upper surface of the concrete floor of the unit.
- (c) Perimeter Boundary. The perimeter boundary of the unit shall be the vertical planes of the unfinished interior surfaces of the wall bounding the unit extended to their planar intersections with each other and with the upper and lower boundaries.

There may exist some variation between the proposed improvements and the improvements as constructed.

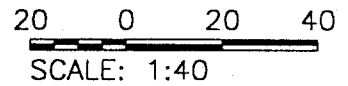

**Building 1  
(3rd Floor)**

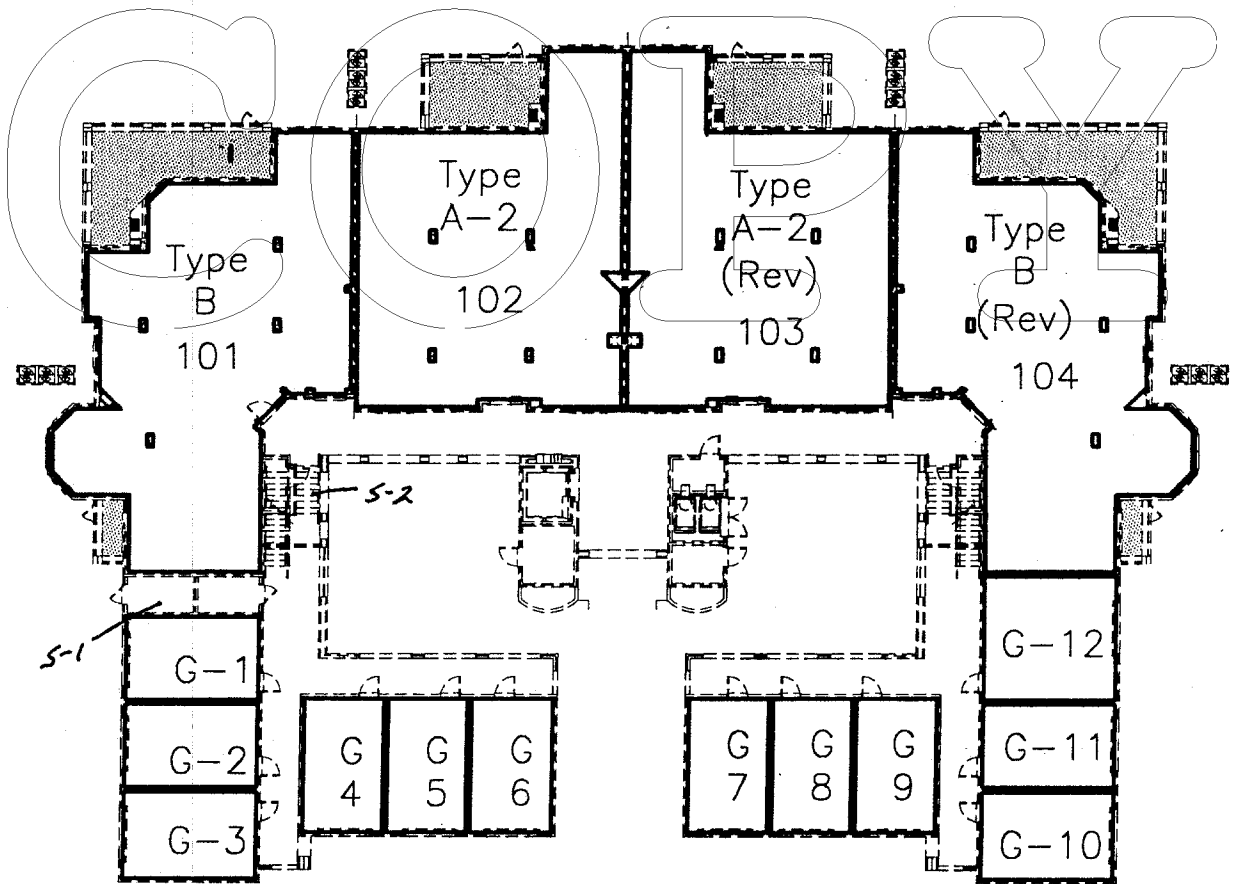

LEGEND:

- CONDOMINIUM UNIT BOUNDARY LINE
- - - - COMMON ELEMENT BOUNDARY LINE
- ▨ LIMITED COMMON ELEMENT

NOTES:

Each Condominium Unit consists of the space bounded by the Condominium Unit boundary lines by:  
 (a) Upper Boundaries. The horizontal plane of the unfinished lower surface of the structural ceiling of the unit.  
 (b) Lower Boundaries. The horizontal plane of the unfinished upper surface of the concrete floor of the unit.  
 (c) Perimeter Boundary. The perimeter boundary of the unit shall be the vertical planes of the unfinished interior surfaces of the wall bounding the unit extended to their planar intersections with each other and with the upper and lower boundaries.

There may exist some variation between the proposed improvements and the improvements as constructed.

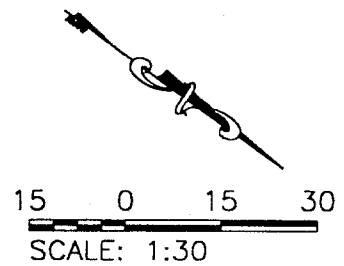

**Building 2  
(1st Floor)**

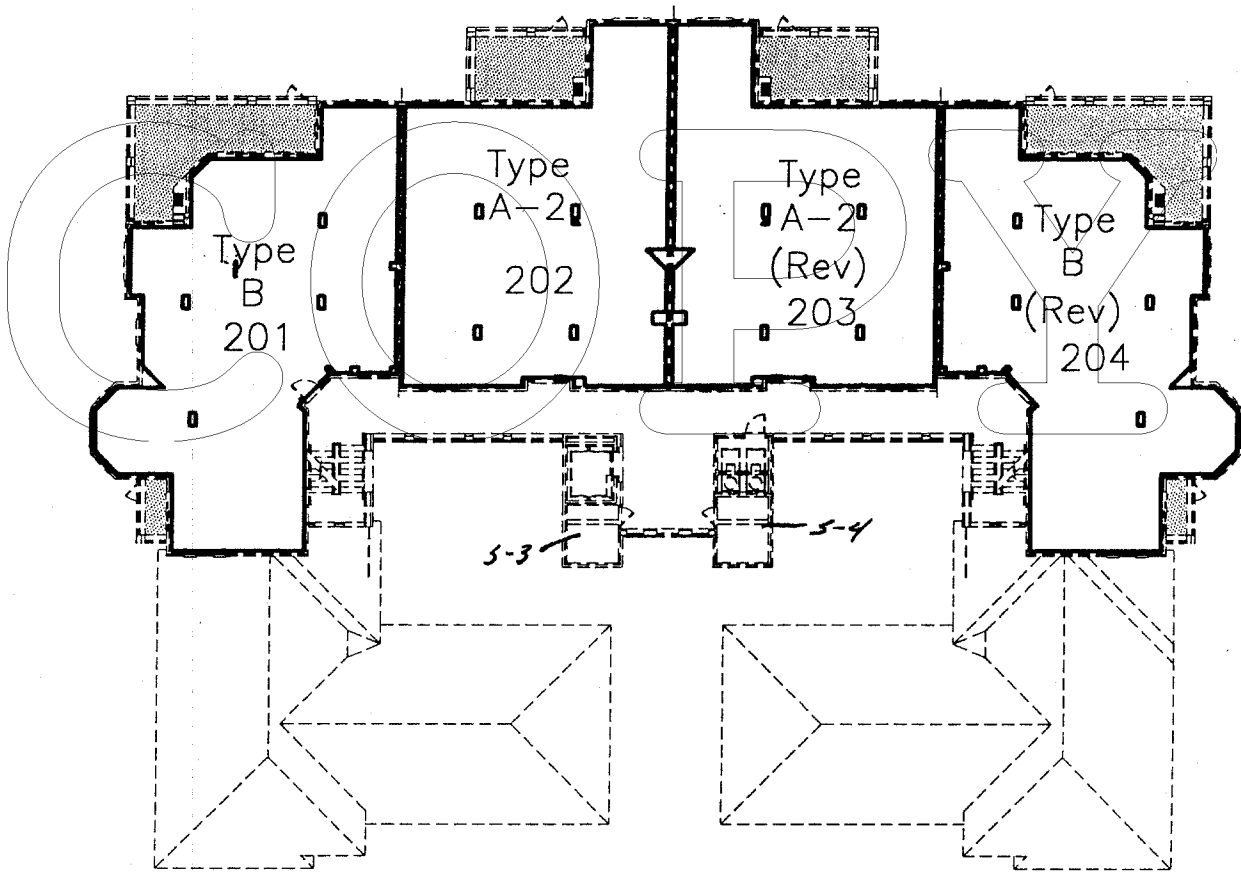

LEGEND:

- CONDOMINIUM UNIT BOUNDARY LINE
- - - COMMON ELEMENT BOUNDARY LINE
- ▨ LIMITED COMMON ELEMENT

NOTES:

Each Condominium Unit consists of the space bounded by the Condominium Unit boundary lines by:

- (a) Upper Boundaries. The horizontal plane of the unfinished lower surface of the structural ceiling of the unit.
- (b) Lower Boundaries. The horizontal plane of the unfinished upper surface of the concrete floor of the unit.
- (c) Perimeter Boundary. The perimeter boundary of the unit shall be the vertical planes of the unfinished interior surfaces of the wall bounding the unit extended to their planar intersections with each other and with the upper and lower boundaries.

There may exist some variation between the proposed improvements and the improvements as constructed.

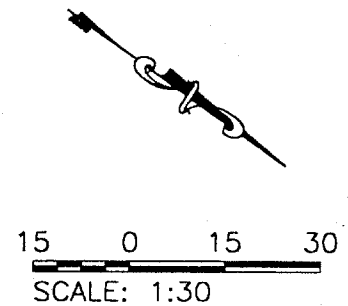

**Building 2  
(2nd Floor)**

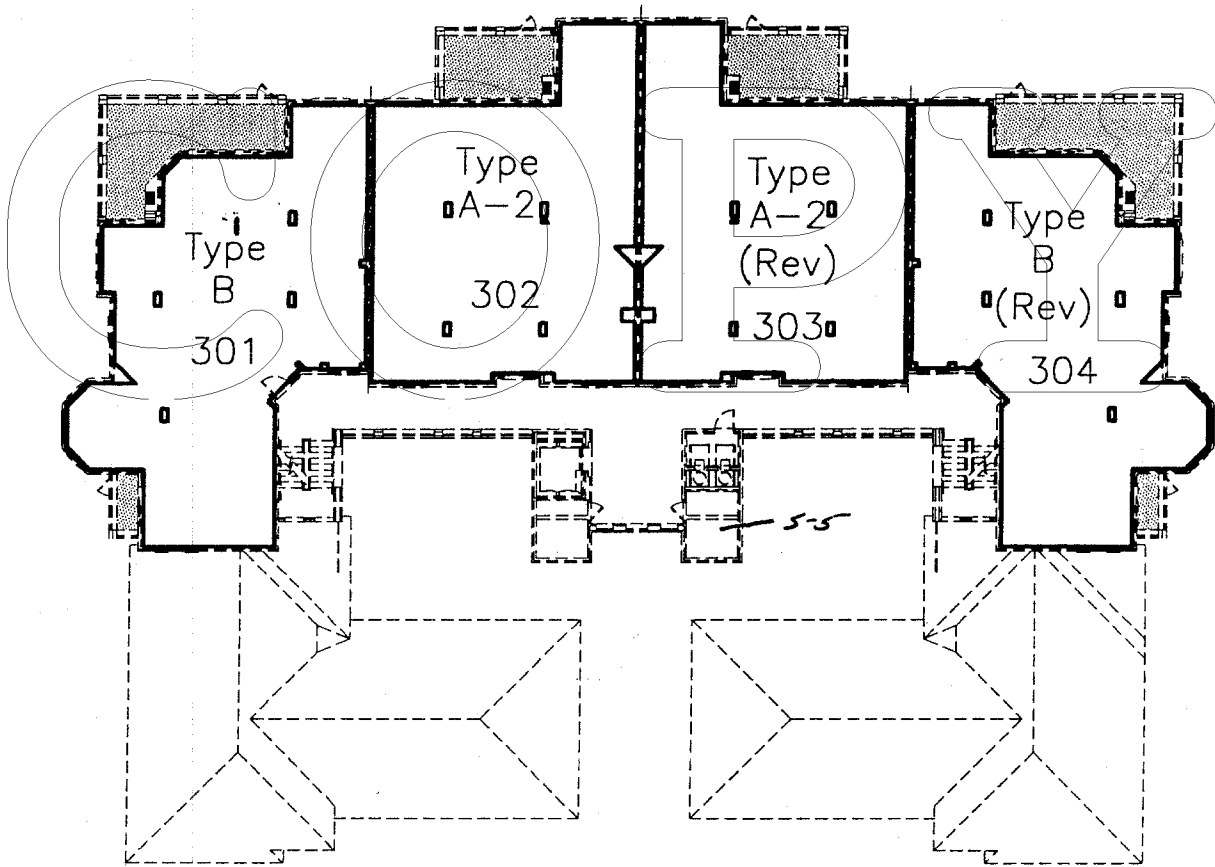

LEGEND:

- CONDOMINIUM UNIT BOUNDARY LINE
- - - - COMMON ELEMENT BOUNDARY LINE
- ▨ LIMITED COMMON ELEMENT

NOTES:

Each Condominium Unit consists of the space bounded by the Condominium Unit boundary lines by:

- (a) Upper Boundaries. The horizontal plane of the unfinished lower surface of the structural ceiling of the unit.
- (b) Lower Boundaries. The horizontal plane of the unfinished upper surface of the concrete floor of the unit.
- (c) Perimeter Boundary. The perimeter boundary of the unit shall be the vertical planes of the unfinished interior surfaces of the wall bounding the unit extended to their planar intersections with each other and with the upper and lower boundaries.

There may exist some variation between the proposed improvements and the improvements as constructed.

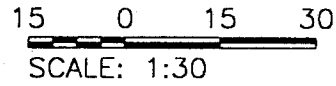
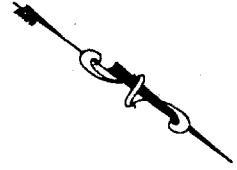

**Building 2  
(3rd Floor)**



COPY

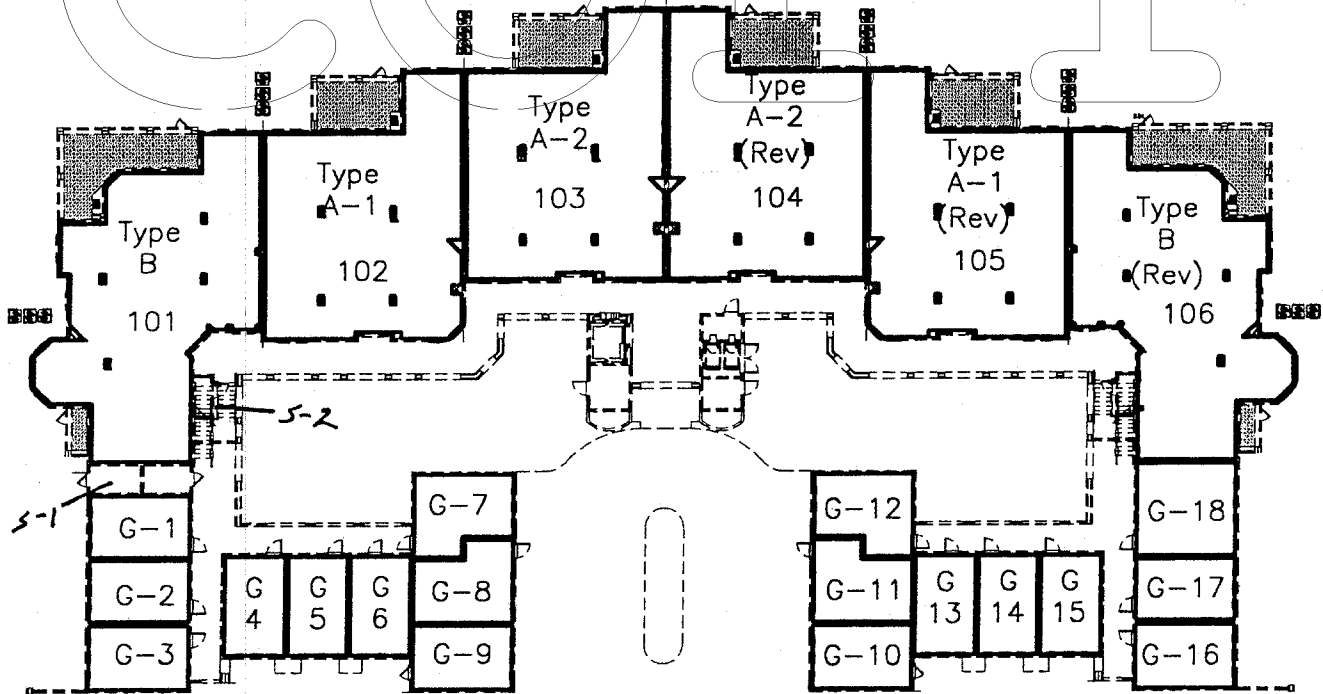

LEGEND:

- CONDOMINIUM UNIT BOUNDARY LINE
- - - COMMON ELEMENT BOUNDARY LINE
- ▨ LIMITED COMMON ELEMENT

NOTES:

Each Condominium Unit consists of the space bounded by the Condominium Unit boundary lines by:  
 (a) Upper Boundaries. The horizontal plane of the unfinished lower surface of the structural ceiling of the unit.  
 (b) Lower Boundaries. The horizontal plane of the unfinished upper surface of the concrete floor of the unit.  
 (c) Perimeter Boundary. The perimeter boundary of the unit shall be the vertical planes of the unfinished interior surfaces of the wall bounding the unit extended to their planar intersections with each other and with the upper and lower boundaries.

There may exist some variation between the proposed improvements and the improvements as constructed.

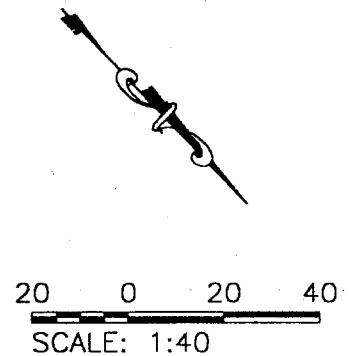

**Building 3  
(1st Floor)**

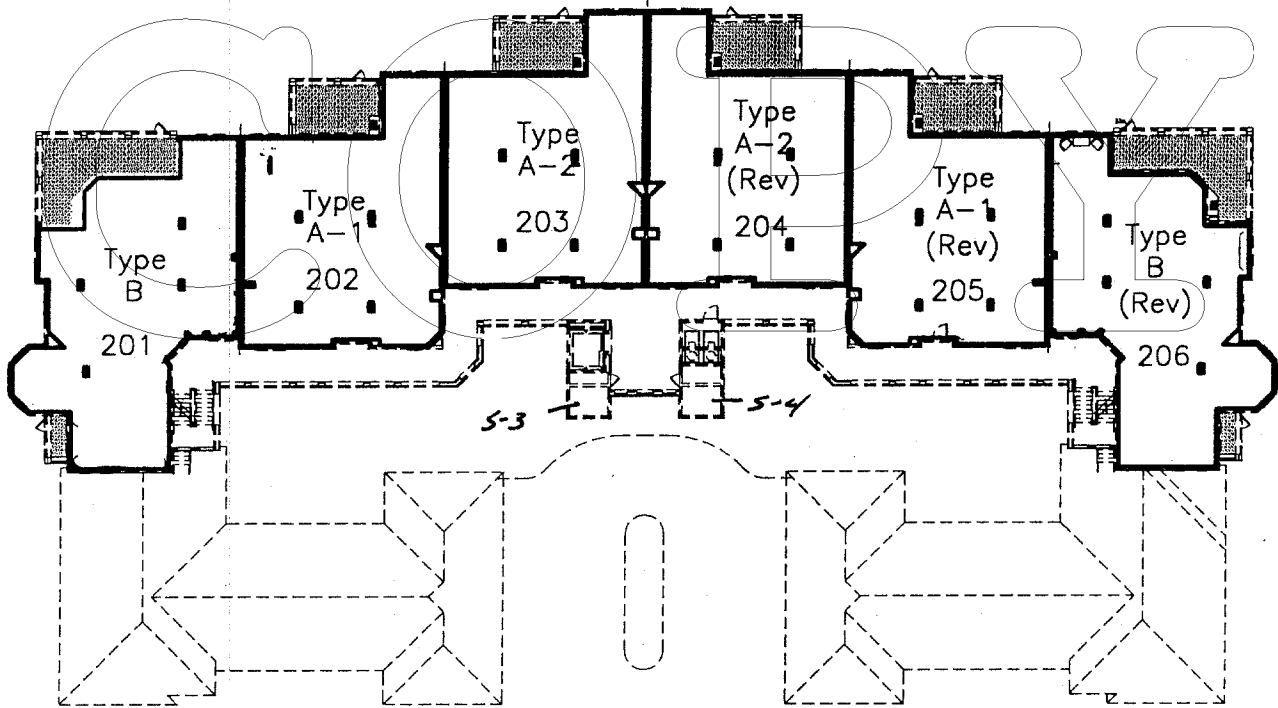

LEGEND:

- CONDOMINIUM UNIT BOUNDARY LINE
- - - COMMON ELEMENT BOUNDARY LINE
- ▨ LIMITED COMMON ELEMENT

NOTES:

Each Condominium Unit consists of the space bounded by the Condominium Unit boundary lines by:

- (a) Upper Boundaries. The horizontal plane of the unfinished lower surface of the structural ceiling of the unit.
- (b) Lower Boundaries. The horizontal plane of the unfinished upper surface of the concrete floor of the unit.
- (c) Perimeter Boundary. The perimeter boundary of the unit shall be the vertical planes of the unfinished interior surfaces of the wall bounding the unit extended to their planar intersections with each other and with the upper and lower boundaries.

There may exist some variation between the proposed improvements and the improvements as constructed.

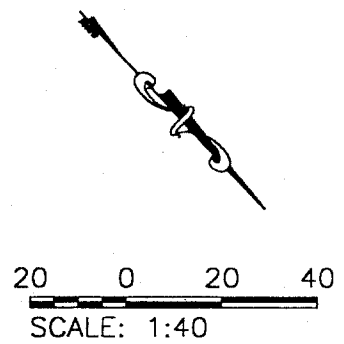

**Building 3  
(2nd Floor)**

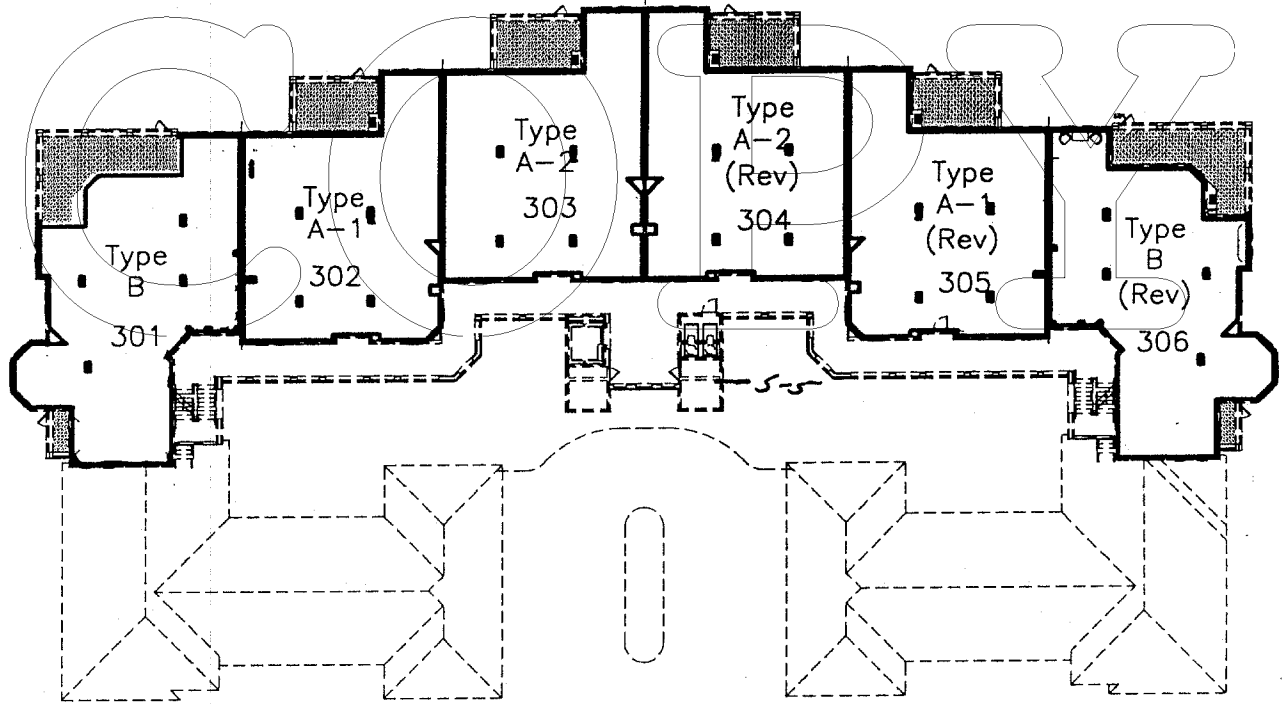

LEGEND:

- CONDOMINIUM UNIT BOUNDARY LINE
- - - COMMON ELEMENT BOUNDARY LINE
- ▨ LIMITED COMMON ELEMENT

NOTES:

Each Condominium Unit consists of the space bounded by the Condominium Unit boundary lines by:

- (a) Upper Boundaries. The horizontal plane of the unfinished lower surface of the structural ceiling of the unit.
- (b) Lower Boundaries. The horizontal plane of the unfinished upper surface of the concrete floor of the unit.
- (c) Perimeter Boundary. The perimeter boundary of the unit shall be the vertical planes of the unfinished interior surfaces of the wall bounding the unit extended to their planar intersections with each other and with the upper and lower boundaries.

There may exist some variation between the proposed improvements and the improvements as constructed.

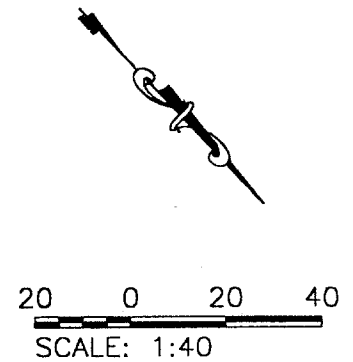

**Building 3  
(3rd Floor)**

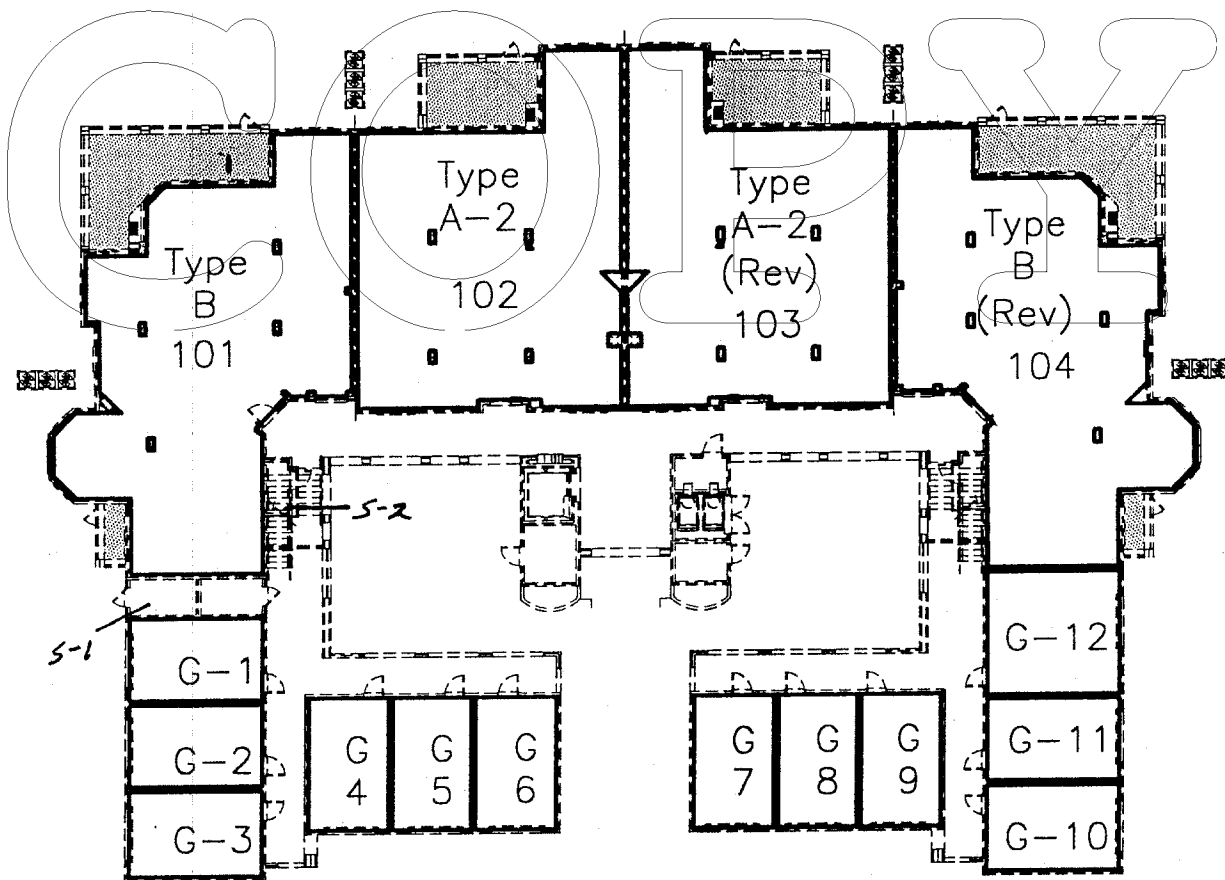

LEGEND:

- CONDOMINIUM UNIT BOUNDARY LINE
- - - - COMMON ELEMENT BOUNDARY LINE
- ▨ LIMITED COMMON ELEMENT

NOTES:

Each Condominium Unit consists of the space bounded by the Condominium Unit boundary lines by:

- (a) Upper Boundaries. The horizontal plane of the unfinished lower surface of the structural ceiling of the unit.
- (b) Lower Boundaries. The horizontal plane of the unfinished upper surface of the concrete floor of the unit.
- (c) Perimeter Boundary. The perimeter boundary of the unit shall be the vertical planes of the unfinished interior surfaces of the wall bounding the unit extended to their planar intersections with each other and with the upper and lower boundaries.

There may exist some variation between the proposed improvements and the improvements as constructed.

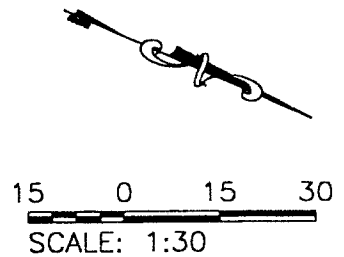

**Building 4  
(1st Floor)**

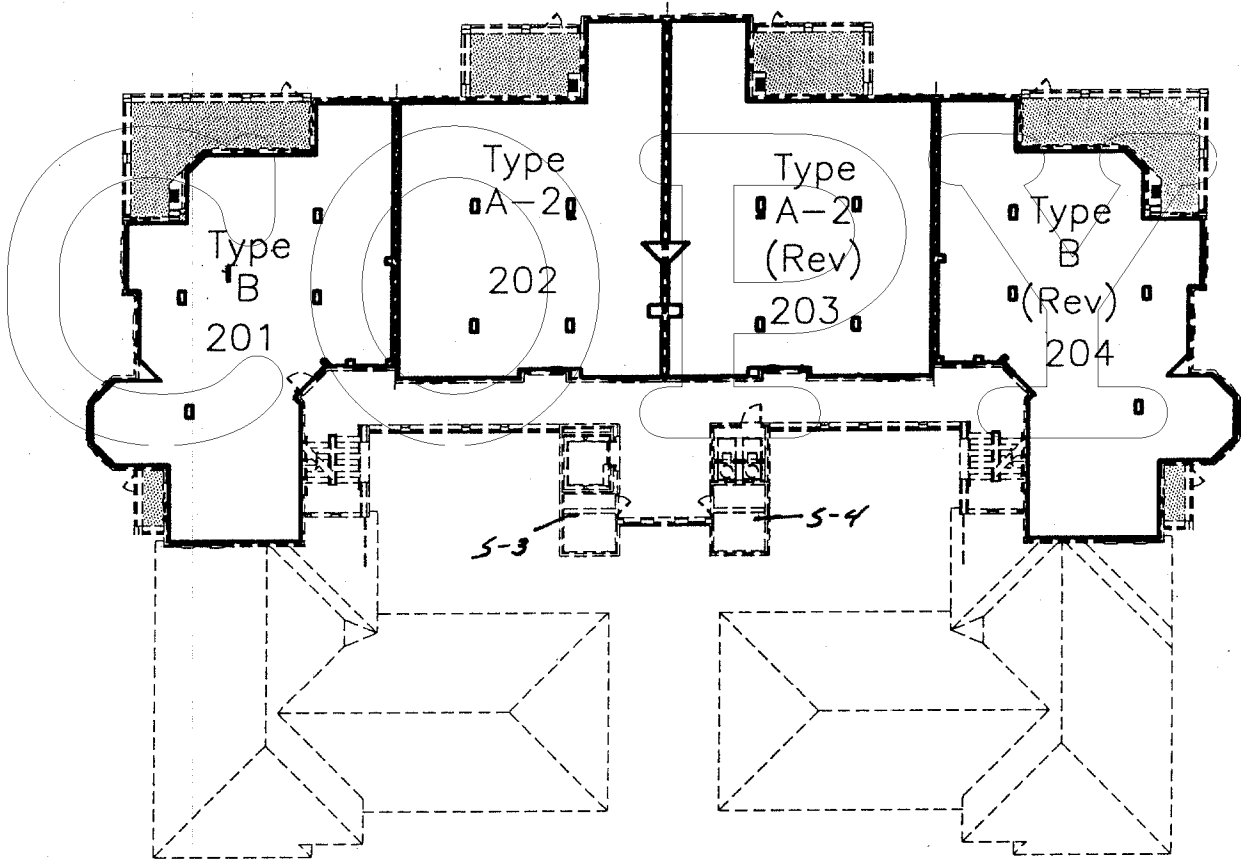

LEGEND:

- CONDOMINIUM UNIT BOUNDARY LINE
- - - COMMON ELEMENT BOUNDARY LINE
- ▨ LIMITED COMMON ELEMENT

NOTES:

Each Condominium Unit consists of the space bounded by the Condominium Unit boundary lines by:

- (a) Upper Boundaries. The horizontal plane of the unfinished lower surface of the structural ceiling of the unit.
- (b) Lower Boundaries. The horizontal plane of the unfinished upper surface of the concrete floor of the unit.
- (c) Perimeter Boundary. The perimeter boundary of the unit shall be the vertical planes of the unfinished interior surfaces of the wall bounding the unit extended to their planar intersections with each other and with the upper and lower boundaries.

There may exist some variation between the proposed improvements and the improvements as constructed.

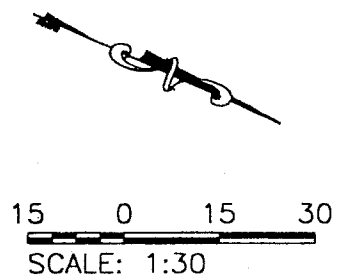

**Building 4  
(2nd Floor)**

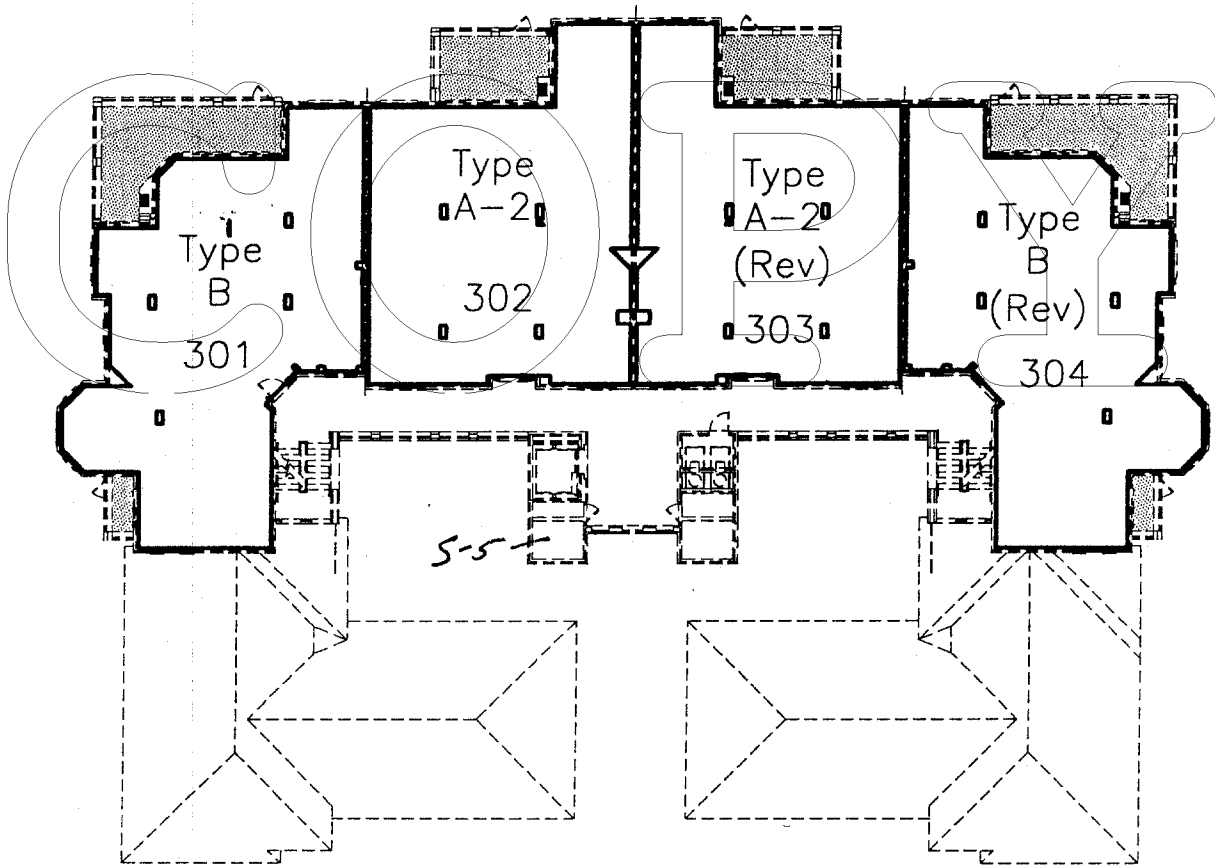

LEGEND:

- CONDOMINIUM UNIT BOUNDARY LINE
- - - COMMON ELEMENT BOUNDARY LINE
- ▨ LIMITED COMMON ELEMENT

NOTES:

Each Condominium Unit consists of the space bounded by the Condominium Unit boundary lines by:

- (a) Upper Boundaries. The horizontal plane of the unfinished lower surface of the structural ceiling of the unit.
- (b) Lower Boundaries. The horizontal plane of the unfinished upper surface of the concrete floor of the unit.
- (c) Perimeter Boundary. The perimeter boundary of the unit shall be the vertical planes of the unfinished interior surfaces of the wall bounding the unit extended to their planar intersections with each other and with the upper and lower boundaries.

There may exist some variation between the proposed improvements and the improvements as constructed.

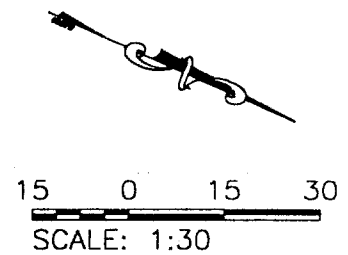

**Building 4  
(3rd Floor)**

# OCEAN GRANDE AT SERENATA BEACH, A CONDOMINIUM

COPY

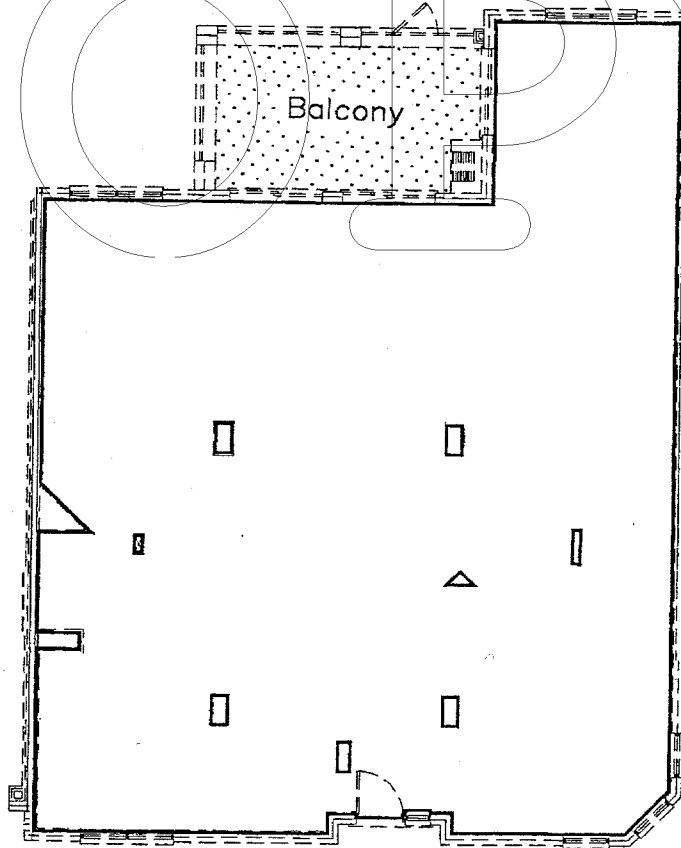

Unit:  
Building 1&3:  
102 thru 302

**LEGEND:**

- CONDOMINIUM UNIT BOUNDARY LINE
- - - - COMMON ELEMENT BOUNDARY LINE
- ..... LIMITED COMMON ELEMENT

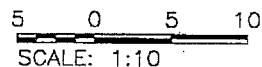

**NOTES:**

- Each Condominium Unit consists of the space bounded by the Condominium Unit boundary lines by:
- (a) Upper Boundaries. The horizontal planes of the unfinished lower surface of the structural ceiling of the unit.
  - (b) Lower Boundaries. The horizontal plane of the unfinished upper surface of the concrete floor of the unit.
  - (c) Perimeter Boundary. The perimeter boundary of the unit shall be the vertical planes of the unfinished interior surfaces of the wall bounding the unit extended to their planar intersections with each other and with the upper and lower boundaries.

There may exist some variation between the proposed improvements and the Improvements as constructed.

OCEAN GRANDE  
AT SERENATA BEACH,  
A CONDOMINIUM

COPY

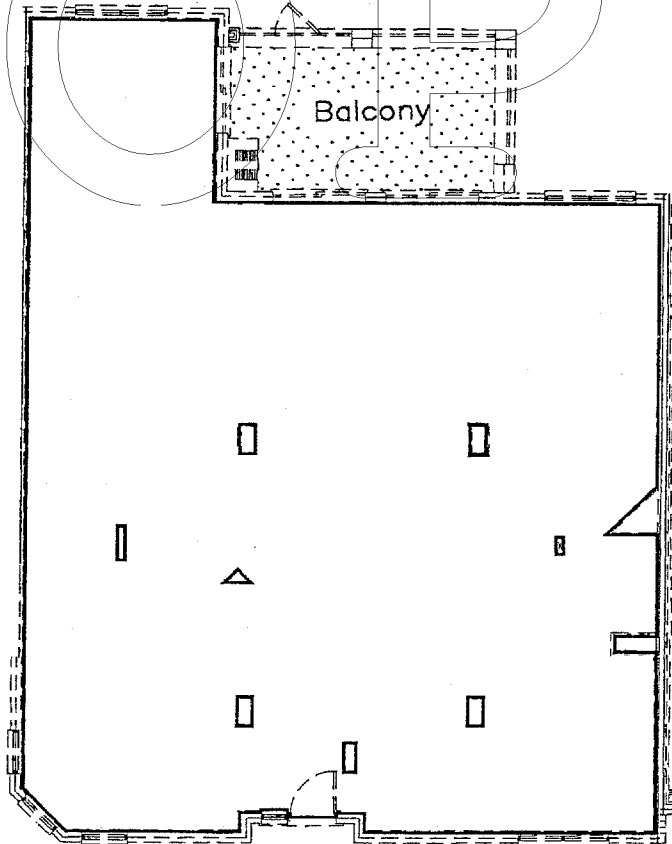

Unit:  
Building 1&3:  
102 thru 302

LEGEND:

- CONDOMINIUM UNIT BOUNDARY LINE
- - - COMMON ELEMENT BOUNDARY LINE
- ▒ LIMITED COMMON ELEMENT

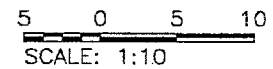

NOTES:

Each Condominium Unit consists of the space bounded by the Condominium Unit boundary lines by:  
 (a) Upper Boundaries. The horizontal plane of the unfinished lower surface of the structural ceiling of the unit.  
 (b) Lower Boundaries. The horizontal plane of the unfinished upper surface of the concrete floor of the unit.  
 (c) Perimeter Boundary. The perimeter boundary of the unit shall be the vertical planes of the unfinished interior surfaces of the wall bounding the unit extended to their planar intersections with each other and with the upper and lower boundaries.

There may exist some variation between the proposed improvements and the improvements as constructed.



OCEAN GRANDE  
AT SERENATA BEACH,  
A CONDOMINIUM

COPY

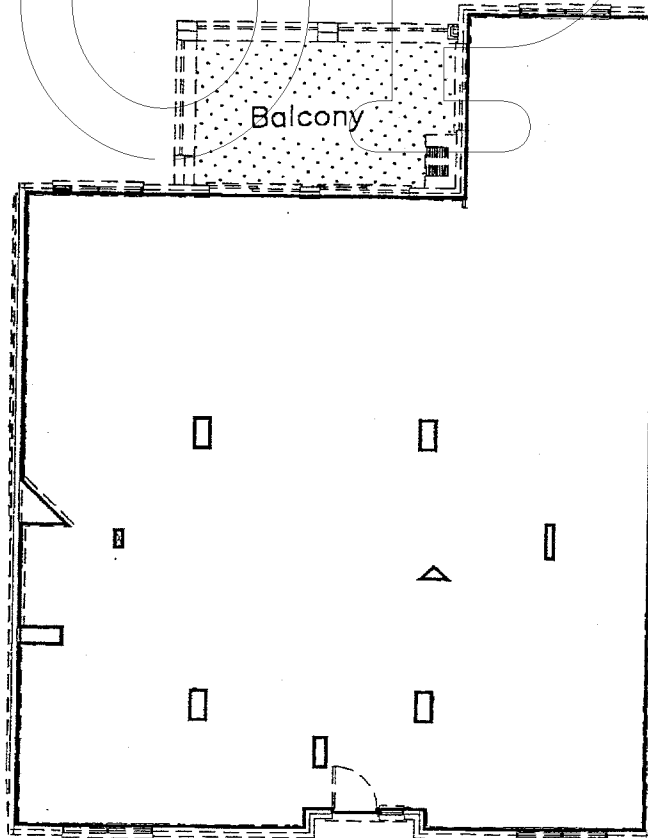

Unit:  
Building 1 & 3:  
103 thru 303  
  
Building 2 & 4:  
102 thru 302

LEGEND:

- CONDOMINIUM UNIT BOUNDARY LINE
- - - - COMMON ELEMENT BOUNDARY LINE
- ..... LIMITED COMMON ELEMENT

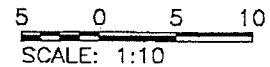

NOTES:

Each Condominium Unit consists of the space bounded by the Condominium Unit boundary lines by:  
 (a) Upper Boundaries. The horizontal planes of the unfinished lower surface of the structural ceiling of the unit.  
 (b) Lower Boundaries. The horizontal plane of the unfinished upper surface of the concrete floor of the unit.  
 (c) Perimeter Boundary. The perimeter boundary of the unit shall be the vertical planes of the unfinished interior surfaces of the wall bounding the unit extended to their planar intersections with each other and with the upper and lower boundaries.

There may exist some variation between the proposed improvements and the improvements as constructed.

# OCEAN GRANDE AT SERENATA BEACH, A CONDOMINIUM

COPY

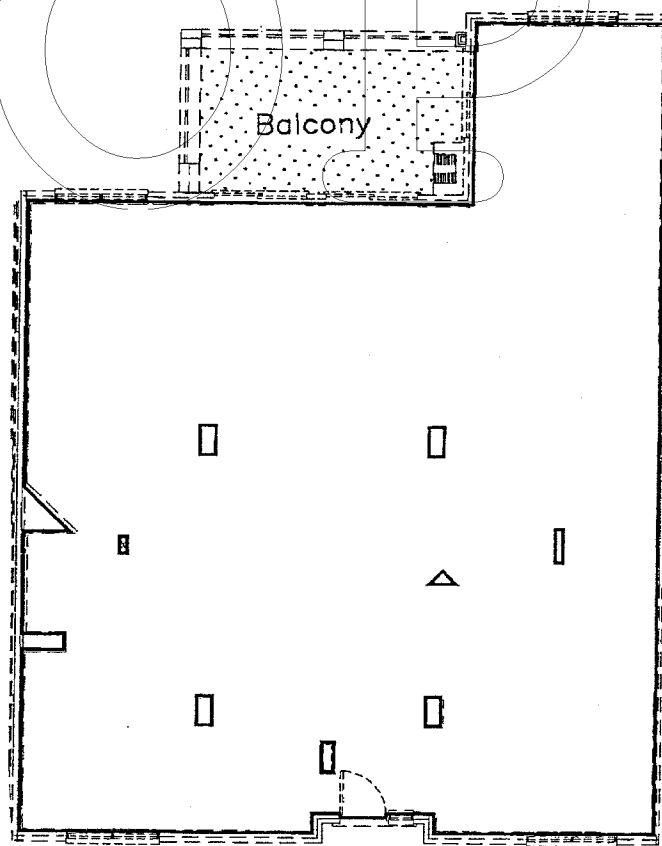

Unit:  
 Building 1 & 3:  
 104 thru 304  
 Building 2 & 4:  
 103 thru 303

**LEGEND:**

- CONDOMINIUM UNIT BOUNDARY LINE
- - - - COMMON ELEMENT BOUNDARY LINE
- ..... LIMITED COMMON ELEMENT

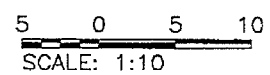

**NOTES:**

Each Condominium Unit consists of the space bounded by the Condominium Unit boundary lines by:  
 (a) Upper Boundaries. The horizontal plane of the unfinished lower surface of the structural ceiling of the unit.  
 (b) Lower Boundaries. The horizontal plane of the unfinished upper surface of the concrete floor of the unit.  
 (c) Perimeter Boundary. The perimeter boundary of the unit shall be the vertical planes of the unfinished interior surfaces of the wall bounding the unit extended to their planar intersections with each other and with the upper and lower boundaries.

There may exist some variation between the proposed improvements and the improvements as constructed.

# OCEAN GRANDE AT SERENATA BEACH, A CONDOMINIUM

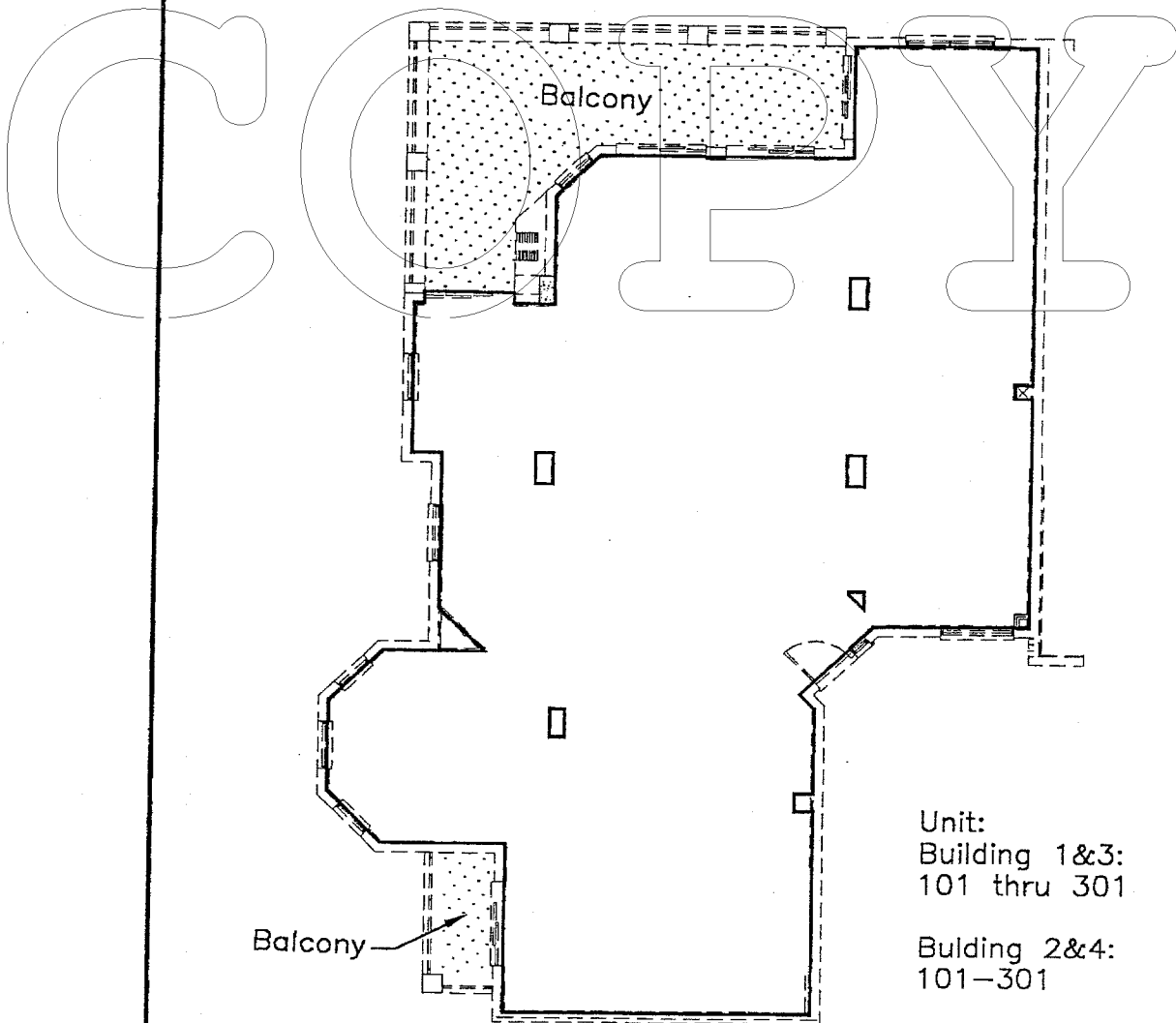

Unit:  
Building 1&3:  
101 thru 301  
  
Building 2&4:  
101-301

**LEGEND:**

- CONDOMINIUM UNIT BOUNDARY LINE
- - - - COMMON ELEMENT BOUNDARY LINE
- ..... LIMITED COMMON ELEMENT

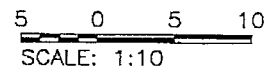

**NOTES:**

Each Condominium Unit consists of the space bounded by the Condominium Unit boundary lines by:  
 (a) Upper Boundaries. The horizontal planes of the unfinished lower surface of the structural ceiling of the unit.  
 (b) Lower Boundaries. The horizontal plane of the unfinished upper surface of the concrete floor of the unit.  
 (c) Perimeter Boundary. The perimeter boundary of the unit shall be the vertical planes of the unfinished interior surfaces of the wall bounding the unit extended to their planar intersections with each other and with the upper and lower boundaries.

There may exist some variation between the proposed improvements and the improvements as constructed.

# OCEAN GRANDE AT SERENATA BEACH, A CONDOMINIUM

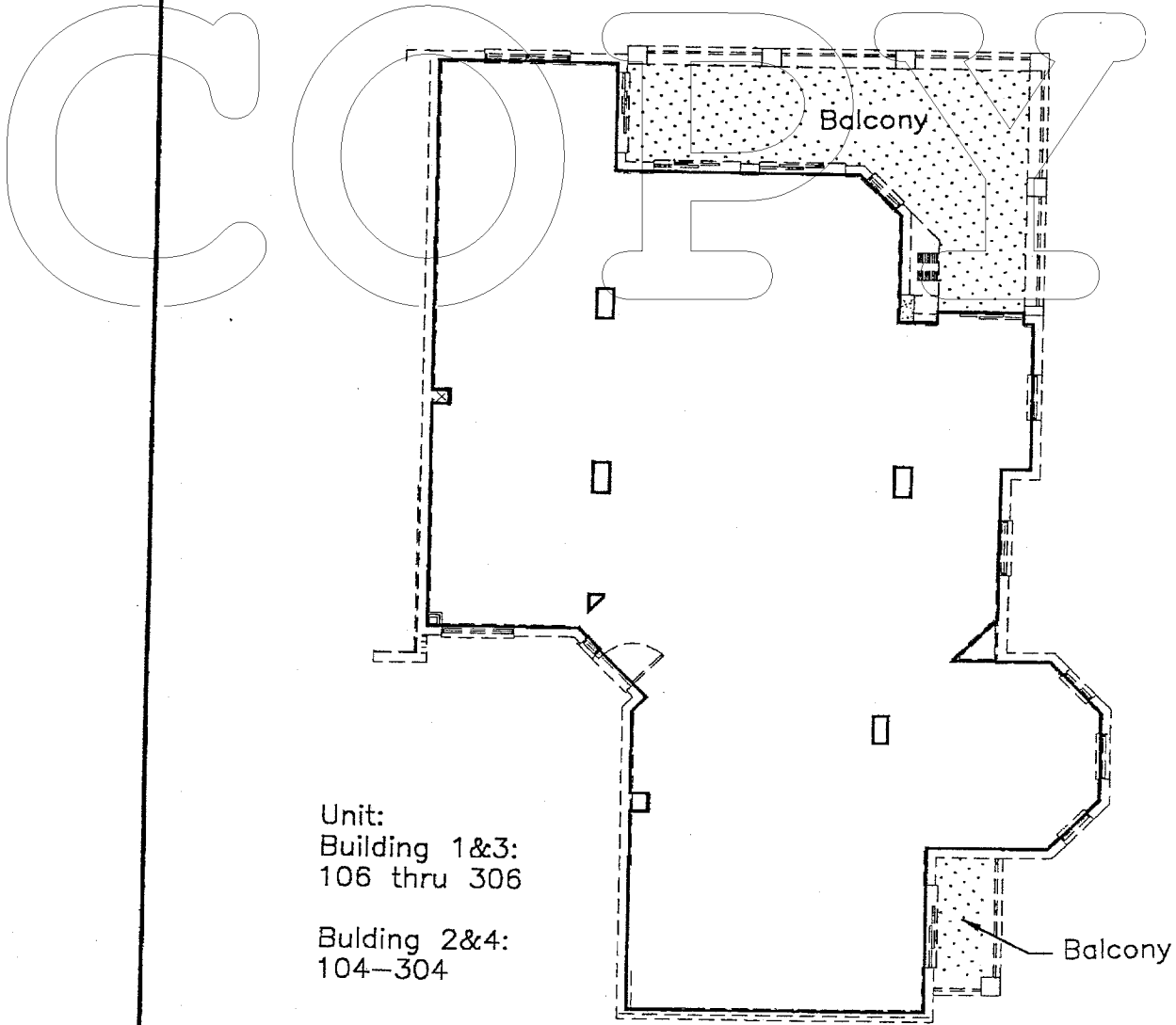

Unit:  
Building 1&3:  
106 thru 306

Bulding 2&4:  
104-304

**LEGEND:**

- CONDOMINIUM UNIT BOUNDARY LINE
- - - - COMMON ELEMENT BOUNDARY LINE
- ..... LIMITED COMMON ELEMENT

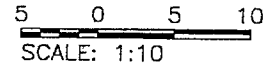

**NOTES:**

Each Condominium Unit consists of the space bounded by the Condominium Unit boundary lines by:  
 (a) Upper Boundaries. The horizontal plane of the unfinished lower surface of the structural ceiling of the unit.  
 (b) Lower Boundaries. The horizontal plane of the unfinished upper surface of the concrete floor of the unit.  
 (c) Perimeter Boundary. The perimeter boundary of the unit shall be the vertical planes of the unfinished interior surfaces of the wall bounding the unit extended to their planar intersections with each other and with the upper and lower boundaries.

There may exist some variation between the proposed improvements and the improvements as constructed.

OCEAN GRANDE  
AT SERENATA BEACH,  
A CONDOMINIUM

COPY

ROOF 35'-0"

LEVEL-3 20'-0"  
TOP OF SLAB

LEVEL-2 10'-0"  
TOP OF SLAB

LEVEL-1 0'-0"  
FIN. FLR.

Elevation  
BUILDINGS 1,2,3 & 4.

OCEAN GRANDE  
AT SERENATA BEACH,  
A CONDOMINIUM

COPY

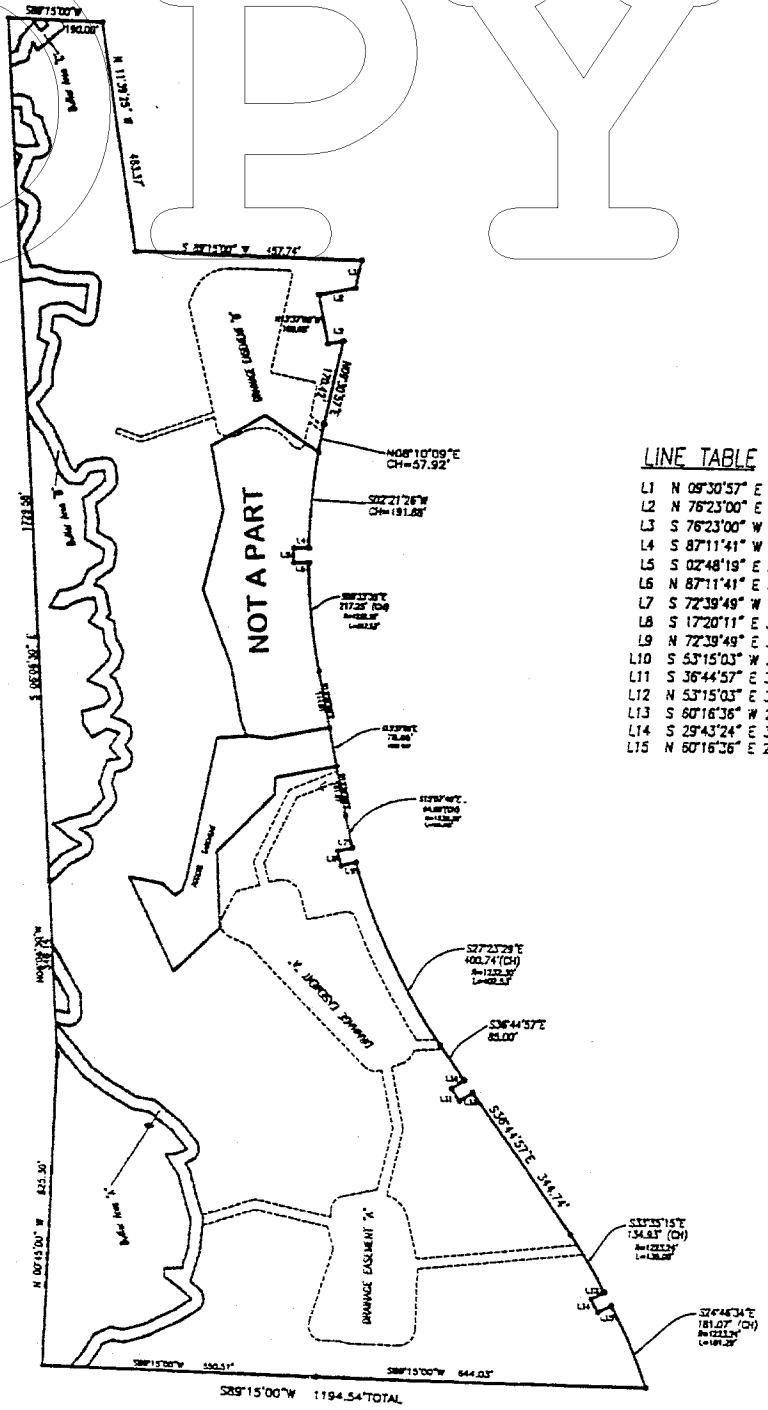

**LINE TABLE**

L1	N 09°30'37" E	56.56'
L2	N 76°23'00" E	73.51'
L3	S 76°23'00" W	30.79'
L4	S 87°11'41" W	30.09'
L5	S 02°48'19" E	30.00'
L6	N 87°11'41" E	30.09'
L7	S 72°39'49" W	30.09'
L8	S 17°20'11" E	30.00'
L9	N 72°39'49" E	30.09'
L10	S 53°15'03" W	30.00'
L11	S 36°44'57" E	30.00'
L12	N 53°15'03" E	30.00'
L13	S 60°16'36" W	29.91'
L14	S 29°43'24" E	30.00'
L15	N 60°16'36" E	29.91'

150 0 150 300  
SCALE: 1:300

See sheets 8-14 for Drainage Easement, Buffer Area, and Access Easement Legal Descriptions.

Master  
Site Survey

## OCEAN GRANDE AT SERENATA BEACH, A CONDOMINIUM

A PORTION OF SECTIONS 19 AND 20, TOWNSHIP 6 SOUTH, RANGE 30 EAST, ST. JOHNS COUNTY, FLORIDA AND BEING MORE PARTICULARLY DESCRIBED AS FOLLOWS:

FOR A POINT OF REFERENCE COMMENCE AT AN OLD COQUINA MONUMENT FOUND AND LOCALLY ACCEPTED AS THE SOUTHWEST CORNER OF SAID SECTION 20; THENCE NORTH 00°45'00" WEST, ALONG THE WEST LINE OF SAID SECTION 20, AS FOUND MONUMENTED AND SHOWN ON VARIOUS OTHER SURVEYS, 1486.69 FEET TO THE POINT OF BEGINNING.

FROM THE POINT OF BEGINNING THUS DESCRIBED THENCE CONTINUE NORTH 00°45'00" WEST, ALONG SAID WEST LINE OF SECTION 20, THE SAME BEING THE WEST LINE OF LANDS DESCRIBED IN DEED RECORDED IN SAID OFFICIAL RECORDS IN BOOK 662, PAGE 270, 625.30 FEET TO A FOUND COQUINA MONUMENT; THENCE NORTH 06°06'30" WEST, ALONG THE WEST LINE OF LAST MENTIONED DEED, 2077.72 FEET TO A 1/2" IRON PIPE (STAMPED "LB 4238") FOUND AT A SOUTHERLY LINE OF LANDS DESCRIBED IN DEED RECORDED IN SAID OFFICIAL RECORDS IN BOOK 856, PAGE 1528; THENCE THE FOLLOWING (3) COURSES ALONG THE WESTERLY AND SOUTHERLY LINES OF LAST MENTIONED DEED: COURSE NO. 1- THENCE NORTH 89°15'00" EAST, 190.00 FEET TO A FOUND 1/2" IRON PIPE (STAMPED "LB 4238"); COURSE NO. 2- THENCE SOUTH 11°39'25" EAST, 463.37 FEET TO A FOUND 1/2" IRON PIPE (STAMPED "LB 4238"); COURSE NO. 3- THENCE NORTH 89°15'00" EAST, 457.74 FEET TO A 1/2" IRON PIPE (STAMPED "LB 4238") FOUND ON THE WESTERLY RIGHT-OF-WAY LINE OF STATE ROAD NO. A-1-A, (A 100 FOOT RIGHT-OF-WAY AS ESTABLISHED BY FLORIDA DEPARTMENT OF TRANSPORTATION RIGHT-OF-WAY MAP, SECTION NO. 78030-111 AND DATED MARCH 15, 1988); THENCE SOUTH 09°30'57" WEST, ALONG LAST MENTIONED RIGHT-OF-WAY LINE, 56.56 FEET TO A 1/2" IRON PIPE (STAMPED "LB 4238") FOUND ON THE NORTHERLY LINE OF WELL SITE NO. 1, AS DESCRIBED IN SPECIAL WARRANTY DEED RECORDED IN SAID OFFICIAL RECORDS IN BOOK 856, PAGE 1521; THENCE THE FOLLOWING (3) COURSES ALONG THE NORTHERLY, WESTERLY AND SOUTHERLY LINES OF SAID WELL SITE NO. 1: COURSE NO. 1- THENCE SOUTH 76°23'00" WEST, 73.51 FEET TO A FOUND 1/2" IRON PIPE (STAMPED "LB 4238"); COURSE NO. 2- THENCE SOUTH 13°37'00" EAST, 100.00 FEET TO A FOUND 1/2" IRON PIPE (STAMPED "LB 4238"); COURSE NO. 3- THENCE NORTH 76°23'00" EAST, 30.79 FEET TO A 1/2" IRON PIPE (STAMPED "LB 4238") FOUND ON THE AFOREMENTIONED WESTERLY RIGHT-OF-WAY LINE OF STATE ROAD NO. A-1-A; THENCE SOUTH 09°30'57" WEST, ALONG SAID WESTERLY RIGHT-OF-WAY LINE, 170.42 FEET TO A 1/2" IRON PIPE (STAMPED "LB 4622") SET AT A POINT OF CURVATURE IN SAID WESTERLY RIGHT-OF-WAY LINE; THENCE IN A SOUTHERLY DIRECTION, ALONG THE ARC OF A CURVE IN SAID WESTERLY RIGHT-OF-WAY LINE, SAID CURVE BEING CONCAVE EASTERLY AND HAVING A RADIUS OF 1232.30 FEET, A CHORD BEARING AND DISTANCE OF SOUTH 03°42'14" WEST, 249.57 FEET TO A 1/2" IRON PIPE SET ON THE NORTHERLY LINE OF WELL SITE NO. 2, AS DESCRIBED IN LAST MENTIONED SPECIAL WARRANTY DEED, THENCE THE FOLLOWING (3) COURSES ALONG THE NORTHERLY, WESTERLY AND SOUTHERLY LINES OF SAID WELL SITE NO. 2: COURSE NO. 1- THENCE SOUTH 87°11'41" WEST, 30.09 FEET TO A FOUND 1/2" IRON PIPE (STAMPED "LB 4238"); COURSE NO. 2- THENCE SOUTH 02°48'19" EAST, 30.00 FEET TO A FOUND 1/2" IRON PIPE (STAMPED "LB 4238"); COURSE NO. 3- THENCE NORTH 87°11'41" EAST, 30.09 FEET TO A 1/2" IRON PIPE (STAMPED "LB 4622") SET ON AFOREMENTIONED WESTERLY RIGHT-OF-WAY LINE; THENCE IN A SOUTHERLY DIRECTION, ALONG THE ARC OF A CURVE IN SAID WESTERLY RIGHT-OF-WAY LINE, SAID CURVE BEING CONCAVE EASTERLY AND HAVING A RADIUS OF 1232.30 FEET, A CHORD BEARING AND DISTANCE OF SOUTH 08°33'35" EAST, 217.25 FEET TO A 1/2" IRON PIPE (STAMPED "LB 4622") SET AT THE POINT OF TANGENCY OF SAID CURVE; THENCE SOUTH 13°37'00" EAST, CONTINUING ALONG SAID WESTERLY RIGHT-OF-WAY LINE, 295.13 FEET TO A 1/2" IRON PIPE SET AT A POINT OF CURVATURE IN SAID WESTERLY RIGHT-OF-WAY LINE; THENCE IN A SOUTHERLY DIRECTION, ALONG THE ARC OF A CURVE IN SAID WESTERLY RIGHT-OF-WAY LINE, SAID CURVE BEING CONCAVE EASTERLY AND HAVING A RADIUS OF 1232.30 FEET, A CHORD BEARING AND DISTANCE OF SOUTH 15°07'40" EAST, 64.99 FEET, TO A 1/2" IRON PIPE SET ON THE NORTHERLY LINE OF WELL SITE NO. 3, AS DESCRIBED IN LAST MENTIONED SPECIAL WARRANTY DEED; THENCE THE FOLLOWING (3) COURSES ALONG THE NORTHERLY, WESTERLY AND SOUTHERLY LINES OF SAID WELL SITE NO. 3: COURSE NO. 1- THENCE SOUTH 72°39'49" WEST, 30.09 FEET TO A FOUND 1/2" IRON PIPE (STAMPED "LB 4238"); COURSE NO. 2- THENCE SOUTH 17°20'11" EAST, 30.00 FEET TO A FOUND 1/2" IRON PIPE (STAMPED "LB 4238"); COURSE NO. 3- THENCE NORTH 72°39'49" EAST, 30.09 FEET TO A 1/2" IRON PIPE (STAMPED "LB 4622") SET ON AFOREMENTIONED WESTERLY RIGHT-OF-WAY LINE; THENCE IN A SOUTHEASTERLY DIRECTION, ALONG THE ARC OF A CURVE IN LAST MENTIONED WESTERLY RIGHT-OF-WAY LINE, SAID CURVE BEING CONCAVE NORTHEASTERLY AND HAVING A RADIUS OF 1232.30 FEET, A CHORD BEARING AND DISTANCE OF SOUTH 27°23'29" EAST, 400.74 FEET TO A 1/2" IRON PIPE (STAMPED "LB 4238") FOUND AT THE POINT OF TANGENCY OF SAID CURVE; THENCE SOUTH 36°44'57" EAST, ALONG SAID WESTERLY RIGHT-OF-WAY LINE, 85.00 FEET TO A 1/2" IRON PIPE (STAMPED "LB 4622") SET ON THE NORTHERLY LINE OF WELL SITE NO. 4, AS DESCRIBED IN LAST MENTIONED SPECIAL WARRANTY DEED, THENCE THE FOLLOWING (3) COURSES, ALONG THE NORTHERLY, WESTERLY AND SOUTHERLY LINES OF SAID WELL SITE NO. 4: COURSE NO. 1- THENCE SOUTH 53°15'03" WEST, 30.00 FEET TO A FOUND 1/2" IRON PIPE (STAMPED "LB 4238"); COURSE NO. 2- THENCE SOUTH 36°44'57" EAST, 30.00 FEET TO A FOUND 1/2" IRON PIPE (STAMPED "LB 4238"); COURSE NO. 3- THENCE NORTH 53°15'03" EAST, 30.00 FEET TO 1/2" IRON PIPE (STAMPED "LB 4622") SET ON LAST SAID WESTERLY RIGHT-OF-WAY LINE; THENCE SOUTH 36°44'57" EAST, ALONG SAID WESTERLY RIGHT-OF-WAY LINE, 344.74 FEET TO A 1/2" IRON PIPE (STAMPED "LB 4238") FOUND AT A POINT OF CURVATURE IN SAID WESTERLY RIGHT-OF-WAY LINE; THENCE IN A SOUTHEASTERLY DIRECTION, ALONG THE ARC OF A CURVE IN SAID WESTERLY RIGHT-OF-WAY LINE, SAID CURVE BEING CONCAVE SOUTHWESTERLY AND HAVING A RADIUS OF 1223.24 FEET, A CHORD BEARING AND DISTANCE OF SOUTH 33°35'15" EAST, 134.93 FEET TO A 1/2" IRON PIPE SET AT THE NORTHERLY LINE OF WELL SITE NO. 5, AS DESCRIBED IN LAST MENTIONED SPECIAL WARRANTY DEED, THENCE THE FOLLOWING (3) COURSES, ALONG THE NORTHERLY, WESTERLY AND SOUTHERLY LINES OF SAID WELL SITE NO. 5: COURSE NO. 1- THENCE SOUTH 60°16'36" WEST, 29.91 FEET TO A FOUND 1/2" IRON PIPE (STAMPED "LB 4238"); COURSE NO. 2- THENCE SOUTH 29°43'24" EAST, 30.00 FEET TO A FOUND 1/2" IRON PIPE (STAMPED "LB 4238"); COURSE NO. 3- THENCE NORTH 60°16'36" EAST, 29.91 FEET TO A 1/2" IRON PIPE (STAMPED "LB 4622") SET ON LAST SAID WESTERLY RIGHT-OF-WAY LINE; THENCE IN A SOUTHEASTERLY DIRECTION, ALONG THE ARC OF A CURVE IN SAID WESTERLY RIGHT-OF-WAY LINE, SAID CURVE BEING CONCAVE SOUTHWESTERLY AND HAVING A RADIUS OF 1223.24 FEET, A CHORD BEARING AND DISTANCE OF SOUTH 24°46'34" EAST, 181.07 FEET TO A 1/2" IRON PIPE (STAMPED "LB 4238") FOUND ON THE SOUTH LINE OF LANDS DESCRIBED IN DEED RECORDED IN THE OFFICIAL RECORDS OF SAID COUNTY IN BOOK 662, PAGE 270; THENCE SOUTH 89°15'00" WEST, ALONG LAST SAID SOUTH LINE, 1194.54 FEET TO THE POINT OF BEGINNING.

THE LAND THUS DESCRIBED CONTAINS 39.67 ACRES, MORE OR LESS.

**LESS AND EXCEPT:**

Master  
Legal Description

**OCEAN GRANDE  
AT SERENATA BEACH,  
A CONDOMINIUM**

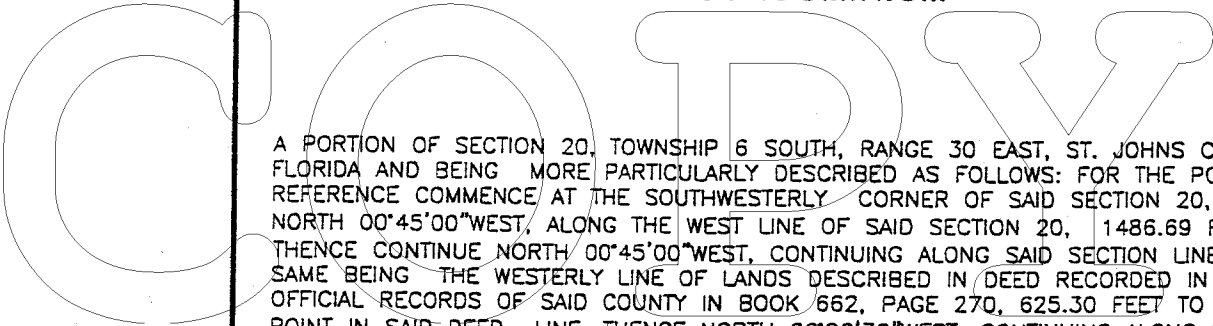

A PORTION OF SECTION 20, TOWNSHIP 6 SOUTH, RANGE 30 EAST, ST. JOHNS COUNTY, FLORIDA AND BEING MORE PARTICULARLY DESCRIBED AS FOLLOWS: FOR THE POINT OF REFERENCE COMMENCE AT THE SOUTHWESTERLY CORNER OF SAID SECTION 20, THENCE NORTH 00°45'00" WEST, ALONG THE WEST LINE OF SAID SECTION 20, 1486.69 FEET, THENCE CONTINUE NORTH 00°45'00" WEST, CONTINUING ALONG SAID SECTION LINE, THE SAME BEING THE WESTERLY LINE OF LANDS DESCRIBED IN DEED RECORDED IN THE OFFICIAL RECORDS OF SAID COUNTY IN BOOK 662, PAGE 270, 625.30 FEET TO AN ANGLE POINT IN SAID DEED LINE; THENCE NORTH 06°06'30" WEST, CONTINUING ALONG SAID DEED LINE, 348.14 FEET; THENCE NORTH 83°53'30" EAST, 162.00 FEET; THENCE SOUTH 81°09'02" EAST, 69.29 FEET; THENCE SOUTH 51°04'36" EAST, 34.41 FEET; THENCE NORTH 46°25'39" EAST, 18.88 FEET; THENCE NORTH 16°57'44" EAST, 28.34 FEET; THENCE NORTH 09°02'51" EAST, 284.26 FEET; THENCE NORTH 84°04'22" EAST, 59.97 FEET TO THE POINT OF BEGINNING.

FROM THE POINT OF BEGINNING THUS DESCRIBED, THENCE NORTH 24°02'08" WEST, 32.82 FEET; THENCE NORTH 13°37'00" WEST, 113.78 FEET; THENCE NORTH 24°10'58" WEST, 160.88 FEET; THENCE NORTH 11°18'42" EAST, 164.33 FEET; THENCE NORTH 14°02'46" WEST, 131.92 FEET; THENCE NORTH 58°00'18" EAST, 123.96 FEET; THENCE SOUTH 58°36'49" EAST, 130.77 FEET TO THE WESTERLY RIGHT-OF-WAY LINE OF STATE ROAD NO. A-1-A (A 100-FOOT RIGHT-OF-WAY AS NOW ESTABLISHED); THENCE IN A SOUTHERLY DIRECTION ALONG THE ARC OF A CURVE IN LAST SAID RIGHT-OF-WAY LINE, SAID CURVE BEING CONCAVE EASTERLY AND HAVING A RADIUS OF 1232.30 FEET, A CHORD BEARING AND DISTANCE OF SOUTH 02°21'26" WEST, 191.88 FEET; THENCE ALONG THE BOUNDARY OF WELL SITE NO.2, AS DESCRIBED IN DEED RECORDED IN THE OFFICIAL RECORDS OF SAID COUNTY IN BOOK 747, PAGE 619, THE FOLLOWING 3 COURSES, COURSE NO.1: SOUTH 87°11'41" WEST, 30.09 FEET; COURSE NO.2: SOUTH 02°48'19" EAST, 30.00 FEET; COURSE NO.3: NORTH 87°11'41" EAST, 30.09 FEET TO THE SAID WESTERLY RIGHT-OF-WAY LINE OF STATE ROAD NO. A-1-A; THENCE IN A SOUTHERLY DIRECTION ALONG THE ARC OF A CURVE IN LAST SAID RIGHT-OF-WAY LINE, SAID CURVE BEING CONCAVE EASTERLY AND HAVING A RADIUS OF 1232.30 FEET, A CHORD BEARING AND DISTANCE OF SOUTH 08°33'35" EAST, 217.25 FEET TO THE POINT OF TANGENCY OF SAID CURVE; THENCE SOUTH 13°37'00" EAST, CONTINUING ALONG LAST MENTIONED RIGHT-OF-WAY LINE, 114.81 FEET; THENCE SOUTH 76°23'00" WEST, 122.19 FEET; THENCE NORTH 84°53'36" WEST, 39.23 FEET; THENCE SOUTH 84°04'22" WEST, 6.08 FEET TO THE POINT OF BEGINNING.

THE LAND THUS DESCRIBED CONTAINS 2.62 ACRES, MORE OR LESS.

100 0 100 200  
SCALE: 1:200



COPY

# OCEAN GRANDE AT SERENATA BEACH, A CONDOMINIUM

## Phase II-Survey

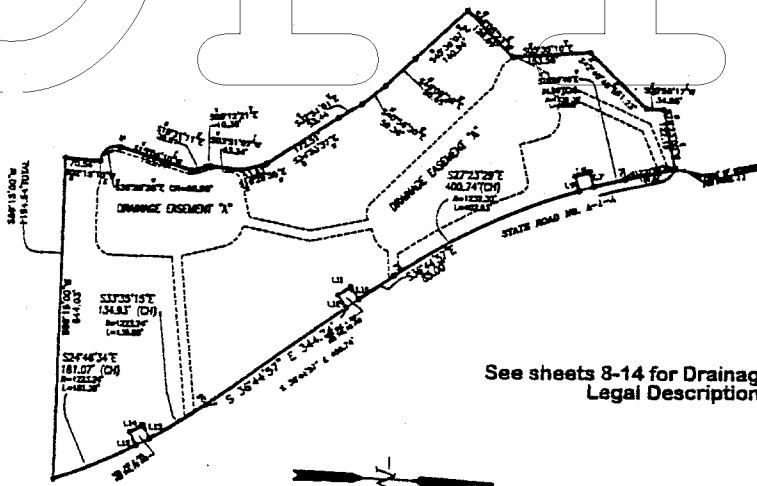

See sheets 8-14 for Drainage Easement  
Legal Descriptions.

## Phase II-Legal Description

A PORTION OF SECTION 20, TOWNSHIP 6 SOUTH, RANGE 30 EAST, ST. JOHNS COUNTY, FLORIDA AND BEING MORE PARTICULARLY DESCRIBED AS FOLLOWS: FOR THE POINT OF REFERENCE COMMENCE AT THE SOUTHWESTERLY CORNER OF SAID SECTION 20, THENCE NORTH 00°45'00" WEST, ALONG THE WEST LINE OF SAID SECTION 20, 1486.89 FEET, THENCE CONTINUE NORTH 00°45'00" WEST, CONTINUING ALONG SAID SECTION LINE, THE SAME BEING THE WESTERLY LINE OF LANDS DESCRIBED IN DEED RECORDED IN THE OFFICIAL RECORDS OF SAID COUNTY IN BOOK 662, PAGE 270, 625.30 FEET TO AN ANGLE POINT IN SAID DEED LINE, THENCE NORTH 06°06'30" WEST, CONTINUING ALONG SAID DEED LINE, 348.14 FEET; THENCE NORTH 83°53'30" EAST, 162.00 FEET; THENCE SOUTH 81°09'02" EAST, 89.29 FEET; THENCE SOUTH 51°04'36" EAST, 34.41 FEET; THENCE NORTH 48°25'39" EAST, 18.88 FEET; THENCE NORTH 16°57'44" EAST, 28.34 FEET; THENCE NORTH 09°02'51" EAST, 284.26 FEET; THENCE NORTH 84°04'22" EAST, 86.04 FEET; THENCE SOUTH 84°53'38" EAST, 39.23 FEET; THENCE NORTH 76°23'00" EAST, 122.19 FEET TO THE WESTERLY RIGHT-OF-WAY LINE OF STATE ROAD NO. A-1-A (A 100-FOOT RIGHT-OF-WAY AS NOW ESTABLISHED); THENCE SOUTH 13°37'00" EAST, ALONG SAID RIGHT-OF-WAY LINE, 78.65 FEET TO THE POINT OF BEGINNING.

FROM THE POINT OF BEGINNING THUS DESCRIBED, THENCE CONTINUE SOUTH 13°37'00" EAST, CONTINUING ALONG LAST SAID RIGHT-OF-WAY LINE, 101.67 FEET TO A POINT OF CURVATURE, THENCE IN A SOUTHERLY DIRECTION, ALONG THE ARC OF A CURVE IN SAID RIGHT-OF-WAY LINE, SAID CURVE BEING CONCAVE EASTERLY AND HAVING A RADIUS OF 1232.30 FEET, A CHORD BEARING AND DISTANCE OF SOUTH 13°07'40" EAST, 84.99 FEET;

THENCE ALONG THE BOUNDARY OF WELL SITE NO. 3, AS DESCRIBED IN DEED RECORDED IN THE OFFICIAL RECORDS OF SAID COUNTY IN VOLUME 747, PAGE 819, THE FOLLOWING 3 COURSES, COURSE NO. 1: SOUTH 72°39'49" WEST, 30.09 FEET; COURSE NO. 2: SOUTH 17°20'11" EAST, 30.00 FEET; COURSE NO. 3: NORTH 72°39'49" EAST, 30.09 FEET TO THE SAID WESTERLY RIGHT-OF-WAY LINE OF STATE ROAD NO. A-1-A; THENCE IN A SOUTHEASTERLY DIRECTION ALONG THE ARC OF A CURVE IN LAST SAID RIGHT-OF-WAY LINE, SAID CURVE BEING CONCAVE NORTHEASTERLY AND HAVING A RADIUS OF 1232.30 FEET, A CHORD BEARING AND DISTANCE OF SOUTH 27°23'29" EAST, 400.74 FEET TO THE POINT OF TANGENCY OF SAID CURVE; THENCE SOUTH 36°44'57" EAST, CONTINUING ALONG SAID RIGHT-OF-WAY LINE, 85.0 FEET;

THENCE ALONG THE BOUNDARY OF WELL SITE NO. 4, PER SAID DEED RECORDED IN OFFICIAL RECORDS VOLUME 747, PAGE 619, THE FOLLOWING 3 COURSES, COURSE NO. 1: SOUTH 53°15'03" WEST, 30.00 FEET; COURSE NO. 2: SOUTH 36°44'57" EAST, 30.00 FEET; COURSE NO. 3: NORTH 53°15'03" EAST, 30.00 FEET TO THE SAID SOUTHWESTERLY RIGHT-OF-WAY LINE OF STATE ROAD NO. A-1-A; THENCE SOUTH 36°44'57" EAST, ALONG SAID RIGHT-OF-WAY LINE, 344.74 FEET TO A POINT OF CURVATURE; THENCE IN A SOUTHEASTERLY DIRECTION, ALONG THE ARC OF A CURVE IN LAST SAID RIGHT-OF-WAY LINE, SAID CURVE BEING CONCAVE SOUTHWESTERLY AND HAVING A RADIUS OF 1223.24 FEET, A CHORD BEARING AND DISTANCE OF SOUTH 33°25'15" EAST, 134.93 FEET; THENCE ALONG THE BOUNDARY OF WELL SITE NO. 5, ACCORDING TO SAID DEED RECORDED IN OFFICIAL RECORDS BOOK 747, PAGE 819, THE FOLLOWING 3 COURSES, COURSE NO. 1: SOUTH 60°16'36" WEST, 29.91 FEET; COURSE NO. 2: SOUTH 29°43'24" EAST, 30.00 FEET; COURSE NO. 3: NORTH 60°16'36" EAST, 29.91 FEET TO THE SAID SOUTHWESTERLY RIGHT-OF-WAY LINE OF STATE ROAD NO. A-1-A; THENCE IN A SOUTHEASTERLY DIRECTION, ALONG THE ARC OF A CURVE IN LAST SAID RIGHT-OF-WAY LINE, SAID CURVE BEING CONCAVE SOUTHWESTERLY AND HAVING A RADIUS OF 1223.24 FEET, A CHORD BEARING AND DISTANCE OF SOUTH 24°46'34" EAST, 181.07 FEET; THENCE SOUTH 89°15'00" WEST, ALONG THE SOUTH LINE OF LANDS DESCRIBED IN DEED RECORDED IN THE OFFICIAL RECORDS OF SAID COUNTY IN BOOK 662, PAGE 270, 644.03 FEET; THENCE NORTH 02°15'10" EAST, 70.54 FEET; THENCE IN A NORTHWESTERLY DIRECTION, ALONG THE ARC OF A CURVE, SAID CURVE BEING CONCAVE NORTHEASTERLY AND HAVING A RADIUS OF 32.50 FEET, A CHORD BEARING AND DISTANCE OF NORTH 36°20'20" WEST, 30.80 FEET; THENCE NORTH 15°04'10" EAST, 153.71 FEET; THENCE NORTH 18°31'11" WEST, 28.91 FEET; THENCE NORTH 05°12'21" WEST, 10.36 FEET; THENCE NORTH 03°51'07" EAST, 83.34 FEET; THENCE NORTH 16°29'55" WEST, 53.83 FEET; THENCE NORTH 34°53'37" WEST, 172.51 FEET; THENCE NORTH 32°51'01" WEST, 53.44 FEET; THENCE NORTH 40°56'20" WEST, 59.36 FEET; THENCE NORTH 46°09'28" WEST, 80.85 FEET; THENCE NORTH 45°39'07" WEST, 140.94 FEET; THENCE NORTH 44°05'23" EAST, 128.89 FEET; THENCE NORTH 05°35'10" WEST, 153.59 FEET; THENCE NORTH 42°40'46" EAST, 161.23 FEET; THENCE NORTH 00°56'17" EAST, 34.95 FEET; THENCE NORTH 76°23'00" EAST, 122.19 FEET TO THE POINT OF BEGINNING.

150 0 150 300  
SCALE: 1:300

OCEAN GRANDE  
AT SERENATA BEACH,  
A CONDOMINIUM

Phase III-Survey

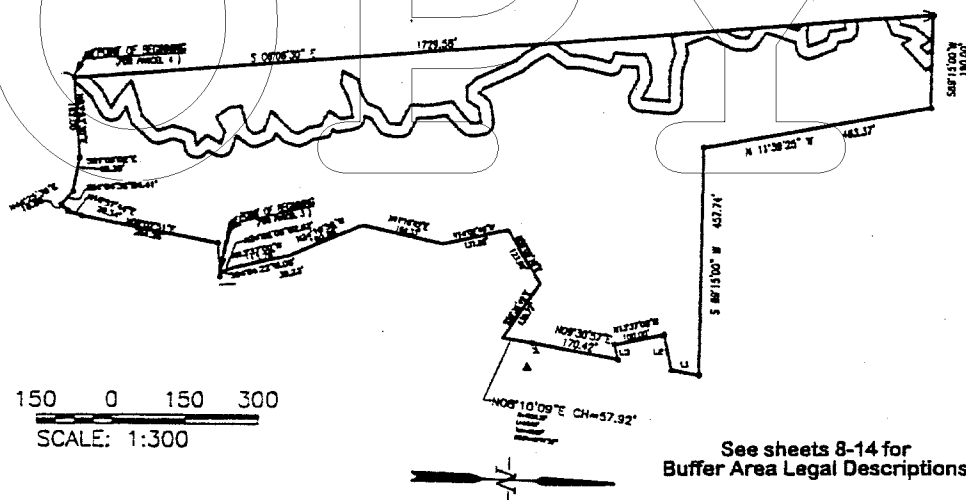

Phase III-Legal Description

A PORTION OF SECTIONS 19, AND 20, TOWNSHIP 6 SOUTH, RANGE 30 EAST, ST. JOHNS COUNTY, FLORIDA AND BEING MORE PARTICULARLY DESCRIBED AS FOLLOWS: FOR THE POINT OF REFERENCE COMMENCE AT THE SOUTHWESTERLY CORNER OF SAID SECTION 20, THENCE NORTH 00°45'00" WEST, ALONG THE WEST LINE OF SAID SECTION 20, 1486.69 FEET; THENCE CONTINUE NORTH 00°45'00" WEST, CONTINUING ALONG SAID SECTION LINE, THE SAME BEING THE WESTERLY LINE OF LANDS DESCRIBED IN DEED RECORDED IN THE OFFICIAL RECORDS OF SAID COUNTY IN BOOK 662, PAGE 270, 625.30 FEET TO AN ANGLE POINT IN SAID DEED LINE; THENCE NORTH 06°06'30" WEST, CONTINUING ALONG SAID DEED LINE, 348.14 FEET TO THE POINT OF BEGINNING,

FROM THE POINT OF BEGINNING THUS DESCRIBED; THENCE NORTH 83°53'30" EAST, 162.00 FEET; THENCE SOUTH 81°09'02" EAST, 69.29 FEET; THENCE SOUTH 51°04'36" EAST, 34.41 FEET; THENCE NORTH 46°25'39" EAST, 18.88 FEET; THENCE NORTH 16°57'44" EAST, 28.34 FEET; THENCE NORTH 09°02'51" EAST, 284.26 FEET; THENCE NORTH 84°04'22" EAST, 59.97 FEET; THENCE NORTH 24°02'08" WEST, 32.82 FEET; THENCE NORTH 13°37'00" WEST, 113.78 FEET; THENCE NORTH 24°10'58" WEST, 160.88 FEET; THENCE NORTH 11°18'42" EAST, 164.33 FEET; THENCE NORTH 14°02'46" WEST, 131.92 FEET; THENCE NORTH 58°00'18" EAST, 123.96 FEET; THENCE SOUTH 58°36'49" EAST, 130.77 FEET TO THE WESTERLY RIGHT-OF-WAY LINE OF STATE ROAD NO. A-1-A (A 100-FOOT RIGHT-OF-WAY AS NOW ESTABLISHED); THENCE IN A NORTHERLY DIRECTION, ALONG THE ARC OF A CURVE IN LAST SAID RIGHT-OF-WAY LINE, SAID CURVE BEING CONCAVE EASTERLY AND HAVING A RADIUS OF 1232.30 FEET, A CHORD BEARING AND DISTANCE OF NORTH 08°10'09" EAST, 57.92 FEET TO THE POINT OF TANGENCY OF SAID CURVE; THENCE NORTH 09°30'57" EAST, CONTINUING ALONG LAST SAID RIGHT-OF-WAY LINE, 170.42 FEET; THENCE ALONG THE BOUNDARY OF WELL SITE NO.1 AS DESCRIBED IN DEED RECORDED IN THE OFFICIAL RECORDS OF SAID COUNTY IN BOOK 747, PAGE 619, THE FOLLOWING 3 COURSES, COURSE NO.1: SOUTH 76°23'00" WEST, 30.79 FEET; COURSE NO.2: NORTH 13°37'00" WEST, 100.00 FEET; COURSE NO.3: NORTH 76°23'00" EAST, 73.51 FEET TO THE SAID WESTERLY RIGHT-OF-WAY LINE OF STATE ROAD NO. A-1-A; THENCE NORTH 09°30'57" EAST, 56.56 FEET; THENCE SOUTH 89°15'00" WEST, ALONG THE SOUTHERLY LINE OF LANDS DESCRIBED IN DEED RECORDED IN THE OFFICIAL RECORDS OF SAID COUNTY IN BOOK 762, PAGE 1499, 457.74 FEET TO THE SOUTHWESTERLY CORNER OF SAID LANDS; THENCE NORTH 11°39'25" WEST, ALONG THE WESTERLY LINE OF LAST MENTIONED LANDS, 463.37 FEET; THENCE SOUTH 89°15'00" WEST, 190.00 FEET TO THE WEST LINE OF SAID LANDS DESCRIBED IN OFFICIAL RECORDS BOOK 662, PAGE 270; THENCE SOUTH 06°06'30" EAST, ALONG SAID WESTERLY LINE, 1729.58 FEET TO THE POINT OF BEGINNING.

THE LAND THUS DESCRIBED CONTAINS 14.76 ACRES, MORE OR LESS.

# OCEAN GRANDE AT SERENATA BEACH, A CONDOMINIUM

COPY

PHASE 3  
(FUTURE DEVELOPMENT)

NOT A  
PART

PHASE 2  
(FUTURE DEVELOPMENT)

PHASE 1



150 0 150 300  
SCALE: 1:300

Master  
Site Plan

## EXHIBIT C

### SHARE OF COMMON ELEMENTS AND COMMON EXPENSES

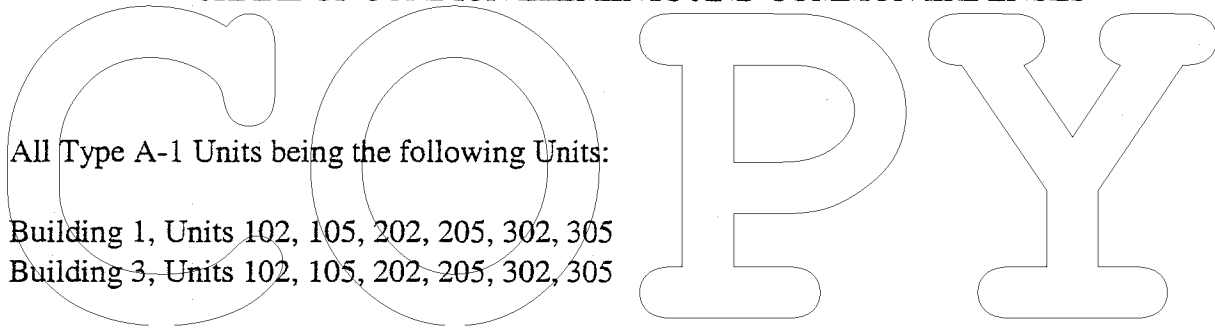

All Type A-1 Units being the following Units:

- Building 1, Units 102, 105, 202, 205, 302, 305
- Building 3, Units 102, 105, 202, 205, 302, 305

Number of units	Square footage	Fractional share
12	2,035	2,035/127,020

All Type A-2 Units being the following Units:

- Building 1, Units 103, 104, 203, 204, 303, 304
- Building 2, Units 102, 103, 202, 203, 302, 303
- Building 3, Units 103, 104, 203, 204, 303, 304
- Building 4, Units 102, 103, 202, 203, 302, 303

Number of units	Square footage	Fractional share
24	2,036	2,036/127,020

All Type B Units being the following Units:

- Building 1, Units 101, 106, 201, 206, 301, 306
- Building 2, Units 101, 104, 201, 204, 301, 304
- Building 3, Units 101, 106, 201, 206, 301, 306
- Building 4, Units 101, 104, 201, 204, 301, 304

Number of units	Square footage	Fractional share
24	2,239	2,239/127,020

EXHIBIT D

OR1739PG1848

State of Florida



Department of State

I certify the attached is a true and correct copy of the Articles of Incorporation of OCEAN GRANDE CONDOMINIUM ASSOCIATION, INC., a Florida corporation, filed on March 28, 2002, as shown by the records of this office.

I further certify the document was electronically received under FAX audit number H02000067103. This certificate is issued in accordance with section 15.16, Florida Statutes, and authenticated by the code noted below.

The document number of this corporation is N02000002260.

Given under my hand and the  
Great Seal of the State of Florida,  
at Tallahassee, the Capital, this the  
Twenty-eighth day of March, 2002

Authentication Code: 002A00018565-032802-N02000002260-1/1



CR2EO22 (1-99)

*Katherine Harris*

Katherine Harris  
Secretary of State

ARTICLES OF INCORPORATION  
OF  
OCEAN GRANDE CONDOMINIUM ASSOCIATION, INC.

OR1739PG1849

The undersigned, for the purpose of forming a not-for-profit corporation in accordance with the laws of the State of Florida, acknowledge and file these Articles of Incorporation in the Office of the Secretary of State of the State of Florida.

I.  
NAME

The name of this corporation shall be OCEAN GRANDE CONDOMINIUM ASSOCIATION, INC. For convenience, the corporation shall herein be referred to as the "Association."

II.  
PURPOSES AND POWERS

The Association shall have the following powers:

- A. To manage, operate and administer OCEAN GRANDE AT SERENATA BEACH, a Condominium (referred to herein as the "Condominium"), and to undertake the performance of, and to carry out the acts and duties incident to, the administration of the Condominium in accordance with the terms, provisions, conditions and authorizations contained in these Articles, the Association's By-Laws and the Declaration of Condominium recorded among the public records of St. Johns County, Florida.
- B. To borrow money and issue evidences of indebtedness in furtherance of any or all of the objects of its business; to secure the same by mortgage, deed of trust, pledge or other lien.
- C. To carry out the duties and obligations and receive the benefits given the Association by the Declaration of Condominium.
- D. To establish By-Laws and Rules and Regulations for the operation of the Association and to provide for the formal administration of the Association; to enforce the Declaration of Condominium, the By-Laws and the Rules and Regulations of the Association.
- E. To contract for the management of the Condominium.
- F. To acquire, own, operate, mortgage, lease, sell and trade property, whether real or personal, as may be necessary or convenient in the administration of the Condominium.
- G. The Association shall have all of the common law and statutory powers and duties set forth in Chapter 718, Florida Statutes, as amended (the "Condominium

Act”), Chapters 607 and 617, Florida Statutes, as amended, and the Declaration of Condominium for the Condominium and all other powers and duties reasonably necessary to operate the Condominium pursuant to its Declaration of Condominium, as same may be amended from time to time.

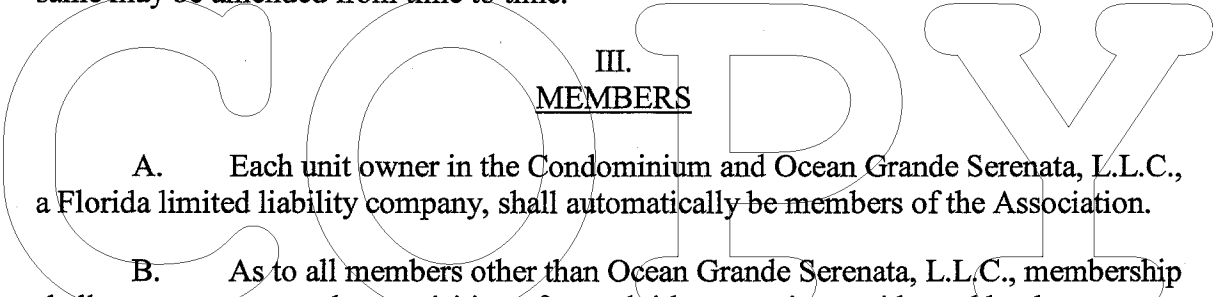

III.  
MEMBERS

A. Each unit owner in the Condominium and Ocean Grande Serenata, L.L.C., a Florida limited liability company, shall automatically be members of the Association.

B. As to all members other than Ocean Grande Serenata, L.L.C., membership shall commence upon the acquisition of record title to a unit as evidenced by the recording of a deed of conveyance amongst the public records of St. Johns County, Florida, or, as provided in the Declaration of Condominium, upon transfer of title upon the death of a member, and membership shall terminate upon the divestment of title to said unit.

C. On all matters as to which the membership shall be entitled to vote, there shall be only one vote for each unit, which vote shall be exercised in the manner provided by the Declaration of Condominium and the By-Laws.

D. The share of a member in the funds and assets of the Association cannot be assigned, hypothecated or transferred in any manner except as an appurtenance to such member’s unit.

IV.  
EXISTENCE

The Association shall have perpetual existence.

V.  
SUBSCRIBERS

The name and address of the Subscriber to these Articles of Incorporation is as follows:

<u>NAME</u>	<u>ADDRESS</u>
Wallace R. Devlin	1548 The Greens Way, Suite 3 Jacksonville Beach, Florida 32250

VI.  
DIRECTORS

A. The Condominium and Association affairs shall be managed by a Board of Directors initially composed of three persons, in accordance with Article III of the Association’s By-Laws.

OR1739PG1851

B. The number of Directors to be elected, the manner of their election and their respective terms shall be as set forth in Article III of the Association's By-Laws.

The following persons shall constitute the initial Board of Directors and they shall hold office for the term and in accordance with the provisions of Article III of the Association's By-Laws.

NAME

Wallace R. Devlin

Luis Lamar

Edward R. McCue, Jr.

ADDRESS

1548 The Greens Way, Suite 3  
Jacksonville Beach, Florida 32250

848 Brickell Avenue, Suite 810  
Miami, Florida 33131

1548 The Greens Way, Suite 3  
Jacksonville Beach, Florida 32250

VII.  
BY-LAWS

The By-Laws of the Association shall be adopted by the initial Board of Directors. The By-Laws may be amended in accordance with the provisions hereof, except that no portion of the By-Laws may be altered, amended, or rescinded in such a manner as would prejudice the rights of the Developer of the Condominium or mortgagees holding mortgages encumbering units in the Condominium, without their prior written consent.

VIII.  
AMENDMENTS TO ARTICLES

Amendments to these Articles shall be proposed and adopted in the following manner:

A. Notice of the subject matter of any proposed amendment shall be included in the notice of the meeting at which the proposed amendment is to be considered.

B. A resolution for the adoption of a proposed amendment may be proposed either by the Board of Directors, acting upon the vote of a majority of the Board of Directors, or by the members of the Association having a majority of the votes in the Association. In order for any amendment or amendments to be effective, same must be approved by an affirmative vote of 66-2/3% of the entire Board of Directors and by an affirmative vote of not less than 66-2/3% of the members present, either in person or by proxy, at a duly called meeting of the members of the Association.

C. No amendment shall make any changes in the qualifications for membership nor in the voting rights of members of the Association, without approval in writing by all members and the joinder of all record owners of mortgages encumbering



0R1739PG1852

condominium units. No amendment shall be made that is in conflict with the Condominium Act or the Declaration of Condominium.

D. A copy of each amendment adopted shall be filed within ten (10) days of adoption with the Secretary of State, pursuant to the provisions of applicable Florida Statutes.

IX.  
INDEMNIFICATION

Every Director and every Officer of the Association shall be indemnified by the Association and by each member of the Association against all expenses and liabilities, including counsel fees reasonably incurred by or imposed upon the Director(s) or Officer(s) in connection with any proceeding or any settlement thereof to which the Director(s) or Officer(s) may be a party, or in which the Director(s) or Officer(s) may become involved by reason of the Director(s) or Officer(s) being or having been a Director(s) or Officer(s) of the Association, whether or not a Director(s) or Officer(s) at the time such expenses are incurred, except in such cases wherein the Director(s) or Officer(s) is adjudged guilty of willful misconduct in the performance of such Director's or Officer's duty; provided that in the event of a settlement, the indemnification set forth herein shall apply only when the Board of Directors, exclusive of any Director(s) seeking indemnification, approves such settlement and reimbursement as being in the best interest of the Association. The foregoing right of indemnification shall be in addition to and not exclusive of all of the rights to which such Director(s) or Officer(s) may be entitled.

X.  
INITIAL REGISTERED OFFICE, AGENT AND ADDRESS

The principal office of the Association shall be at: 1548 The Greens Way, Suite 3, Jacksonville Beach, Florida 32250, or at such other place, within or without the State of Florida as may be subsequently designated by the Board of Directors. The initial registered office of the Association is at 1548 The Greens Way, Suite 3, Jacksonville Beach, Florida 32250, and the initial registered agent therein is Wallace R. Devlin.

IN WITNESS WHEREOF, the undersigned has made and subscribed these Articles of Incorporation at Jacksonville, Duval County, Florida, for the uses and purposes aforesaid, this 26 day of March, 2002.

  
\_\_\_\_\_  
Wallace R. Devlin

DR1739PG1853

CERTIFICATE OF ACCEPTANCE OF DESIGNATION OF  
REGISTERED AGENT OF  
OCEAN GRANDE CONDOMINIUM ASSOCIATION, INC.

Pursuant to Sections 48.091 and 617.023, Florida Statutes, the undersigned, having been designated as the initial Registered Agent for the service of process within the State of Florida upon Ocean Grande Condominium Association, Inc., a not-for-profit corporation organized under the laws of the State of Florida, does hereby accept the appointment as such Registered Agent for the above-named corporation, and does hereby agree to comply with the provisions of Section 48.091(2) relative to keeping open the Registered Office of said corporation, which Registered Office is located at 1548 The Greens Way, Suite 3, Jacksonville Beach, Florida 32250.

IN WITNESS WHEREOF, I, such designated Registered Agent, have hereunto set my hand and seal in Jacksonville, Duval County, Florida, on this 26 day of March, 2002.

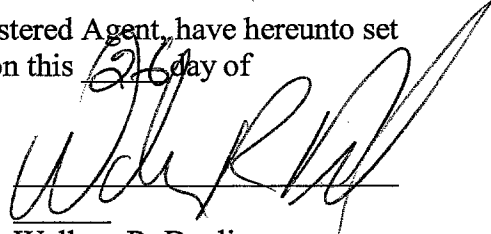

Wallace R. Devlin  
Registered Agent

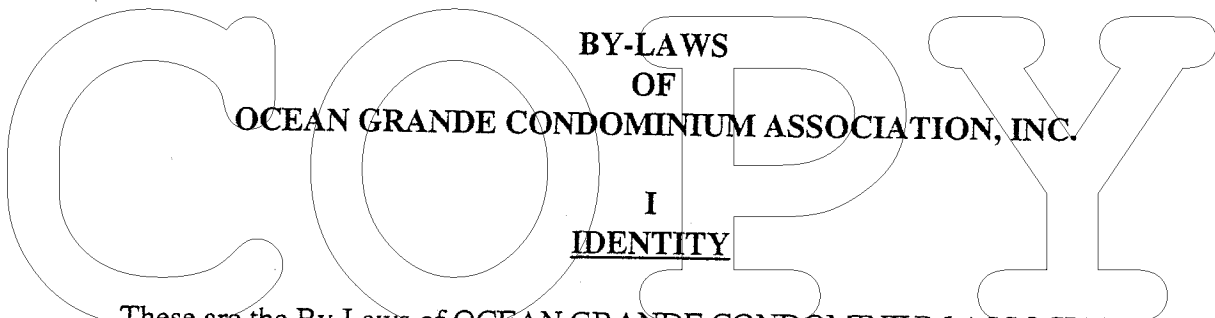
**EXHIBIT E**

These are the By-Laws of OCEAN GRANDE CONDOMINIUM ASSOCIATION, INC., a not-for-profit Florida corporation ("Association").

**II  
PURPOSES**

This Association has been organized for the purpose of being a condominium association within the meaning of the Condominium Act of the State of Florida (the "Act"), and in turn for the purpose of operating, governing, administering and managing the property and affairs of Ocean Grande at Serenata Beach, a Condominium (the "Condominium") and to exercise all powers granted to it as a corporation under the laws of the State of Florida, these By-Laws, the Articles of Incorporation and the Declaration of Condominium (the "Declaration of Condominium") to which these By-Laws are attached and, further, to exercise all powers granted to a condominium association under the Act.

**III  
DIRECTORS AND OFFICERS****A. Directors.**

1. The affairs of the Association shall be managed by an Initial Board of Directors (the "Initial Board") composed of three (3) persons. The members of the Initial Board are designated in the Articles of Incorporation and need not be members of the Association. When unit owners other than the Developer own 15 percent or more of the units in the Condominium, the unit owners other than the developer shall be entitled to elect no less than one-third of the members of the Board of Directors of the Association. Unit owners other than the developer are entitled to elect not less than a majority of the members of the Board of Directors of the Association:

- a. Three years after 50 percent of the units that will be operated ultimately by the Association have been conveyed to purchasers;
- b. Three months after 90 percent of the units that will be operated ultimately by the Association have been conveyed to purchasers;

- c. When all the units that will be operated ultimately by the Association have been completed, some of them have been conveyed to purchasers, and none of the others are being offered for sale by the developer in the ordinary course of business;
- d. When some of the units have been conveyed to purchasers and none of the others are being constructed or offered for sale by the developer in the ordinary course of business; or
- e. Seven years after recordation of the declaration of condominium creating the initial phase of the Condominium,

whichever of a through e above occurs first. The developer is entitled to elect at least one member of the Board of Directors of the Association as long as the developer holds for sale in the ordinary course of business at least five percent of the units in the Condominium.

Following the time the Developer relinquishes control of the Board of Directors of the Association, the Developer may exercise the right to vote any developer-owned units in the Condominium in the same manner as any other unit owner, except for the purposes of reacquiring control of the Board of Directors of the Association or selecting the majority members of the Board of Directors of the Association. Until such time as the purchaser members shall be entitled to elect all of the Directors, the Developer shall have the absolute right, in its sole and absolute discretion and at any time, to remove any Director selected by the Developer and to replace the Director so discharged.

2. The purchaser members shall elect a majority of the Board of Directors, pursuant to the provisions hereof, at a special meeting of the Membership to be called by the Board for such purpose (the "Majority Election Meeting").

3. Subsequent to the Majority Election Meeting, the Directors shall be elected by the members of the Association at each annual meeting of members and the Directors shall hold office until the next annual meeting of members and until their successors are elected and shall qualify.

4. Directors shall be elected at the Majority Election Meeting and at each annual meeting of the members, as follows:

a. The Board of Directors shall be elected by written ballot or voting machine. Any election to fill a vacancy on the Board of Directors due to the expiration of a Director's term, shall be by secret ballot. However, in the event the number of vacancies equals or exceeds the number of candidates, no election is required. Except to fill vacancies on the Board of Directors caused by recall, proxies shall in no event be used in electing the Board of Directors, either at general elections or at elections to fill vacancies caused by resignation. Not less than sixty (60) days before a scheduled

election, the Secretary shall mail or deliver, whether by separate Association mailing or included in another Association mailing or delivery including regularly published newsletters, to each member of the Association entitled to vote, a first notice of the date of the election. Any member of the Association or other eligible person desiring to be a candidate for the Board of Directors shall give written notice to the Secretary of the Association not less than forty (40) days before a scheduled election. Together with the written notice and agenda required pursuant to the provisions of Article VII, Subparagraph A3 of these By-Laws, the Association shall then mail or deliver a second notice of the election to all members of the Association entitled to vote therein, together with a ballot which shall list all candidates. Upon request of a candidate, the Association shall include an information sheet, no larger than 8-1/2 inches by 11 inches furnished by the candidate, to be included with the mailing of the ballot, with the costs of mailing or delivery and copying to be borne by the Association. Elections shall be decided by a plurality of those ballots cast. There shall be no quorum requirement; however, at least twenty percent (20%) of the members must cast a ballot to have a valid election. No member of the Association shall permit any other to vote such member's ballot, and any such ballots improperly cast shall be deemed invalid. The regular election shall occur on the date of the annual meeting of the membership of the Association.

5. Directors shall be members of the Association, except that this provision shall not apply to Directors selected by the Developer.

6. No person who has been convicted of any felony by any court of record in the United States and who has not had his or her right to vote restored pursuant to law in the jurisdiction of his or her residence is eligible for membership on the Board of Directors.

**B. Officers.**

The Officers of the Association shall consist of a President, a Vice President, a Secretary and a Treasurer, any of whom may be members of the Board of Directors, and such other Officers as the Board of Directors may appoint. The President must be a member of the Board of Directors. The Officers named in the Articles of Incorporation shall serve, unless removed and replaced by the Developer, until the first meeting of the Board of Directors held subsequent to the Majority Election Meeting, and at such meeting the Board of Directors shall elect the aforesaid Officers. Officers elected at the first meeting of the Board of Directors held subsequent to the Majority Election Meeting, shall hold office until the next and ensuing annual meeting of the Board of Directors and until their successors shall have been elected and shall qualify.

**C. Resignation, Vacancy, Removal, Compensation.**

1. Any Director or Officer of the Association may resign at any time, by instrument in writing. Resignations shall take effect at the time specified therein, and if no time is specified, at the time of receipt of such resignation by the President or Secretary of the Association. The acceptance of

a resignation shall not be necessary to make it effective. A resignation shall be deemed to have occurred upon termination of membership in the Association, by a Director or Officer.

2. Subject to the right of the Developer to replace Directors selected by the Developer, the members of the Association, at a Special Meeting of the membership, shall fill any vacancy on the Board of Directors by electing a person who shall serve until the next annual meeting of the members. In the event of a vacancy on the Board of Directors caused by a recall of a Director, pursuant to the provisions of Section 718.112(2)(k), Florida Statutes, the members of the Association, at a Special Meeting of the membership, shall fill the vacancy on the Board of Directors, by electing a person who shall serve until the next annual meeting of the members.

When a vacancy occurs in an office for any cause before an Officer's term has expired, the office shall be filled by the Board of Directors at its next meeting by electing a person to serve for the unexpired term.

3. Any Director may be recalled and removed from office, with or without cause, pursuant to the provisions of Section 718.112(2)(k), Florida Statutes. Directors selected by the Developer shall not be affected by these provisions.

4. Upon an affirmative vote of a majority of the members of the Board of Directors in attendance at any meeting at which a quorum is present, any Officer may be removed either with or without cause, and his successor elected at any regular meeting of the Board of Directors, or at any special meeting called for such purpose.

5. No compensation shall be paid to Directors or Officers for their services as Directors or Officers.

#### IV

#### POWERS AND DUTIES OF THE ASSOCIATION AND THE EXERCISE THEREOF

The Association shall have all powers granted to it by law, the Declaration of Condominium, the Act as the same may be amended from time to time, and the Articles of Incorporation, all of which powers shall be exercised by its Board of Directors unless the exercise thereof is otherwise restricted by the Declaration of Condominium, these By-Laws, or by law; and the aforementioned powers of the Association shall include, but shall not be limited to, the following:

A. All of the powers specifically provided for in the Declaration of Condominium and the Act.

B. The power to levy and collect assessments, based upon a budget formally adopted by the Board of Directors; provided, however, the Association shall not charge any fee for use by members

of the common elements or of property owned by the Association, unless such use is the subject of a lease between the Association and the members. It is understood, however, that the failure of the Board of Directors or the members of the Association to adopt a budget shall not impair or affect the members' obligations to pay their share of the common expenses of the Condominium.

C. The power to acquire, convey, mortgage, operate, lease, manage and otherwise trade and deal with property, real and personal, including units in the Condominium, as may be necessary or convenient in the operation and management of the Condominium and in accomplishing the purposes set forth in the Declaration of Condominium.

D. The power to expend monies collected for the purpose of paying the common expenses of the Association.

E. The power to purchase equipment, supplies and material required in the maintenance, repair, replacement, operation and management of the common elements of the Condominium.

F. The power to insure and keep insured the buildings and improvements of the Condominium as provided for and limited by the Declaration of Condominium. This Association shall, not less than forty-five (45) days prior to the effective date of any renewals or amendments to the Association's insurance coverage, notify each member of the changes to be made in the Association's insurance coverage, including a description of the property previously covered by the Association's insurance coverage which will no longer be covered and the effective date of such change.

G. The power to employ the personnel required for the operation of the common elements of the Condominium and the Association.

H. The power to pay utility bills for utilities serving the common elements of the Condominium.

I. The power to contract for the management of the Condominium.

J. The power to make reasonable rules and regulations and to amend them from time to time, and to see that all members are notified of such changes in the rules and regulations as may be enacted.

K. The power to improve the Condominium property, subject to the limitations of the Declaration of Condominium.

L. The power to enforce by any legal means the provisions of the Articles of Incorporation, the By-Laws, the Declaration of Condominium and the Rules and Regulations duly promulgated by the Association.

M. The power to collect delinquent assessments by suit or otherwise, and to abate nuisance and enjoin or seek damages from unit owners for violation of the provisions of the Declaration of Condominium and its Exhibits.

N. The power to pay all taxes and assessments which are or may become liens against the common elements of the Condominium, and to assess the same against the members and their units.

O. The power to select depositories for the Association funds, and to determine the manner of receiving, depositing and disbursing Association funds, and the form of check and the person or persons by whom the same shall be signed, when not signed as otherwise provided by these By-Laws.

P. The power to possess and exercise all powers necessary to implement, enforce and carry into effect the powers above described, including the power to acquire, hold, mortgage, convey, and deal in real and personal property.

Q. The power to enter into, ratify, modify and amend each and every one of the agreements and undertakings contemplated by and contained within the Declaration of Condominium.

R. The power to subscribe to and enter into a contract with any person, firm, corporation or real estate management agent of any nature or kind to provide for the maintenance, operation, repair and upkeep of the Condominium property. Said contract may provide that the total operation of said managing agent, firm, or corporation shall be at the cost of the Association. Said contract may further provide that the managing agent shall be paid from time to time a reasonable fee, either stated as a fixed fee or a variable fee or as a percentage of the total cost of maintenance, operation, repair and upkeep, or of the total funds of the Association handled and managed by the managing agent.

V

**DUTIES OF OFFICERS**

A. The President shall:

1. Act as Presiding Officer at all meetings of the membership of the Association and of the Board of Directors.
2. Call special meetings of the Board of Directors and of members.
3. Sign all checks, contracts, promissory notes, deeds, and other instruments on behalf of the Association, except those which the Board of Directors specifies may be signed by other persons.



4. Perform all acts and duties usually required of an executive to insure that all orders and resolutions of the Board of Directors are carried out.

5. Appoint committees and be an ex-officio member of all committees, and render an annual report at the annual meeting of members.

B. The Vice President shall:

1. Act as Presiding Officer at all meetings of the membership of the Association and of the Board of Directors when the President is absent.

2. Perform all other acts and duties required of the President, in the absence of the President.

3. Perform such other duties as may be required by the Board.

4. Sign checks on behalf of the Association in the absence of the President.

C. Should the President and Vice President be absent from any meeting, the Directors present at the meeting shall select a person to act as chairman of the meeting.

D. The Secretary shall:

1. Attend all regular and special meetings of the members of the Association and of the Board of Directors and keep all records and minutes of proceedings thereof or cause the same to be done.

2. Have custody of the corporate seal and affix same when necessary or required.

3. Attend to all correspondence on behalf of the Board of Directors, prepare and serve notices of meetings, keep membership books and receive all applications for membership, for transfer and sale of units, and present such applications to the Board of Directors.

4. Perform such other duties as the Board may determine and on all occasions in the execution of his duties, act under the supervision, control and direction of the Board of Directors.

5. Have custody of the minute book of the meetings of the Board of Directors and of the members, which minute book shall at all reasonable times be available at the office of the Association for inspection by members, or their authorized representatives, and by the Directors, and act as transfer agent to record transfers and rules and regulations in the corporate books. Minutes of all meetings of the Board of Directors and of members shall be reduced to writing and shall be available for

inspection by members, or their authorized representatives, within thirty (30) days after the date of each such meeting. The minutes of all meetings of the Board of Directors and of the members shall be retained by the Secretary for a period of not less than seven (7) years.

6. Ballots, sign-in sheets voting proxies and all other papers relating to elections shall be maintained as part of the Association Records (as herein defined) for a period of one (1) year from the date of the meeting to which such documents relate.

7. If the Association owns, leases or has reasonable access to a photocopy machine, the Association shall, at the request of any member or the authorized representative of such member, make photocopies of Association Records, as requested by such member or by the authorized representative of such member. The Association shall not charge any fee to the member or to the authorized representative of such member in connection with inspection of the Association Records, except that the Association may charge a reasonable fee for the cost of making copies.

8. Maintain copies of all documents required to be maintained by the Association in accordance with Section 718.111(12), Florida Statutes (the "Association Records"). The Association Records shall be maintained in St. Johns County, Florida and shall be open to inspection by any member, or the authorized representative of such member, at all reasonable times. The right to inspect the Association Records includes the right to make or obtain copies, at the reasonable expense, if any, of such member.

9. The Association shall maintain at the Condominium Property an adequate number of copies of the Declaration of Condominium, the Articles of Incorporation, these By-Laws, the Rules and Regulation adopted by the Association, and all amendments to each of the foregoing, as well as the Question and Answer Sheet required pursuant to the provisions of Section 718.504, Florida Statutes, to ensure their availability to members and prospective purchasers of units in the Condominium. The Association may charge the actual costs incurred by the Association in the preparation and furnishing of these documents to the parties requesting these documents.

10. The Association shall prepare a Question and Answer Sheet in accordance with the provisions of Section 718.504, Florida Statutes and shall update the Question and Answer Sheet annually.

E. The Treasurer shall:

1. Receive such monies as shall be paid into his hands for the accounts of the Association and disburse funds as may be ordered by the Board, taking proper vouchers for such disbursements, and be custodian of all securities, contracts, leases, and other important documents of the Association which he shall keep safely deposited.

2. Supervise the keeping of accounts of all financial transactions of the Association in books belonging to the Association. The Treasurer shall maintain all accounting records for the Association and for the Condominium, as may be required by Section 718.111(12)(a)11, Florida Statutes (the "Accounting Records"), for a period of not less than seven (7) years. The Accounting Records shall be maintained in St. Johns County, Florida and shall be open to inspection by any member, or the authorized representative of such member, at all reasonable times. The Treasurer shall prepare and distribute to all of the members of the Board of Directors, at least ten (10) days prior to each annual meeting of the Board of Directors, and whenever else required, a summary of the financial transactions and condition of the Association for the preceding year. The Treasurer shall make a full and accurate report of the matters and business pertaining to his office to the members at the annual meeting of members and make all reports required by law.

3. The Treasurer may have the assistance of an accountant or auditor, who shall be employed by the Board of Directors. In the event the Association enters into a management agreement, it shall be proper to delegate such of the Treasurer functions to the management agent as is deemed appropriate by the Board of Directors.

## VI MEMBERSHIP

A. Except as may be provided in the Articles of Incorporation, membership in the Association is limited to owners of condominium units in the Condominium. Membership is automatically conferred upon acquisition of a condominium unit in the Condominium, as evidenced by the filing of a deed of conveyance in the Public Records of St. Johns County, Florida or, as provided in the Declaration of Condominium, for transfer of membership upon the death of a member.

B. If a condominium unit is owned by more than one owner, co-partners or a corporation, there shall nevertheless be only one membership assigned to such unit, and the vote for such membership shall be cast by the person designated in a Voting Certificate signed by all of the owners (or by the proper corporate officer) of said unit, filed with the Secretary of the Association. In addition, only the voter designated in such Voting Certificate shall have the right to appoint a proxy. In the absence of such a writing, such vote shall not be counted; provided, however, that a Voting Certificate shall not be required when a unit is owned by a husband and his wife only.

C. Membership in the Association may be transferred only as an incident to the transfer of title to the condominium unit.

D. Membership shall terminate upon the transfer of title to a condominium unit.

VII  
MEETINGS, SPECIAL MEETINGS, QUORUMS, PROXIES

A. Meetings of Members.

1. Annual meetings: The annual meeting of the Association shall be held at the office of the Association on the first Thursday in December of each calendar year. At such meetings there shall be elected by ballot of the members, a Board of Directors, in accordance with the requirements of these By-Laws. The members may also transact such other business of the Association as may properly come before the meeting.

2. Special meetings: It shall be the duty of the President to call a special meeting of the members of the Association as directed by resolution of the Board of Directors or upon a petition signed by members having fifty-one (51%) percent of the total votes in the Association having been presented to the Secretary. No business shall be transacted at a special meeting except as stated in the notice thereof. In addition, a special meeting of the members of the Association, to recall or remove a member of the Board of Directors, shall be called upon members having at least ten (10%) percent of the total votes in the Association giving notice of the meeting, provided the notice states the purpose of the special meeting.

3. Notice of meetings: It shall be the duty of the Secretary to provide notice (which notice shall incorporate an identification of agenda items) of all meetings of members stating the purpose thereof as well as the time and place where it is to be held, to each member of record at each member's address as it appears on the membership book of the Association, or, if no address appears, at each member's last known place of address, at least fourteen (14) days but not more than forty (40) days prior to such meeting. Notice of all meetings of members shall be posted at a conspicuous place at the Condominium, at least fourteen (14) continuous days preceding the meeting, except in cases of emergency. The Board of Directors, upon notice to the members, shall by duly adopted rule designate a specific location on the Condominium Property upon which all notices of the meetings of the members shall be posted. If hand delivered, receipt of such notice shall be evidenced by receipt signed by the member. An officer of the Association shall provide an affidavit, to be included in the official records of the Association, affirming that notices of the Association meeting were mailed or hand delivered in accordance with provisions of Section 718.112(2)(d), Florida Statutes, to each member at the address last furnished to the Association. Notice of any meeting at which assessments against members are to be considered shall specifically contain a statement that such assessments will be considered and the nature of such assessments.

4. Budgetary meetings: The Board of Directors shall hand deliver to each unit owner, or mail to each unit owner, a meeting notice to the members of the Association indicating the date, time and place of the meeting together with a copy of the proposed annual budget, not less than fourteen (14) days prior to the meeting of the Board of Directors at which the budget will be considered.

Such meeting will be open to members. If an adopted budget requires assessment against the members in any fiscal or calendar year exceeding 115% of the assessments for the preceding year, the Board of Directors, upon written application of members having not less than 10% of the total votes in the Association, shall call a special meeting of the members within thirty (30) days, provided that not less than ten (10) days' written notice is given to each member. At the special meeting, members may consider and enact a budget by a vote of not less than 51% of the total votes in the Association. If a special meeting of members has been called and a quorum is not attained or a substitute budget is not adopted by the members, the budget adopted by the Board of Directors shall go into effect as scheduled. In determining whether assessments exceed 115% of similar assessments for prior years, any authorized provisions for reasonable reserves for repair or replacement of the property of the Condominium, anticipated to be incurred on a regular or annual basis, or assessments for betterments to the property of the Condominium shall be excluded from the computation.

5. Quorum: The presence, either in person or by proxy, of members having at least 25% of the total votes in the Association shall constitute a quorum for the transaction of business at all meetings of members. The written joinder of members may not be utilized to establish a quorum, when such joinder occurs subsequent to the meeting.

6. Adjourned meetings: If any meeting of members cannot be organized because a quorum has not attended, the members who are present, either in person or by proxy, may, except as otherwise provided for by law, adjourn the meeting to a time not less than 48 hours from the time the original meeting was called.

7. Voting: There shall be one (1) vote allocated to each Unit in the Condominium. The vote of members holding not less than a majority of the total votes of the Association present, either in person or by proxy, shall decide any question brought before any meeting of the membership of the Association, unless the question is one upon which, by express provision of statute or of the Declaration of Condominium, a different vote is required, in which case such express provision shall govern and control. All voting shall be by secret ballot.

8. Conduct of Meeting: All members shall have the right to participate at all meetings of the members of the Association with respect to all designated agenda items. Further, any member may tape record or videotape a meeting of the members of the Association.

9. Proxies: A member may appoint a proxy. Any proxy must be filed with the Secretary before the appointed time of each meeting and such proxy shall be valid only for the particular meeting designated in the proxy and any lawfully adjourned sessions thereof. In no event shall such proxy be valid for a period longer than ninety (90) days after the date of the first meeting for which it was given and every proxy shall be revocable, at any time, at the pleasure of the member granting it. Except as provided by the Act, a member may not vote by general proxy, but may vote by limited proxy substantially conforming to a limited proxy form adopted by the Division of Florida Land Sales,

Condominiums and Mobile Homes. Limited proxies and general proxies may be used to establish a quorum. Limited proxies shall be used for votes taken to waive or reduce reserves; for votes taken to waive financial statement requirements as provided by Section 718.111(14), Florida Statutes; for votes taken to amend the Declaration of Condominium pursuant to Section 718.110, Florida Statutes; for votes taken to amend the Articles of Incorporation or By-Laws; and for any other matter for which the Act requires a limited proxy. No proxy, limited or general, shall be used in the election of members to the Board of Directors. General proxies may be used for other matters for which limited proxies are not required, and may also be used in voting for non-substantive changes to items for which a limited proxy is required and given.

10. Waiver and consent: Nothing herein shall be construed to prevent a member from waiving notice of a meeting or acting by written agreement without a meeting, and such waiver and action by written agreement are hereby expressly permitted.

B. Meeting of Directors:

1. Organizational meeting: The first meeting of a newly elected Board of Directors shall be held within ten (10) days of election at such place as shall be fixed by the Directors at the meeting at which such Directors were elected. Notice of the first meeting of a newly elected Board of Directors shall be provided in accordance with the provisions of Section 718.112(2)(c), Florida Statutes.

2. Annual meetings: There shall be an annual meeting of the Board of Directors immediately prior to the annual meeting of the members, at the offices of the Association.

3. Regular meetings: The Board of Directors may establish a schedule of regular meetings to be held at such place as the Directors may designate, in which event no notice need be sent to the Directors once said schedule has been adopted. However, notice to Unit Owners of each Regular Meeting shall be given in accordance with Section 718.112(2)(c), Florida Statutes.

4. Special meetings: Special meetings of the Board of Directors may be called by the President, on three (3) days' notice to each Director, given personally or by mail, telephone or telegraph, which notice shall state the time, place and purpose of the meeting. Special meetings of the Board of Directors shall be called by the President or Secretary in like manner and on like notice upon the written request of at least two-thirds of the Board of Directors.

5. Notice to members: All meetings of the Board of Directors shall be open to all members. Any member may tape record or videotape meetings of the Board of Directors. In addition, the right to attend such meetings shall include the right to speak at such meetings with reference to all designated agenda items. Notice of the time and purpose (specifically incorporating an identification of agenda items) of all meetings of the Board of Directors shall be conspicuously posted at the

Condominium at least 48 continuous hours preceding the meeting, except in an emergency. However, written notice of any meeting of the Board of Directors at which non-emergency special assessments, or at which amendments to rules regarding unit use will be considered, shall be mailed or delivered to the members and posted conspicuously at the Condominium not less than fourteen (14) days prior to the meeting. Evidence of compliance with this fourteen (14) day notice shall be made by an affidavit executed by the person providing the notice and shall be filed among the official records of the Association.

Upon notice to the members, the Board of Directors shall, by duly adopted rule, designate a specific location on the Condominium Property upon which all notices of meetings of the Board of Directors shall be posted.

Meetings of a committee to take final action on behalf of the Board of Directors or to make recommendations to the Board of Directors regarding the budget are subject to the provisions of this section. Meetings of a committee that does not take final action on behalf of the Board of Directors or make recommendations to the Board of Directors regarding the budget are subject to the provisions of this section.

6. Waiver of Notice: Before or at any meeting of the Board of Directors, any Director may, in writing, waive notice of such meeting and such waiver shall be deemed equivalent to the giving of such notice. Attendance by a Director at any meeting of the Board of Directors shall be deemed a waiver of notice by him of the time and place thereof, unless such Director attends a meeting for the sole purpose of objecting to the propriety of the notice provided to him.

7. Voting at meetings: A Director who is present at a meeting of the Board of Directors at which action on any corporate matter is taken shall be presumed to have assented to the action taken unless such Director votes against such action or abstains from voting in respect thereto because of an asserted conflict of interest. Directors may not vote by proxy or by secret ballot at meetings of the Board of Directors. A vote or abstention for each Director present at a meeting of the Board of Directors shall be recorded in the minutes of such meeting.

8. Quorum: At all meetings of the Board of Directors, a majority of the Directors shall constitute a quorum for the transaction of business, and the acts of the majority of the Directors present at a meeting at which a quorum is present shall be the acts of the Board of Directors. If, at any meeting of the Board of Directors, there be less than a quorum, the majority of those present may adjourn the meeting from time to time. At any such adjourned meeting, any business which might have been transacted at the meeting as originally called may be transacted without further notice.

**VIII**  
**PROCEDURE**

Roberts Rules of Order (latest edition) shall govern the conduct of corporate proceedings when not in conflict with the Declaration of Condominium, the Articles of Incorporation, these By-Laws or applicable Florida law.

**IX**  
**ASSESSMENTS AND MANNER OF COLLECTION**

A. The Board of Directors has the sole power to and shall from time to time fix and determine the amounts necessary to pay the common expenses of the Condominium and the Association. The common expenses include those expenses described in the Declaration of Condominium and any other expenses designated as common expenses by the Board of Directors, under the authority and sanction of the Declaration of Condominium and the Act.

B. The Board shall adopt a budget for the Association and the Condominium during the month preceding the fiscal year wherein the budget will take effect, which budget shall include a schedule of assessments to be paid by the members.

C. Each Member shall be responsible for the payment of the assessments imposed against such member's unit in an amount equal to the percentage of responsibility for payment of common expenses provided in the Declaration of Condominium.

D. Regular assessments shall be paid by the members on a monthly basis, payable on the first day of each and every month.

E. Special assessments, should they be required by the Board of Directors, shall be levied and paid in the same manner as regular assessments, unless the Declaration of Condominium shall otherwise provide, or unless the Board of Directors determines otherwise.

F. When the Board of Directors has determined the amount of any assessments, the Secretary shall transmit a statement of such assessment to each member. Until further notice, assessments shall be made payable to the Association and shall be payable at the office of the Association.

Assessments are necessarily made upon projections and estimates of the Board of Directors, and may be in excess of, or be less than, the sums required to meet the cash requirements of the Condominium and the Association, in which event the Board of Directors may increase or diminish the amount of an assessment and make such adjustments in cash, or otherwise as they shall deem



proper, in their sole discretion, including the assessment of each member of such member's proportionate share for any deficiency. Notice of all changes in assessments shall be given to all members.

G. The failure to pay any assessment within five (5) days from the date due shall entitle the Association to levy a late charge against the delinquent member for each thirty (30) day period that the assessment remains delinquent in an amount not to exceed the greater of \$25.00 or five percent (5%) of the assessment.

H. In the event an assessment is not paid within ten (10) days of the date same shall be due and payable, the Association, through the Board of Directors, may, proceed to enforce and collect said assessments from the delinquent member in any manner provided for by the Act, the Declaration of Condominium and these By-Laws. Each member shall be individually responsible for the payment of assessments against his unit and for the payment of reasonable attorneys' fees and costs incurred by the Association in the collection of sums due and the enforcement of any lien held by the Association.

I. If the proposed annual budget is not adopted prior to the start of the new fiscal year, an assessment shall be presumed to be made in the amount of the last prior assessment and monthly installments on such assessment shall be due upon each installment payment date until changed by an amended assessment.

## X

### FISCAL MATTERS

A. Fiscal year: The fiscal year of the Association shall end on December 31st of each year.

B. Depositories: The funds of the Association shall be deposited in a savings and loan association or a bank, in an account for the Association under resolutions duly approved by the Board of Directors, and shall be withdrawn only over the signature of the authorized Officers. Said funds shall be used only for Association purposes.

C. Association Funds: All funds of the Association shall be maintained separately in the name of the Association. Reserve and operating funds of the Association shall not be commingled unless combined for investment purposes. However, such funds must be accounted for separately, and the combined account balance may not, at any time, be less than the amount identified as reserve funds in the combined accounts. All such funds shall be maintained in accounts at a financial institution as defined in Section 655.005, Florida Statutes and no agent, employee, officer or director of the Association shall commingle any funds of the Association with such person's funds or with the funds of any other condominium association or with the funds of any community association as defined in Section 468.431, Florida Statutes.

D. Fidelity bonds: The Association shall obtain and maintain adequate insurance or fidelity bonding for all persons who control or disburse Association funds. The insurance policy or fidelity bond must cover the maximum funds that will be in the custody of the Association or its management agent at any one time. "Persons who control or disburse funds of the Association" includes, but is not limited to, those persons authorized to sign checks and the President, Vice-President, Secretary and Treasurer of the Association. The premium for such insurance or bonds shall be paid for by the Association.

E. Records: The Association shall maintain accounting records according to good accounting practice, which records shall be open to inspection by members at reasonable times. Such records shall include a record of receipts and expenditures for each member which shall designate the name and address of the member, the amount of each assessment, the amounts paid upon the account and the balance due, in a register of names for the benefit of any mortgage holders or lien holders who have notified the Association of their liens, and to which lien holders the Association will give notice of default, if requested.

F. Annual report: An annual report of the accounts of the Association shall be made annually by an auditor, accountant or Certified Public Accountant and a copy of the financial statement obtained from such annual report shall be furnished to each member no later than the first day of April following the fiscal year for which the report is made. The report shall be deemed to be furnished to the member upon its delivery or by mailing to the member at his last known address as shown on the books and records of the Association.

G. Insurance: The Association shall procure, maintain and keep in full force and effect, all insurance required by the Declaration of Condominium.

## XI

### ADMINISTRATIVE RULES AND REGULATIONS

The Board of Directors may, from time to time, adopt rules and regulations governing the details of the operation and use of the common elements of the Condominium, and such other rules and restrictions as are designed to prevent unreasonable interference with the use of the units and the common elements by the members and all members shall abide thereby, provided that said rules and regulations shall be equally applicable to all members and uniform in their application and effect.

## XII

### VIOLATION AND DEFAULTS

In the event of a violation, other than non-payment of an assessment by a member, of any of the provisions of the Declaration of Condominium, these By-Laws, the Rules and Regulations of the Association, the Articles of Incorporation or any provision of the Act, the Association, after reasonable notice to cure not to exceed ten (10) days, shall have all rights and remedies provided by law, including

without limitation (and such remedies shall or many be cumulative) the right to sue for damages, the right to seek injunctive relief, and in the event of the failure to pay assessments, the right to foreclose its lien provided in the Act and in every such proceeding, the prevailing party shall be liable for court costs and the Association's reasonable attorney's fees. If the Association elects to enforce its lien by foreclosure, the Association, provided the member has remained in possession of the unit, shall be entitled to petition a court of competent jurisdiction for payment of a reasonable rental from such member from the date on which the payment of any assessment became delinquent and the Association shall be entitled to the appointment of a receiver to collect such rent. A suit to collect unpaid assessments may be prosecuted by the Association without waiving the lien securing such unpaid assessments.

**XIII**  
**AMENDMENT OF BY-LAWS**

Subject always to the provisions of the Declaration of Condominium, these By-Laws may be amended, modified or rescinded in accordance with the Declaration of Condominium or by a resolution duly adopted by a majority of the Board of Directors at any duly called meeting of the Board of Directors, and thereafter submitted to the members at any duly convened meeting of the members and approved by members, present in person or by proxy, having at least 66% of the votes at the meeting, provided that notice of the proposed amendment (unless waived) is given in the notice of the meeting, and further provided that the voting requirements of the Declaration of Condominium are met in full, in the appropriate cases. Amendments to these By-Laws may be proposed by the Board of Directors, acting upon the vote of a majority of the Directors, or proposed by members of the Association having a majority of the total votes in the Association.

No amendment shall discriminate against any unit owner nor any class or group of unit owners unless the unit owners so affected shall consent. No amendment shall be made that is in conflict with the Articles of Incorporation or the Declaration of Condominium. No By-Law shall be revised or amended by reference to its title or number only. Proposals to amend existing By-Laws shall contain the full text of the By-Laws to be amended; new words shall be inserted in the text and underlined and words to be deleted shall be lined through with hyphens. However, if the proposed change is so extensive that this procedure would hinder, rather than assist, the understanding of the proposed amendment, it is not necessary to use underlining and hyphens as indicators of words added or deleted but, instead, a notation must be inserted immediately preceding the proposed amendment in substantially the following language: Substantial rewording of By-Law. See By-Law Article \_\_\_ for present text. Non-material errors or omissions in the By-Law process shall not invalidate an otherwise properly promulgated amendment.

A copy of each amendment shall be attached to a certificate stating that the amendment was duly adopted as an amendment of the By-Laws, which certificate shall be executed by the Officers of the Association with the formalities of a deed. Each amendment to the By-Laws must set forth, on the first page thereof, the book and page of the public records where the Declaration of Condominium has

been recorded. The amendment shall be effective when such certificate and a copy of the amendment are recorded in the Public Records of St. Johns County, Florida.

**XIV**  
**VALIDITY**

If any portion of the By-Laws shall be adjudged invalid, such fact shall not affect the validity of any other By-Laws.

COPY