

Prepared by and return to:
Brian Belt
Shutts & Bowen LLP
201 South Biscayne Boulevard
Suite 1500
Miami, Florida 33131

DECLARATION OF CONDOMINIUM
OF
HERITAGE DEERWOOD, A CONDOMINIUM

180
1/12/06

TABLE OF CONTENTS

	<u>Page No.</u>
1. INTRODUCTION AND SUBMISSION TO CONDOMINIUM	1
2. NAME - PLAN OF DEVELOPMENT	1
3. NAME OF ASSOCIATION	1
4. DEFINITIONS.....	2
5. CONDOMINIUM UNITS, BOUNDARIES, AND APPURTENANCES.....	7
6. COMMON ELEMENTS AND COMMON SURPLUS; VOTING RIGHTS.....	14
7. MAINTENANCE	14
8. ALTERATIONS, ADDITIONS AND IMPROVEMENTS	15
9. ADMINISTRATION, POWERS AND DUTIES AND FISCAL MANAGEMENT.....	18
10. DETERMINATION OF COMMON EXPENSES AND FIXING OF ASSESSMENTS THEREFOR	21
11. COLLECTION OF ASSESSMENTS.....	21
12. INSURANCE.....	24
13. RECONSTRUCTION OR REPAIR AFTER CASUALTY	29
14. CONDEMNATION.....	31
15. USE RESTRICTIONS.....	33
16. LEASE, CONVEYANCE, DISPOSITION.....	35
17. COMPLIANCE AND DEFAULT	38
18. AMENDMENTS	39
19. TERMINATION.....	41
20. PROVISIONS PERTAINING TO THE DECLARANT.....	43
21. RIGHTS OF MORTGAGEES.....	45
22. ASSOCIATION AGREEMENTS	46
23. DISCLAIMER OF WARRANTIES.....	46
24. INDEMNIFICATION OF OFFICERS AND DIRECTORS.....	47
25. ACCESS MONITORING.....	47
26. SEVERABILITY AND NON-WAIVER	48

DECLARATION OF CONDOMINIUM

OF

HERITAGE DEERWOOD, A CONDOMINIUM

Heritage Deerwood Condominium, LLC, a Delaware limited liability company (the "Declarant"), on behalf of itself and its successors, grantees, and assigns, hereby makes this Declaration of Condominium:

1. INTRODUCTION AND SUBMISSION TO CONDOMINIUM.

1.1. INTRODUCTION. The Declarant owns the fee simple title to certain land located within the City of Jacksonville, Duval County, Florida, as more particularly described in Exhibit A attached hereto (the "Property").

1.2. SUBMISSION TO CONDOMINIUM. The Declarant hereby submits the following property to the condominium form of ownership and use in the manner provided for in the Condominium Act:

1.2.1. the Property, together with all improvements erected or to be erected thereon;

1.2.2. all other property, real, personal or mixed, now or hereafter situated on or within the Property; and

1.2.3. the Units and the Common Elements now or hereafter situated on the Property; provided, however, excluding all cable television, cellular phone antennae and other utility installations or equipment owned by a cable television, telecommunication, cellular phone or utility provider which have contracted with or have imposed other legal requirements upon the Declarant or the Association to provide a utility or telecommunication service and/or equipment. The Units and Common Elements are hereby declared to be subject to the restrictions, easements, conditions and covenants contained in this Declaration of Condominium governing the use of the Units and Common Elements and prescribing the obligations and responsibilities incident to ownership of each Unit and its appurtenant Limited Common Elements and undivided interest in Common Elements.

2. NAME - PLAN OF DEVELOPMENT. The Condominium consists of twenty-seven (27) residential buildings and one (1) clubhouse (each individually a "Building" and collectively, the "Buildings"). The residential Buildings contain a total of two hundred ten (210) residential condominium units and associated improvements (individually, a "Unit" and collectively, the "Units"). The name of the Condominium is "Heritage Deerwood, a Condominium."

3. NAME OF ASSOCIATION. The name of the condominium association responsible for the operation of the Condominium is "Heritage Deerwood Condominium Association, Inc.," a Florida not-for-profit corporation.

4. DEFINITIONS. The terms used herein will have the meanings stated in the "Condominium Act" (subsequently defined) unless otherwise defined below, or unless the context otherwise requires:

4.1. "**Articles of Incorporation**" or "**Articles**" - The Articles of Incorporation for the Association, as amended from time to time. A copy of the Articles of Incorporation is attached to this Declaration as Exhibit C.

4.2. "**Assessment**" - The share of the funds required for the payment of Common Expenses that are from time-to-time assessed against a Unit Owner.

4.3. "**Association**" - Heritage Deerwood Condominium Association, Inc., a Florida not-for-profit corporation responsible for the operation of the Condominium, and its successor(s).

4.4. "**Association Property**" - All real and personal property owned or leased by the Association.

4.5. "**Board of Directors**", "**Board**" or "**Directors of Board**" - The board of directors responsible for the administration of the Association, referred to in the Condominium Act as the board of administration.

4.6. "**Building**" or "**Buildings**" - The structures in which the Units and the Common Elements are located, regardless of the number of such structures, which are located on the Property.

4.7. "**By-Laws**" - The By-Laws of the Association, as amended from time to time. A copy of the By-Laws is attached to this Declaration as Exhibit D.

4.8. "**Capital Improvement Assessment**" - A charge against a Unit Owner and the Unit Owner's Unit, representing a portion of the costs incurred by the Association for the acquisition, installation, construction or replacement (as distinguished from repairs and maintenance) of any capital improvements located or to be located within the Common Elements or Association Property.

4.9. "**Charge or Special Charge**" - The obligation of a Unit Owner to pay or reimburse money to the Association that cannot be secured as an Assessment pursuant to Section 718.116 of the Condominium Act, but which will, if the charge is not paid, give rise to a cause of action against the Unit Owner pursuant to this Declaration.

4.10. "**Common Elements**" - "Common Elements" means and includes:

4.10.1. the Property;

4.10.2. the portions of the Condominium Property not included within the Units, including, but not limited to, (i) any other land or interests in land which may be included in the Condominium Property, whether or not contiguous; and (ii) all improvements and parts thereof which are not included within the Units;

4.10.3. easements over, under, across and through Units for conduits, ducts, plumbing, wiring and other facilities for the furnishing of utility and other services to Units and the Common Elements and/or the Condominium Property;

4.10.4. easements of support in every portion of a Unit which contributes to the support of any other Unit or the Building in which such Unit is located;

4.10.5. the property and installations required for the furnishing of utilities and services to more than one Unit or to the Common Elements and/or the Condominium Property; and

4.10.6. any other parts of the Condominium Property designated as Common Elements in this Declaration or the Condominium Act.

Reference in this Declaration to Common Elements shall include all Limited Common Elements unless the context would otherwise dictate.

4.11. **“Common Expenses”** - All expenses incurred by the Association for the operation, maintenance, repair, replacement or protection of the Common Elements and the Association Property for which the Unit Owners are liable to the Association, and any other expense designated as a “Common Expense” by the Condominium Act, this Declaration, the Articles of Incorporation, or the By-Laws. For purposes of this Declaration, “Common Expenses” shall also include, without limitation: (a) all reserves for Common Elements required by the Condominium Act or otherwise established by the Association, regardless of when reserve funds are expended; (b) the cost of a master antenna television system, a duly franchised cable television service or any broadband, telecommunication, satellite and/or internet service; (c) if applicable, costs relating to reasonable transportation services, insurance for directors and officers, road maintenance and operation expenses, in-house and/or interactive communications and surveillance systems; (d) the cost of any bulk contract for broadband, telecommunication satellite and/or internet services, if any; (e) the real property taxes and other maintenance expenses attributable to any Association Property; (f) any unpaid share of Common Expenses or Assessments extinguished by foreclosure of a superior lien or by deed in lieu of foreclosure; (g) the costs of carrying out the powers and duties of the Association; (h) insurance premiums as described in Section 12; (i) legal and accounting fees, management fees and compensation and operating expenses of the Common Elements; (j) the Assessments and other maintenance expenses attributable to any Units acquired by the Association; (k) charges for utilities, water, sewer, waste, natural gas and cable used in common for the benefit of the Condominium or if not separately metered for each Unit and any bulk metered or bulk calculated utility services rendered to the Condominium Property or the Units for their benefit; (l) cleaning and janitorial services of the Common Elements; and (m) any other expenses designated from time to time by the Board of Directors as Common Expenses which are not inconsistent with the Condominium Act. Common Expenses shall not include any separate obligations of individual Unit Owners.

4.12. **“Common Surplus”** - The excess of all receipts of the Association collected on behalf of the Association from the Owners of Units over and above the amount of Common Expenses.

4.13. **"Condominium"** - Heritage Deerwood, a Condominium, the condominium created by this document.

4.14. **"Condominium Act"** - Chapter 718, Florida Statutes, in its form as of the date of this Declaration, and as it may hereafter be renumbered. All references to Chapter 718, Florida Statutes, or any section or subsection thereof shall be deemed to refer to such Chapter, section or subsection in its form as of the date of this Declaration, and as it may hereafter be renumbered.

4.15. **"Condominium Documents"** - This Declaration and the attached exhibits, as same may be amended from time to time.

4.16. **"Condominium Parcel"** - A Unit, together with the undivided share in the Common Elements which are appurtenant to the Unit.

4.17. **"Condominium Property"** - The real and personal property (including, the Property), both tangible and intangible, subject to condominium ownership, whether or not contiguous; all improvements thereon; and all easements and rights appurtenant thereto intended for use in connection with the Condominium.

4.18. **"Condominium Plot Plan"** - The condominium drawings required by Section 718.104 of the Condominium Act as amended from time-to-time. A copy of the Condominium Plot Plan is attached to this Declaration as Exhibit B and made a part hereof.

4.19. **"County"** - The County of Duval, State of Florida.

4.20. **"Declaration"** or **"Declaration of Condominium"** - This Declaration of Condominium and all exhibits attached hereto, as it may be amended from time to time.

4.21. **"Declarant"** Heritage Deerwood Condominium, LLC, a Delaware limited liability company, its successors and such of its assigns as to which the rights of Declarant hereunder are specifically assigned. Declarant may assign all or a portion of its rights hereunder, or all or a portion of such rights in connection with specific portions of the Condominium. In the event of any partial assignment, the assignee shall not be deemed the Declarant, but may exercise such rights of Declarant as are specifically assigned to it. Any such assignment may be made on a nonexclusive basis. Notwithstanding any assignment of the Declarant's rights hereunder (whether partially or in full), the assignee shall not be deemed to have assumed any of the obligations of the Declarant unless, and only to the extent that, it expressly agrees to do so in writing. The rights of Declarant under this Declaration are independent of the Declarant's rights to control the Board of Directors of the Association, and, accordingly, shall not be deemed waived, transferred or assigned to the Unit Owners, the Board or the Association upon the transfer of control of the Association.

4.22. **"Division"** - The Division of Florida Land Sales, Condominiums and Mobile Homes of the Department of Business and Professional Regulation, State of Florida, or its successor.

4.23. **“Exhibits”**

- A. Legal Description of the Property;
- B. Survey and Condominium Plot Plan;
- C. Association Articles of Incorporation; and
- D. Association By-Laws.
- E. Allocated Interests

The foregoing Exhibits are hereby incorporated into this Declaration by reference thereto.

4.24. **“Extraordinary Financial Event”** shall have the meaning given to it in Section 11.1 below.

4.25. **“Family”** - One natural person or a group of two or more natural persons, each of whom is related to each of the others by blood, marriage, or adoption (exclusive of household servants); or not more than two adult persons not so related and the children of either or both of them who reside together as a single not-for-profit housekeeping unit.

4.26. **“First Mortgagee”** - The mortgagee or its assignee of a first mortgage on a Condominium Parcel.

4.27. **“Guest”** - Any person who is physically present in or occupies a Unit on a temporary basis at the invitation of the Unit Owner without the payment of consideration.

4.28. **“Institutional First Mortgagee”** - A bank, savings and loan association, insurance company, real estate or mortgage investment trust, pension fund, an agency of the United States Government, mortgage banker, the Federal National Mortgage Association (“FNMA”), the Federal Home Loan Mortgage Corporation (“FHLMC”) or any other lender generally recognized as an institutional lender, or the Declarant, holding a first mortgage on a Unit or Units.

4.29. **“Insurance Trustee”** - The term “Insurance Trustee” shall have the meaning ascribed to such term in Section 12.8.

4.30. **“Insured Property”** - The term “Insured Property” has the meaning ascribed to such term in Section 12.2.1.

4.31. **“Lease”** - The grant by a Unit Owner of a temporary right of use of a Unit.

4.32. **“Lessee”** - The person or persons, entity or entities, who are the lessees under a Lease of any part or all of a Unit. All such leased property is referred to as the “Leased Premises.” Lessees shall not be Members of the Association, but shall, through the Unit Owner, be entitled to certain rights and undertake certain obligations with respect to the Unit. Such rights and obligations are appurtenant to the Lessee’s lease of the Leased Premises.

4.33. **“Limited Common Elements”** - Those Common Elements, the use of which is reserved to a certain Unit or Units to the exclusion of the other Units, as same are shown on the Condominium Plot Plan or are specified in this Declaration. A Limited Common Element is appurtenant to the specific Unit to which it is assigned and includes, without limitation, balconies

and those portions of driveways located adjacent to a Unit's garage and between the garage and the street or private drive or roadway. Except as set forth in Exhibit B, in the event of any reasonable doubt or dispute as to whether any portion of the Common Elements constitutes a Limited Common Element, or in the event of any question as to which Units are served thereby, a decision shall be made by a majority vote of the Board of Directors of the Association and shall be binding and conclusive when so made; provided, however, this provision shall not affect Common Elements or Limited Common Elements identified as such in Exhibit B to this Declaration.

4.34. **"Member"** - Each Unit Owner who is a member of the Association. Notwithstanding the foregoing, each Unit shall have one (1) indivisible vote that may be cast at meetings of the Members pursuant to the terms of the By-Laws of the Association attached to this Declaration as Exhibit D.

4.35. **"Occupant"** - A person (be it an Owner or a Lessee) who resides in a Unit. Where the context dictates, an Occupant shall also be deemed to include the family members, Guests, licensees and invitees.

4.36. **"Optional Property"** - The term "Optional Property" has the meaning ascribed to such term in Section 12.8.2.

4.37. **"Operation"** - The administration and management of the Condominium Property.

4.38. **"Person"** - An individual, corporation, partnership, trust, or other legal entity capable of holding title to real property.

4.39. **"Primary Institutional First Mortgagee"** - The First Mortgagee which owns, at the relevant time, Unit mortgages securing a greater aggregate indebtedness than is owed to any other First Mortgagee.

4.40. **"Property"** - That certain real property as described in Exhibit A to this Declaration.

4.41. **"Rules and Regulations"** - The Rules and Regulations of the Association, as amended from time-to-time.

4.42. **"Special Assessment"** - A charge against a Unit Owner and the Unit Owner's Unit, representing a portion of the costs incurred by the Association for specific purposes of a nonrecurring nature which are not in the nature of capital improvements.

4.43. **"Termination Trustee"** - The term "Termination Trustee" shall have the meaning ascribed to such term in Section 19.3.1.

4.44. **"Unit"** - That portion of the Condominium Property which is subject to exclusive fee simple ownership. The term "Unit," where the context so requires or admits, is often used synonymously in this Declaration with "Condominium Parcel" when meaning the Unit and all appurtenances to the Unit.

4.45. **"Unit Owner"** - The record owner of legal title to a Condominium Parcel.

4.46. **"Very Substantial Damage"** - The term "Very Substantial Damage" shall have the meaning ascribed to such term in Section 13.1.

4.47. **"Voting Interest"** - The voting rights distributed to the Association members pursuant to Section 718.104(4)(i) of the Condominium Act.

Whenever the context permits, use of the plural includes the singular, use of the singular includes the plural, and use of any gender includes all genders.

5. CONDOMINIUM UNITS, BOUNDARIES, AND APPURTENANCES. Each Unit and its appurtenances (including an undivided interest in the Common Elements and any right to use any Limited Common Elements) constitute a separate parcel of real property that may be owned in fee simple. The Unit may be conveyed, transferred, and encumbered like any other parcel of real property, independently of all other parts of the Condominium Property, subject only to the provisions of the Condominium Documents and applicable laws.

5.1. **SURVEY AND PLOT PLAN.** Attached to this Declaration as Exhibit B is a survey of the land, a graphic description of the improvements and a plot plan of the Condominium. Exhibit B identifies the two hundred ten (210) Units in the Condominium, the twenty-eight (28) Buildings, the Common Elements, the Limited Common Elements and their relative locations and approximate dimensions.

5.2. **UNIT IDENTIFICATION.** Each Unit and Building is separately identified by a number as shown on the Condominium Plot Plan attached to this Declaration as Exhibit B. The first digit of a three digit Unit number and the first and second digits of a four digit Unit number represent the number of the residential Building in which the Unit is located. The last digit of a Unit number represents the particular Unit in each residential Building. If more than one Unit in the Building is acquired by the same Owner and such Units are contiguous to one another and such Owner desires to combine such Units into a single Unit, the approval of such Owner, the Owner of the Units to be combined, the record owner(s) of liens on the Units to be combined and the members of the Association owning not less than seventy-five percent (75%) of the Units shall be required prior to such a modification; provided, however, that so long as the Declarant shall own any Unit, approval of the record owner of liens on the Declarant owned Units and the members of the Association owning fifty-one percent (51%) or more of the Units shall be required prior to such modification.

5.3. **NO SUBDIVISION OF UNIT.** Except as expressly stated to the contrary in this Declaration, no Unit may be divided or subdivided, nor in any manner made into a smaller Unit than that Unit as shown on Exhibit B.

5.4. **NO SEPARATION OF COMMON ELEMENTS OR LIMITED COMMON ELEMENTS.** Neither any undivided interest in the Common Elements declared to be an appurtenance to a Unit or Units nor the use of any parcel of Limited Common Elements, may be transferred, conveyed, devised or encumbered separately from the Unit(s) to which it is appurtenant.

5.5. CONVEYANCE ETC. OF UNIT. The transfer, conveyance, devise or encumbrance of a Unit shall be deemed to include in the transfer, conveyance, devise or encumbrance, the (a) undivided interest in the Common Elements and the Common Surplus appurtenant to the Unit, (b) the use rights in any Limited Common Elements appurtenant to the Unit, even though such undivided interest in Common Elements or rights in any parcel of Limited Common Elements are not expressly described in the instrument conveying, devising or encumbering the Unit, (c) an exclusive easement for the use of the airspace occupied by the Unit as it exists at any particular time and as the Unit may lawfully be altered or reconstructed from time-to-time, (d) membership in the Association with the full voting rights appurtenant thereto, and (e) other appurtenances as may be provided by this Declaration. Any instrument purporting to transfer, convey or encumber any Unit or its appurtenant interest in Common Elements or appurtenant rights in any parcel of Limited Common Elements separately or otherwise than as a unitary Condominium Parcel shall be null and void insofar as it purports to affect any interest in the Unit and its appurtenant undivided interest in Common Elements and any appurtenant Limited Common Element. Any instrument transferring, conveying, devising, encumbering or otherwise dealing with any Unit which describes said Unit by its designation assigned in Exhibit B without limitation or exception, shall affect the entire Unit and its appurtenant undivided interest in Common Elements and appurtenant rights in any Limited Common Elements. Nothing contained in the Condominium Documents shall be construed as prohibiting ownership of any Unit and its appurtenant undivided interest in Common Elements and any appurtenant Limited Common Elements by more than one person or entity as tenants in common, joint tenants or as tenants by the entireties.

5.6. BOUNDARIES. Each Unit shall include that part of the Building containing the Unit that lies within the boundaries as defined below. The boundaries may exist now or may be created by construction, settlement, or movement of the Building; or by permissible repairs, reconstruction, or alterations.

5.6.1. UPPER AND LOWER BOUNDARIES. The upper and lower boundaries of each Unit will be:

5.6.1.1. Upper Boundaries. The horizontal plane of the unfinished lower surface of the ceiling (which will be deemed to be the ceiling of the upper story if the Unit is a multi-story Unit, provided that in multi-story Units where the lower boundary extends beyond the upper boundary, the upper boundary shall include that portion of the ceiling of the lower floor for which there is no corresponding ceiling on the upper floor directly above such bottom floor ceiling).

5.6.1.2. Lower Boundaries. The horizontal plane of the unfinished upper surface of the floor of the Unit (which will be deemed to be the floor of the first story if the Unit is a multi-story Unit, provided that in multi-story Units where the upper boundary extends beyond the lower boundary, the lower boundary shall include that portion of the floor of the upper floor for which there is no corresponding floor on the bottom floor directly below the floor of such top floor).

5.6.1.3. Interior Divisions. Except as provided in subsection 5.6.1.1 and subsection 5.6.1.2 above, no part of the floor of the top floor, ceiling of the bottom floor, in all

cases of a multi-story Unit, if any, or nonstructural interior walls shall be considered a boundary of the Unit; provided however structural slabs between floors of a multi-story Unit are not part of the Unit and are considered Common Elements.

5.6.2. PERIMETER BOUNDARIES. The perimeter boundaries of the Unit shall be the vertical planes of the unfinished interior surfaces of the drywall walls bounding the Unit extended to their planar intersections with each other and with the upper and lower boundaries as shown on the Condominium Plot Plan attached as Exhibit B to this Declaration.

5.6.3. APERTURES. Where there are apertures in any boundary, including, but not limited to, windows, doors, bay windows and skylights, such boundaries shall be extended to include the windows, doors, skylights and other fixtures located in such apertures, including all frameworks, window casings and weather stripping thereof, together with exterior surfaces made of glass or other transparent materials.

5.6.4. EXCEPTIONS. In cases not specifically covered above, and/or in any case of conflict or ambiguity, the Condominium Plot Plan of the Units set forth as Exhibit "B" to this Declaration shall control in determining the boundaries of a Unit, except that the provisions of Section 5.6.3 above shall control unless specifically depicted and labeled otherwise on such survey.

5.6.5. AIR CONDITIONING EQUIPMENT AND WATER HEATERS. Air conditioning equipment and water heaters, if any, serving a particular Unit and no others and installed on any part of the Common Elements shall be a part of the Unit which that equipment serves.

5.7. EXCLUSIVE USE. Each Unit Owner will have the exclusive use of such Unit Owner's Unit.

5.8. OWNERSHIP. The ownership of each Unit will carry with it, as appropriate, and whether or not separately described, all of the rights, title, and interest of a Unit Owner in the Condominium Property which will include, but not be limited to:

5.8.1. An undivided share of ownership of the Common Elements and Common Surplus.

5.8.2. Either the exclusive use or use in common with one or more other designated Units of the Limited Common Elements that may exist.

5.8.3. Membership in the Association and voting rights.

5.8.4. An exclusive easement for the use of the air space occupied by the Unit as it exists at any particular time and as the Unit may be lawfully altered or reconstructed from time to time. The easement will be terminated automatically in any air space that is vacated from time to time.

5.9. EASEMENTS. Each of the following easements is a covenant running with the land as to the Condominium.

5.9.1. UTILITIES. Declarant hereby reserves unto itself and its successors and assigns, and grants to the respective utility providers and their successors and assigns, non-exclusive easements under, through and over the Condominium and the Property as may be required from time to time for the construction, use and maintenance of all utilities (whether public or private), cable television, communications, security systems and other services as may be required to serve the Condominium; provided, however, that these easements shall not materially and adversely interfere, on a permanent basis, with the residential use of the Units. Declarant also hereby reserves unto itself and its successors and assigns, and grants to the Association (with the power to assign), a non-exclusive easement over and across the Common Elements for the purpose of providing drainage and for the installation, operation, use and maintenance of drainage facilities; provided, however, that the Association shall be responsible for the continuous maintenance of the easements of the drainage system located on any and all portions of the Condominium Property. The Association shall have a right of access during reasonable hours to each Unit to maintain, repair or replace any elements providing such services and to remove any improvements interfering with such facilities; provided that, except in the case of emergencies, entry shall not be made without reasonable notice (one (1) day's notice or attempted notice shall be deemed reasonable, except that notice shall not be required if the Unit Owner is absent when the giving of notice is attempted). A Unit Owner shall do nothing within or outside the Unit Owner's Unit that interferes or impairs, or may interfere or impair, the provision of such utility, cable television, communications and security systems and other services and drainage facilities or the use of these easements.

5.9.2. TRAFFIC. Declarant hereby reserves unto itself and its successors and assigns, and grants to the Association and each Unit Owner, resident and Guest, a non-exclusive easement for pedestrian traffic over, through and across sidewalks, streets, driveways, paths, walks, hallways, lobbies and other portions of the Common Elements as may be from time to time intended and designated for such use and for vehicular and pedestrian traffic over, through and across, and parking on, such portions of the Common Elements as may, from time to time be paved and intended for such purposes. No such easement shall be encumbered by any leasehold or lien other than those on Units and any such lien automatically shall be subordinate to the rights of Unit Owners and the Association with respect to such easements.

5.9.3. SUPPORT. An easement is granted and reserved in every portion of a Unit and the Common Elements contributing to the support of the Building structures or any part thereof for the benefit of all Units and the Common Elements so supported.

5.9.4. PERPETUAL NON-EXCLUSIVE EASEMENT IN COMMON ELEMENTS. Declarant hereby reserves unto itself and its successors and assigns, and grants to the Association, its successors and assigns, a perpetual, non-exclusive easement in the Common Elements for all proper and normal purposes, and for the furnishing of services and facilities for which the same are reasonably intended. An easement appurtenant to each Unit is granted and reserved over such portions of the Common Elements as shall be reasonably required to gain access to air conditioning equipment serving that Unit for the purpose of servicing, maintaining and repairing the equipment.

5.9.5. ENCROACHMENTS. If (a) any portion of the Common Elements encroaches upon any Unit (or Limited Common Element appurtenant thereto); (b) any Unit (or

Limited Common Element appurtenant thereto) encroaches upon any other Unit (or Limited Common Element appurtenant thereto) or upon any portion of the Common Elements; (c) any encroachment shall hereafter occur as a result of (i) construction of the Buildings and other Common Elements; (ii) settling or shifting of the Buildings or other Common Elements; (iii) any alteration or repair to the Common Elements made by or with the consent of the Association or the Declarant, as appropriate, or (iv) any repair or restoration of the improvements to the Condominium (or any portion thereof) or any Unit after damage by fire or other casualty or any taking by condemnation or eminent domain proceedings of all or any portion of any Unit or the Common Elements, then, in any such event, a valid easement shall exist for such encroachment and for the maintenance of same so long as the improvements to the Condominium shall stand.

5.9.6. CONSTRUCTION; MAINTENANCE. The Declarant (including its affiliates and its and their respective designees, contractors, successors and assigns) shall have the right, in its (and their) sole discretion from time to time, to enter the Condominium Property and take all other action necessary or convenient for the purpose of completing the construction of the Condominium, or any part thereof, or any improvements, structures, facilities and/or Units located or to be located on the Condominium Property, and/or any improvements to be located adjacent thereto, and for repair, replacement and maintenance for warranty purposes where the Declarant, in its sole discretion, determines that it is required or desires to do so.

5.9.7. SALES ACTIVITY. For as long as there are any Units owned or leased by the Declarant and/or the Declarant (or an affiliate) is marketing Units for sale or lease, the Declarant, for itself and its designees, successors and assigns, shall have the right to use any Unit (or Units leased by the Declarant or its designee) and parts of the Common Elements or Condominium Property for guest accommodations, model apartments and sales, construction, leasing, administration and development offices or sales centers, to show model Units and the Common Elements to prospective purchasers and tenants of Units or improvements to be constructed thereon, and to erect on the Condominium Property signs and other promotional material to advertise Units for sale or lease.

5.9.8. DECLARANT ACTIVITIES. The Declarant, for itself, its affiliates and its and their respective successors and assigns: (i) reserves easements over the Condominium Property as the Declarant in its sole discretion deems necessary to commence, complete, operate, maintain, repair and replace the Buildings; and (ii) reserves the right to temporarily prohibit access to any portion of the Common Elements or uncompleted Units to any of the Occupants, and to utilize portions of the Common Elements in connection with the construction and development of the Buildings. THERE MAY BE CONSTRUCTION RELATED NOISES AND OTHER INTERRUPTIONS DURING THE CONSTRUCTION OR RENOVATION OF THE BUILDINGS, THE FACILITIES AND IMPROVEMENTS OF THE ASSOCIATION AND ANY OTHER BUILDINGS AND IMPROVEMENTS THAT MAY BE DEVELOPED FROM TIME TO TIME WITHIN THE CONDOMINIUM. NO UNIT OWNER OR SUCH UNIT OWNER'S GUESTS OR INVITEES SHALL IN ANY MANNER INTERFERE WITH ANY SUCH CONSTRUCTION. BY THE ACCEPTANCE OF THEIR DEED OR OTHER CONVEYANCE OR MORTGAGE, LEASEHOLD, LICENSE OR OTHER INTEREST, AND BY USING ANY PORTION OF THE CONDOMINIUM PROPERTY, EACH SUCH OWNER, OCCUPANT AND USER AUTOMATICALLY ACKNOWLEDGES, STIPULATES AND AGREES (I) THAT NONE OF THE AFORESAID ACTIVITIES SHALL BE DEEMED

NUISANCES OR NOXIOUS OR OFFENSIVE ACTIVITIES, UNDER THIS DECLARATION OR AT LAW GENERALLY, (II) NOT TO ENTER UPON, OR ALLOW THEIR CHILDREN OR OTHER PERSONS UNDER THEIR CONTROL OR DIRECTION TO ENTER UPON (REGARDLESS OF WHETHER SUCH ENTRY IS A TRESPASS OR OTHERWISE) ANY PROPERTY WITHIN OR IN PROXIMITY TO AREA WHERE SUCH ACTIVITY IS BEING CONDUCTED (EVEN IF NOT BEING ACTIVELY CONDUCTED AT THE TIME OF ENTRY, SUCH AS AT NIGHT OR OTHERWISE DURING NON-WORKING HOURS), (III) THE DECLARANT AND THE OTHER AFORESAID RELATED PARTIES SHALL NOT BE LIABLE FOR ANY AND ALL LOSSES, DAMAGES (COMPENSATORY, CONSEQUENTIAL, PUNITIVE OR OTHERWISE) INJURIES OR DEATHS ARISING FROM OR RELATING TO THE AFORESAID ACTIVITIES, EXCEPT RESULTING DIRECTLY FROM THE DECLARANT'S GROSS NEGLIGENCE OR WILLFUL MISCONDUCT, AND (IV) ANY PURCHASE OR USE OF ANY UNIT HAS BEEN AND WILL BE MADE WITH FULL KNOWLEDGE OF THE FOREGOING.

5.9.9. CONDOMINIUM ASSOCIATION EASEMENTS. A perpetual, non-exclusive easement is hereby granted to the Association to enter onto the Condominium Property, for the purpose of performing such functions as are permitted or required to be performed by the Association in connection with its duties. Such easement shall permit access to the Units provided that, except in the case of emergencies, entry shall not be made without reasonable notice (one (1) day's notice or attempted notice shall be deemed reasonable, except that notice shall not be required if the Unit Owner is absent when the giving of notice is attempted).

5.9.10. WARRANTY. For as long as the Declarant remains liable under any warranty, whether statutory, express or implied, for any act or omission of the Declarant (its agents, contractors or designees) in the development, construction, sale and marketing of the Condominium, then the Declarant and its contractors, agents and designees shall have the right, in the Declarant's sole discretion and from time to time and without requiring the prior approval of the Association and/or any Unit Owner (provided, however, that absent an emergency situation, the Declarant shall provide reasonable advance notice), to enter the Condominium Property, including, without limitation, the Units, the Common Elements and the Limited Common Elements, for the purpose of inspecting, testing and surveying same to determine the need for repairs, improvements and/or replacements, and effecting same, so that the Declarant can fulfill any of its warranty obligations. Failure of the Association or any Unit Owner to grant such access may, at the election of the Declarant, result in the appropriate warranty being nullified and of no further force or effect. Nothing herein shall be deemed or construed as the Declarant making or offering any warranty, all of which are disclaimed (except to the extent same may not be) as set forth in Section 23.

5.9.11. EXTERIOR MAINTENANCE/WINDOW WASHING. An easement is hereby reserved on, through and across each Unit and all Limited Common Elements appurtenant thereto in order to afford access to the Association (and its contractors) to stage window washing equipment and to perform window washing and/or any other exterior maintenance and/or painting of the Buildings. However, this creates no obligation to do so.

5.9.12. **ADDITIONAL EASEMENTS.** The Association, through its Board of Directors, on the Association's behalf and on behalf of all Unit Owners (each of whom hereby appoints the Association as its attorney-in-fact for this purpose), shall have the right to grant such additional general ("blanket") and specific electric, gas, other utility, cable television, security systems, communications or service easements (and appropriate bills of sale for equipment, conduits, pipes, lines and similar installations pertaining thereto), or modify or relocate any such existing easements or drainage facilities in any portion of the Condominium Property, and to grant access easements or relocate any existing access easements in any portion of the Condominium Property, as the Board shall deem necessary or desirable for the proper operation and maintenance of the improvements, or any portion thereof, for the general health and welfare of the Unit Owners or for the purpose of carrying out any provisions of this Declaration; provided that such easements or the relocation of existing easements will not prevent or unreasonably interfere with the reasonable use of the Units for dwelling purposes.

5.9.13. **BENEFICIARIES.** The easements reserved and granted in this Section 5 shall be covenants running with the land for the benefit and in favor of the Unit Owners, the Declarant and the Association, as applicable, and their successors, assigns, agents, employees, guests, licensees and invitees for all proper purposes, and providers of utility services, cable television, communications, security systems and other services and drainage, as may be required or helpful to serve the Units, Common Elements and Limited Common Elements subject to the provisions of this Declaration of Condominium and rules and regulations of the Condominium. However, nothing in this Section 5.9 shall constitute any party a beneficiary of any easement in Limited Common Elements for any purpose reserved to the use of a particular Unit or Units, except for the Unit Owner or Unit Owners of that Unit or those Units and the invitees of the Unit Owner or Unit Owners.

5.10. **LIMITED COMMON ELEMENTS.** Each Unit may have, to the extent applicable and subject to the provisions of this Declaration, as Limited Common Elements appurtenant thereto: (i) the exterior entry area contiguous to the Unit, (ii) the patio and/or balcony contiguous to the Unit; (iii) the paved driveway leading exclusively to the garage(s) of the Unit; (iv) and those portions of driveways located adjacent to a Unit's garage and between such garage and the street or private drive or roadway; (v) the curbed islands between the driveways to each Unit; and (vi) any other areas designated as Limited Common Elements on the Condominium Plot Plan, all as graphically depicted on the Condominium Plot Plan.

5.10.1. **EXCLUSIVE USE AND TRANSFER OF LIMITED COMMON ELEMENTS.** If, after all of the Units have been sold by the Declarant, the exclusive use of any Limited Common Element applicable to a Unit was not, for any reason, assigned to the use of a specific Unit(s) by the Declarant, the Association may do so. The right of exclusive use of each Limited Common Element passes with the Unit to which it is assigned, whether or not separately described, and cannot be separated from it.

5.11. **USE OF LIMITED COMMON ELEMENTS.** The use and enjoyment of the Limited Common Elements shall be in accordance with the terms and provisions of this Declaration, including, without limitation, the restrictions provided in this Section 5 and Section 15 of this Declaration, and the other Condominium Documents.

6. COMMON ELEMENTS AND COMMON SURPLUS; VOTING RIGHTS.

6.1. SHARE OF. Each Unit has appurtenant to it an undivided percentage interest in the Common Elements and Common Surplus. The undivided percentage interest in the Common Elements and Common Surplus appurtenant to each Unit, and the percentage share of the Common Expenses is as set forth on Exhibit "E" attached to and made a part of this Declaration (the "Allocated Interests").

6.2. USE. Each Unit Owner and the Association will be entitled to use the Common Elements in accordance with the purposes for which the elements are intended; however, no such use may hinder or encroach upon the lawful rights of other Unit Owners.

6.3. VOTING. Each Unit shall have one full indivisible vote in all matters.

7. MAINTENANCE.

The responsibility for protection, maintenance, repair and replacement of the Condominium Property, and restrictions on its alteration and improvement shall be as follows:

7.1. UNITS. Each Unit Owner is responsible, at such Unit Owner's own expense, for all maintenance, repairs, and replacements of the Unit Owner's Unit, and the fixtures, equipment and appliances comprising a part thereof, located therein or exclusively serving the same (but not otherwise including Limited Common Elements except where expressly so indicated in this Section 7). Each Unit Owner is responsible for all decorating within such Unit Owner's Unit, including painting, wallpapering, paneling, floor covering, draperies, window shades, curtains, lamps and other light fixtures, and other furnishings and interior decorating. Any emergency maintenance, repairs and/or replacements for which Unit Owners are responsible and obligated to perform, which, if not performed or omitted, would affect other Units or Common Elements, shall be performed promptly as the need arises, and if Unit Owner(s) fails to promptly perform these, the Association shall have the right to perform these obligations. Notwithstanding the obligation of Unit Owners for maintenance, repair or replacement of and in Units, the proceeds of all insurance awards or payments under insurance carried by the Association for loss of, or damage to Units shall be applied against repairs and replacements to the extent that such award or payments exceed the deductible provisions of such insurance.

7.2. COMMON ELEMENTS AND ASSOCIATION PROPERTY. The Association is responsible for the protection, maintenance, repair and replacement of all Common Elements and Association Property (other than those Limited Common Elements that are required in this Section 7 to be maintained by the Unit Owner). The costs of maintaining the Common Elements and the Association Property shall be Common Expenses. All incidental damage caused to a Unit or Limited Common Elements by work performed or ordered to be performed by the Association shall be promptly repaired by and at the expense of the Association, which shall restore the property as nearly as practical to its condition before the damage, and the cost of such repair shall be a Common Expense, except the Association shall not be responsible for the damage to any alteration or addition to the Common Elements made by a Unit Owner or his predecessor in title or for damage to paint, wallpaper, paneling, flooring or carpet which, of necessity, must be cut or removed to gain access to work areas located behind them.

7.3. LIMITED COMMON ELEMENTS. The Association is responsible for the protection, maintenance, repair and replacement of all Limited Common Elements, except as provided in this Section 7.3 as follows:

7.3.1. PATIOS AND BALCONIES. Where a Limited Common Element consists of a patio or balcony, the Unit Owner who has the right of exclusive use of the area shall be responsible, at such Unit Owner's sole cost and expense, for: (i) the day-to-day cleaning and care of the walls, floor and ceiling bounding said area, if any; (ii) the maintenance, repair and replacement of the flooring of the patios and balconies (provided that the Association reserves the right, but not the obligation, to maintain (other than the day to day cleaning), repair and replace the flooring of the patios and balconies and charge such costs as Common Expenses); (iii) the maintenance, repair and replacement of the screens, if any, enclosing and covering the patios and balconies (provided that the Association reserves the right, but not the obligation, to maintain (other than the day to day cleaning), repair and replace the screens covering the patios and balconies and charge such costs as Common Expenses); (iv) all fixed glass and sliding glass doors in portions of the entrance way to said balconies, if any; and (v) the wiring, electrical outlet(s) and fixture(s) thereon, if any, and the replacement of light bulbs.

7.4. SERVICE AND MAINTENANCE CONTRACTS. If there shall become available to the Association: (i) a program of contract maintenance for items which are located within the Units and otherwise the responsibility of the Unit Owner, such as water heaters and/or air conditioning compressors and/or air handlers and related equipment serving individual Units; or (ii) certain contract services to be delivered within the Units for items otherwise the responsibility of the Unit Owner, such as pest control or cable television, then, the Board may, but shall not be obligated to, enter in any such contracts which the Board determines are to the benefit of the Unit Owners generally. The expenses of such contractual undertakings to the Association shall be a Common Expense. All maintenance, repairs and replacements not covered by the contracts shall remain the responsibility of the Unit Owner. Since such expenses shall constitute Common Expenses, an election by a Unit Owner not to take advantage of the services or maintenance provided by such contracts, shall not excuse the Unit Owner from paying his share of the cost.

8. ALTERATIONS, ADDITIONS AND IMPROVEMENTS.

8.1. ALTERATIONS, ADDITIONS. Except for changes made by a Unit Owner with Association approval as provided in this Section 8, whenever in the judgment of the Board of Directors, the Common Elements, the Association Property, or any part of either, shall require capital additions, alterations or improvements (as distinguished from repairs and replacements) costing in excess of three percent (3%) of the then applicable budget of the Association in the aggregate in any calendar year, the Association may proceed with such additions, alterations or improvements only if the making of such additions, alterations or improvements shall have been approved by a majority of the Voting Interests represented at a meeting at which a quorum is attained. Any such additions, alterations or improvements to such Common Elements, the Association Property, or any part of either, costing in the aggregate of up to three percent (3%) of the then applicable budget of the Association or less may be made by the Association without approval of the Unit Owners. Subject to compliance with the provisions of Section 718.112(2)(e) of the Condominium Act, the cost and expense of any such additions, alterations or

improvements to such Common Elements or Association Property shall constitute a part of the Common Expenses and shall be assessed to the Unit Owners as Common Expenses. For purposes of this section, "aggregate in any calendar year" shall include the total debt incurred in that year, if such debt is incurred to perform the above-stated purposes, regardless of whether the repayment of any part of that debt is required to be made beyond that year. The Board of Directors may lease or grant easements or licenses for the use of Common Elements or Condominium Property if such use will benefit the members of the Association and may charge for such use.

8.2. IMPROVEMENTS, ADDITIONS OR ALTERATIONS BY UNIT OWNERS. No Unit Owner shall make any addition, alteration or improvement in or to the Common Elements or the Association Property, nor any structural addition, alteration or improvement in or to the Unit Owner's Unit or any Limited Common Element, nor any addition, alteration or improvement to Unit or any Limited Common Element which is visible from any other Unit or the Common Elements, without, in each instance, the prior written consent of the Board of Directors. The Board shall have the obligation to answer, in writing, any written request by a Unit Owner for approval of such an addition, alteration or improvement within thirty (30) days after receipt in writing of such request and all additional information requested by the Board, and the failure to do so within the stipulated time shall constitute the Board's consent. The Board has the authority to approve, disapprove, or require, in its sole discretion, modifications to the proposed work. The Board may condition the approval in any manner, including, without limitation, retaining approval rights of the contractor, engineer and/or other professionals as a prerequisite to perform the work. The Board's decision will be determinative of the matter. Unit Owners shall obtain all necessary approvals and permits from applicable government entities, prior to making any alterations, or adding or removing such Common Elements or other improvements. All expenses of any kind (including, without limitation, attorneys' fees and costs of the Association) in connection with such work shall be borne by the Unit Owner in question, including with respect to any subsequent maintenance or restoration. No Unit Owner will do any work or cause any work to be performed that would jeopardize the safety or soundness of the Building, increase insurance requirements or premiums or impair any easements. Proposed additions, alterations and improvements by Unit Owners shall be made in compliance with all laws, rules, ordinances and regulations of all governmental authorities having jurisdiction, and with any conditions imposed by the Association with respect to design, structural integrity, aesthetic appeal, construction details, lien protection or otherwise. Once approved by the Board of Directors, such approval may not be revoked. The Association's rights of review and approval of plans and other submissions under this Declaration are intended solely for the benefit of the Association. Neither the Declarant, the Association nor any of its officers, directors, employees, agents, contractors, consultants or attorneys shall be liable to any Unit Owner or any other person by reason of mistake in judgment, failure to point out or correct deficiencies in any plans or other submissions, negligence, or any other misfeasance, malfeasance or non-feasance arising out of or in connection with the approval or disapproval of any plans or submissions. Anyone submitting plans, by the submission of same, and any Unit Owner, by acquiring title to same, agrees not to seek damages from the Declarant and/or the Association arising out of the Association's review of any plans hereunder. Without limiting the generality of the foregoing, the Association shall not be responsible for reviewing, nor shall its review of any plans be deemed approval of, any plans from the standpoint of structural safety, soundness, workmanship, materials, usefulness, conformity with building or other codes or industry standards, or

compliance with governmental requirements. Further, each Unit Owner (including the Unit Owner's successors and assigns) agrees to indemnify and hold the Declarant and the Association harmless from and against any and all costs, claims (whether rightfully or wrongfully asserted), damages, expenses or liabilities whatsoever (including, without limitation, reasonable attorneys' fees and court costs at all trial and appellate levels), arising out of any review of plans by the Association hereunder. A Unit Owner making or causing to be made any approved additions, alterations or improvements agrees, and shall be deemed to have agreed, for such Owner, and his heirs, personal representatives, successors and assigns, as appropriate, to: (i) be solely financially responsible for maintenance, repair, cleaning, replacement and insurance of the modifications, installations and additions from and after the date of installation or construction thereof as may be required by the Association, the costs of repairing any damage to the Common Elements or other Units resulting from the existence of such modifications, installations or additions and the costs of removing, replacing and reinstalling such modifications if their removal by the Association becomes necessary in order to maintain, repair, replace, or protect other parts of the Condominium Property for which the Association is responsible; and (ii) hold the Association, the Declarant and all other Unit Owners harmless from and to indemnify them for any liability or damage to the Condominium and/or Association Property and expenses arising therefrom, and shall be solely responsible for the maintenance, repair and insurance thereof. If any Unit Owner fails or neglects to maintain, repair, clean and replace as required by this Section 8.2, and such failure or neglect continues for fifteen (15) days after such Unit Owner's receipt of written notice of such neglect or failure from the Association, then (subject to the provisions of the Condominium Act), the Association may, but shall not be obligated to, take appropriate steps to perform, or cause to be performed, the maintenance, repair, cleaning and replacement in the manner as required by this Section 8.2. The defaulting Unit Owner shall, upon demand, reimburse the Association for all of costs and expenses incurred by the Association in the exercise of its rights pursuant to this Section 8.2. Any amounts not paid within ten (10) days from the Unit Owner's receipt of demand from the Association shall bear interest at the lesser of eighteen percent (18%) per annum or the highest rate permitted by law from the date due until paid in full.

8.3. OWNER'S CONTRACTORS; DAMAGES. Whenever a Unit Owner contracts for maintenance, repair, replacement, alteration, addition or improvement of any portion of the Unit or Common Elements, whether with or without Association approval, such Unit Owner shall be deemed to have warranted to the Association and its members that such Unit Owner's contractor(s) are properly licensed and fully insured, and that such Unit Owner will be financially responsible for any resulting damage to persons or property.

8.4. IMPROVEMENTS, ADDITIONS OR ALTERATIONS BY DECLARANT. Anything to the contrary notwithstanding, the foregoing restrictions of this Section 8 shall not apply to Declarant-owned Units. Subject to the provisions of this Section 8.4, the Declarant shall have the additional right, without the consent or approval of the Board of Directors or other Unit Owners, to make alterations, additions or improvements, structural and non-structural, interior and exterior, ordinary and extraordinary, in, to and upon any Unit owned by it and Limited Common Elements appurtenant thereto (including, without limitation, the removal of walls, floors, ceilings and other structural portions of the improvements), and to expand, alter or add to all or any part of the recreational facilities. Any amendment to this Declaration required by a change made by the Declarant pursuant to this Section 8.4 shall be adopted in accordance with

Section 18 of this Declaration. Without limiting the generality of the provisions of this Section but subject to the provisions of this Section, the Declarant shall have the right, without the vote or consent of the Association or Unit Owners, to (a) make alterations, additions or improvements in, to and upon Units owned by the Declarant, whether structural or non-structural, interior or exterior, ordinary or extraordinary; (b) change the layout or number of rooms in any Declarant-owned Units; (c) change the size of Declarant-owned Units by combining separate Declarant-owned Units into a single apartment (although being kept as two separate legal Units), or otherwise; and (d) reapportion among the Declarant-owned Units affected by such change in size pursuant to the preceding clause, their appurtenant interests in the Common Elements and share of the Common Surplus and Common Expenses; provided, however, that the percentage interest in the respective Common Elements and share of the respective Common Surplus and respective Common Expenses of any Units (other than the affected Declarant-owned Units) shall not be changed by reason thereof unless the Owners of such Units shall consent thereto and, provided further, that Declarant shall comply with all laws, ordinances and regulations of all governmental authorities having jurisdiction in so doing. In making the above alterations, additions and improvements, the Declarant may relocate and alter Common Elements adjacent to or near such Units, incorporate portions of the Common Elements into adjacent Units and incorporate Units into adjacent Common Elements, provided that such relocation and alteration does not materially adversely affect the market value or ordinary use of Units owned by Unit Owners other than the Declarant. Any amendments to this Declaration required by changes of the Declarant made pursuant to this Section 8.4 may be effected by the Declarant alone pursuant to Section 18.2, without the vote or consent of the Association or Unit Owners (or their mortgagees) required, except to the extent that the vote or consent of the Association or the Unit Owners (or their respective Mortgagees) is required in order to comply with the provisions of Section 718.110(4) of the Condominium Act. Without limiting the generality of Section 18 hereof, the provisions of this Section may not be added to, amended or deleted without the prior written consent of the Declarant. Notwithstanding any of the foregoing provisions of this Section 8.4 to the contrary, the Declarant may not change the configuration or size of any condominium unit in any material fashion, materially alter or modify the appurtenances to the Unit, or change the proportion or percentage by which the owner of the Unit shares common expenses and owns the common surplus, unless the Declarant complies with the provisions of Section 718.110(4) of the Condominium Act.

9. ADMINISTRATION, POWERS AND DUTIES AND FISCAL MANAGEMENT.

9.1. **POWERS AND DUTIES.** The Association shall be the entity responsible for the operation of the Condominium and the Association Property. The powers and duties of the Association shall include those set forth in the Articles and By-Laws. In addition, the Association shall have all the powers and duties set forth in the Condominium Act and under applicable law, as well as all powers and duties granted to or imposed upon it by this Declaration, including, without limitation:

9.1.1. the irrevocable right to have access to each Unit from time to time during reasonable hours as may be necessary for pest control purposes and for the maintenance, repair or replacement of any Common Elements or any portion of a Unit, if any, to be maintained by the Association, or at any time and by force, if necessary, to prevent damage to the Common Elements, the Association Property or to a Unit or Units;

9.1.2. the power to make and collect Assessments and other charges against Unit Owners and to lease, maintain, repair and replace the Common Elements and Association Property;

9.1.3. the duty to maintain accounting records according to good accounting practices, which shall be open to inspection by Unit Owners or their authorized representatives at reasonable times upon prior request;

9.1.4. the power to contract for the management and maintenance of the Condominium Property and to authorize a management agent (who may be an affiliate of the Declarant) to assist the Association in carrying out its powers and duties by performing such functions as the submission of proposals, collection of Assessments, preparation of records, enforcement of rules and maintenance, repair and replacement of Common Elements with such funds as shall be made available by the Association for such purposes. The Association and its officers shall, however, retain at all times the powers and duties granted in the Condominium Documents and the Condominium Act, including, but not limited to, the making of Assessments, promulgation of rules and execution of contracts on behalf of the Association;

9.1.5. the power to borrow money, execute promissory notes and other evidences of indebtedness and to give as security therefor mortgages and security interests in property owned by the Association, if any, provided that such actions are approved by a majority of the entire membership of the Board of Directors and a majority of the Units represented at a meeting at which a quorum has been attained, or by such greater percentage of the Board or Unit Owners as may be specified in the By-Laws with respect to certain borrowing;

9.1.6. the power to adopt and amend rules and regulations concerning the details of the operation and use of the Condominium, the Condominium Property and the Association Property;

9.1.7. the power to acquire, convey, lease and encumber real and personal property. Personal property shall be acquired, conveyed, leased or encumbered upon a majority vote of the Board of Directors, subject to Section 8.1. Real property (including, without limitation, any of the Units) shall be acquired, conveyed, leased or encumbered by the Association upon a majority vote of the Board of Directors alone; provided that the requirements of Section 8.1 pertaining to the Unit Owners' approval of costs in excess of the threshold amount stated therein (including the proviso regarding the debt incurred) shall also apply to the acquisition of real property; provided, further, however, that the acquisition of any Unit as a result of a foreclosure of the lien for Assessments (or by deed in lieu of foreclosure) shall be made upon the majority vote of the Board of Directors, regardless of the price for same, and the Association, through the Board of Directors, has the power to hold, lease, mortgage or convey the acquired Unit(s) without requiring the consent of Unit Owners. The expenses of ownership (including the expense of making and carrying any mortgage related to such ownership), rental, membership fees, taxes, Assessments, operation, replacements and other expenses and undertakings in connection therewith shall be General Common Expenses;

9.1.8. the power to execute all documents or consents, on behalf of all Unit Owners (and their mortgagees), required by all governmental and/or quasi governmental

agencies in connection with land use and development matters (including, without limitation, plats, waivers of plat, unities of title, covenants in lieu thereof, etc.), and in that regard, each Unit Owner, by acceptance of the deed to such Unit Owner's Unit, and each mortgagee of a Unit Owner by acceptance of a lien on said Unit, appoints and designates the President or Vice President of the Association, as such Unit Owner's agent and attorney-in-fact to execute any and all such documents or consents; and

9.1.9. all of the powers which a corporation not for profit in the State of Florida may exercise pursuant to this Declaration, the Articles of Incorporation, the By-Laws, Chapters 607 and 617, Florida Statutes (2005) and any amendments or replacements thereof and the Condominium Act, as amended, in all cases except as expressly limited or restricted in the Condominium Act. In the event of conflict among the powers and duties of the Association or the terms and provisions of this Declaration, exhibits attached to this Declaration or otherwise; this Declaration shall take precedence over the Articles of Incorporation, By-Laws and the Rules and Regulations; the Articles of Incorporation shall take precedence over the By-Laws and the Rules and Regulations; and the By-Laws shall take precedence over the Rules and Regulations, all as amended from time to time. Notwithstanding anything in this Declaration, the Association shall at all times be the entity having ultimate control over the Condominium, consistent with the Condominium Act.

9.2. LIMITATION UPON LIABILITY OF ASSOCIATION. Notwithstanding the duty of the Association to maintain and repair parts of the Condominium Property, the Association shall not be liable to Unit Owners for injury or damage, other than for the cost of maintenance and repair, caused by any latent condition of the Condominium Property. Further, the Association shall not be liable for any such injury or damage caused by defects in design or workmanship or any other reason connected with any additions, alterations or improvements or other activities done by or on behalf of any Unit Owners regardless of whether or not same shall have been approved by the Association. The Association also shall not be liable to any Unit Owner or lessee or to any other person or entity for any property damage, personal injury, death or other liability on the grounds that the Association did not obtain or maintain insurance (or carried insurance with any particular deductible amount) for any particular matter where: (i) such insurance is not required hereby; or (ii) the Association could not obtain such insurance at reasonable costs or upon reasonable terms.

9.3. RESTRAINT UPON ASSIGNMENT OF SHARES IN ASSETS. The share of a Unit Owner in the funds and assets of the Association cannot be assigned, hypothecated or transferred in any manner except as an appurtenance to his Unit.

9.4. APPROVAL OR DISAPPROVAL OF MATTERS. Whenever the decision of a Unit Owner is required upon any matter, whether or not the subject of an Association meeting, that decision shall be expressed by the same person who would cast the vote for that Unit if at an Association meeting, unless the joinder of all record Owners of the Unit is specifically required by this Declaration or the By-Laws.

9.5. ACTS OF THE ASSOCIATION. Unless the approval or action of Unit Owners, and/or a certain specific percentage of the Board of Directors of the Association, is specifically required in the Condominium Act, other applicable law or the Condominium Documents, all

approvals or actions required or permitted to be given or taken by the Association shall be given or taken by the Board of Directors, without the consent of Unit Owners, and the Board of Directors may so approve and act through the proper officers of the Association without a specific resolution. When an approval or action of the Association is permitted to be given or taken hereunder or thereunder, such action or approval may be conditioned in any manner the Association deems appropriate or the Association may refuse to take or give such action or approval without the necessity of establishing the reasonableness of such conditions or refusal.

10. DETERMINATION OF COMMON EXPENSES AND FIXING OF ASSESSMENTS THEREFOR. The Board of Directors shall from time to time, and at least annually, prepare a budget for the Condominium and the Association, determine the amount of Assessments payable by the Unit Owners to meet the Common Expenses of the Condominium and allocate and assess such expenses among the Unit Owners in accordance with the provisions of the Condominium Documents. The Board of Directors shall advise all Unit Owners promptly in writing of the amount of the Assessments payable by each of them as determined by the Board of Directors as set forth in the Condominium Documents and shall furnish copies of the budget, on which such Assessments are based, to all Unit Owners and (if requested in writing) to their respective mortgagees. The Common Expenses shall include the expenses of and reserves for (if required by, and not waived in accordance with, applicable law) the operation, maintenance, repair and replacement of the Common Elements and Association Property, costs of carrying out the powers and duties of the Association and any other expenses designated as Common Expenses by the Condominium Act, this Declaration, the Articles, By-Laws, or Rules and Regulations or by the Association. Incidental income to the Association, if any, may be used to pay regular or extraordinary Association expenses and liabilities, to fund reserve accounts, or otherwise as the Board shall determine from time to time, and need not be restricted or accumulated. Any Budget adopted shall be subject to change to cover actual expenses at any time. Any such change shall be adopted consistent with the provisions of the Condominium Documents.

11. COLLECTION OF ASSESSMENTS.

11.1. **LIABILITY FOR ASSESSMENTS.** A Unit Owner, regardless of how title is acquired, including by purchase at a foreclosure sale or by deed in lieu of foreclosure, shall be liable for all Assessments coming due while he, she or it is the Unit Owner. Additionally, a Unit Owner shall be jointly and severally liable with the previous Unit Owner for all unpaid Assessments that came due up to the time of the conveyance, without prejudice to any right the Unit Owner may have to recover from the previous Unit Owner the amounts paid by the grantee Unit Owner. Liability for Assessments may not be avoided by waiver of the use or enjoyment of any Common Elements or by the abandonment of the Unit for which the Assessments are made or otherwise.

Notwithstanding anything contained in this Declaration of Condominium, the Articles of Incorporation or the By-Laws to the contrary, at the time of the recording of this Declaration, the Declarant has the option of either activating the below guarantee of Assessments by checking the box contained on the signature page of this Declaration, or leaving such box empty, in which event the Declarant will pay Assessments on Declarant-owned Units. If the box contained on the signature page of this Declaration is checked, then from the recording of this Declaration until

the earlier of six (6) months from the recording of the Declaration of Condominium, or the date on which the Declarant shall first give written notice to Unit Owners of the first meeting of Unit Owners at which they will elect a majority of the Board of Directors, the Declarant is not obligated to pay assessments on Units which it owns, but the Declarant guarantees that until the earlier of said dates Assessments will not increase over the stated dollar amounts specified in the Prospectus. The Declarant shall have the right to extend the period of exemption from assessments for Common Expenses against Units owned by it by extending the period of the guaranty as set forth in the Prospectus and provided that it shall do so in compliance with any applicable requirements of the Condominium Act and Rule 61B-22.004 of the Florida Administrative Code Rules. The Declarant, in its sole discretion, has the right and option to extend the period of exemption from Assessments against Declarant-owned Units for consecutive additional one (1) month periods of time until such time as the Declarant turns over operation and control of the Association to the Unit Owners other than the Declarant, provided that it shall do so in compliance with any applicable requirements of Section 718.116(9) of the Condominium Act and Rule 61B-22.004(2)(c) of the Florida Administrative Code Rules. Notwithstanding the foregoing, and as provided in Section 718.116(9)(a)(2) of the Condominium Act, in the event of an Extraordinary Financial Event (as subsequently defined), the costs necessary to effect restoration shall be assessed against all Unit Owners owning Units on the date of such natural disaster or act of God, and their successors and assigns, including the Declarant (with respect to Units owned by the Declarant). As used in this subsection, an "Extraordinary Financial Event" shall mean a casualty loss affecting the Condominium resulting from a natural disaster or act of God, which is not covered by insurance proceeds from the insurance maintained by the Association as required by Section 718.111(11) (a) of the Condominium Act.

11.2. SPECIAL AND CAPITAL IMPROVEMENT ASSESSMENTS. In addition to Assessments levied by the Association to meet the Common Expenses of the Condominium and the Association, the Board of Directors may levy Special Assessments and Capital Improvement Assessments. Such Special Assessments and Capital Improvement Assessments shall be payable in lump sums or installments, in the discretion of the Board; provided that, if such Special Assessments or Capital Improvement Assessments, in the aggregate in any year, exceed \$150,000.00 or cause the total Assessments levied to exceed 115% of Assessments for the preceding calendar year, the Board of Directors must obtain approval of a majority of the Unit Owners Units represented at a meeting at which a quorum is attained.

11.3. DEFAULT IN PAYMENT OF ASSESSMENTS FOR COMMON EXPENSES. Assessments and installments thereof not paid within ten (10) days from the date when they are due shall bear interest at the lessor of eighteen percent (18%) per annum or the highest rate permitted by law from the date due until paid and shall be subject to an administrative late fee in an amount not to exceed the greater of \$25.00 or five percent (5%) of each delinquent installment. The Association has a lien on each Condominium Parcel to secure the payment of Assessments. Except as set forth below, the lien is effective from, and shall relate back to, the date of the recording of this Declaration. However, as to first mortgages of record, the lien is effective from and after recording of a claim of lien. The lien shall be evidenced by the recording of a claim of lien in the Public Records of the County. To be valid, the claim of lien shall state the description of the Condominium Parcel, the name of the record Unit Owner, the name and address of the Association, the amount due and the due dates, and the claim of lien shall be executed and acknowledged by an officer or authorized officer of the Association. The

claim of lien shall not be released until all sums secured by it (or such other amount as to which the Association shall agree by way of settlement) have been fully paid or until it is barred by law. No such lien shall be effective longer than one (1) year after the claim of lien has been recorded unless, within that one (1) year period, an action to enforce the lien is commenced. The one (1) year period shall automatically be extended for any length of time during which the Association is prevented from filing a foreclosure action by an automatic stay resulting from a bankruptcy petition filed by the Unit Owner or any other person claiming an interest in the Unit. The claim of lien shall secure (whether or not stated therein) all unpaid Assessments, which are due and which may accrue subsequent to the recording of the claim of lien and prior to the entry of a certificate of title, as well as interest and all reasonable costs and attorneys' fees of any kind incurred by the Association incident to the collection process. Upon payment in full, the person making the payment is entitled to a satisfaction of the lien in recordable form. The Association may bring an action in its name to foreclose a lien for unpaid Assessments in the manner a mortgage of real property is foreclosed and may also bring an action at law to recover a money judgment for the unpaid Assessments without waiving any claim of lien. The Association is entitled to recover its reasonable attorneys' fees and costs incurred either in a lien foreclosure action or an action to recover a money judgment for unpaid Assessments. As an additional right and remedy of the Association, upon default in the payment of Assessments and after thirty (30) days' prior written notice to the applicable Unit Owner and the recording of a claim of lien, the Association may declare the Assessment installments due for the remainder of the budget year in which the claim of lien was filed to be accelerated and immediately due and payable. If the amount of such installments changes during the remainder of such budget year, the Unit Owner or the Association, as appropriate, shall be obligated to pay or reimburse to the other the amount of increase or decrease within ten (10) days of same taking effect.

11.4. NOTICE OF INTENTION TO FORECLOSE LIEN. No foreclosure judgment may be entered until at least thirty (30) days after the Association gives written notice to the Unit Owner of its intention to foreclose its lien to collect the unpaid Assessments. If this notice is not given at least thirty (30) days before the foreclosure action is filed, and if the unpaid Assessments, including those coming due after the claim of lien is recorded, are paid before the entry of a final judgment of foreclosure, the Association shall not recover attorneys' fees or costs. The notice must be given by delivery of a copy of it to the Unit Owner or by certified or registered mail, return receipt requested, addressed to the Unit Owner at the Unit Owner's last known address, and upon such mailing, the notice shall be deemed to have been given. If after diligent search and inquiry the Association cannot find the Unit Owner or a mailing address at which the Unit Owner will receive the notice, the court may proceed with the foreclosure action and may award attorneys' fees and costs as permitted by law. The notice requirements of this subsection shall be deemed satisfied if the Unit Owner records a Notice of Contest of Lien as provided in the Condominium Act.

11.5. APPOINTMENT OF RECEIVER TO COLLECT RENTAL. If the Unit Owner remains in possession of the Unit after a foreclosure judgment has been entered, the court in its discretion may require the Unit Owner to pay a reasonable rental for the Unit. If the Unit is rented or leased during the pendency of the foreclosure action, the Association shall be entitled to the appointment of a receiver to collect the rent. The expenses of such receiver shall be paid by the party, which does not prevail in the foreclosure action.

11.6. **FIRST MORTGAGEE.** The liability of a First Mortgagee holding a first priority mortgage lien on a Unit, or its successor or assignees, which acquires title to a Unit by foreclosure or by deed in lieu of foreclosure, for the unpaid Assessments (or installments thereof) that became due prior to the First Mortgagee's acquisition of title is limited to the lesser of: (a) the Unit's unpaid Common Expenses and regular periodic Assessments which accrued or came due during the six (6) months immediately preceding the acquisition of title and for which payment in full has not been received by the Association; or (b) one percent (1%) of the original mortgage debt. As to a Unit acquired by foreclosure, the limitations set forth in clauses (a) and (b) above shall not apply unless the First Mortgagee joined the Association as a defendant in the foreclosure action. Joinder of the Association, however, is not required if, on the date the complaint is filed, the Association was dissolved or did not maintain an office or agent for service of process at a location that was known to or reasonably discoverable by the mortgagee. A First Mortgagee acquiring title to a Unit as a result of foreclosure or deed in lieu thereof may not, during the period of its ownership of such Unit, whether or not such Unit is unoccupied, be excused from the payment of some or all of the Common Expenses coming due during the period of such ownership.

11.7. **INSTALLMENTS.** Regular Assessments shall be collected monthly or quarterly, in advance, at the option of the Association. Initially, Assessments will be collected quarterly.

11.8. **APPLICATION OF PAYMENTS.** Any payments received by the Association from a delinquent Unit Owner shall be applied first to any interest accrued on the delinquent installment(s), then to any administrative late fees, then to any costs and reasonable attorneys' fees incurred in collection and then to the delinquent and any accelerated Assessments. The immediately preceding sentence shall be applicable notwithstanding any restrictive endorsement, designation or instruction placed on or accompanying a payment.

11.9. **ESTOPPEL CERTIFICATE.** Within fifteen (15) days after receiving a written request therefor from a purchaser, the Unit Owner or mortgagee of a Unit, the Association shall provide a certificate, signed by an officer or agent of the Association, stating all Assessments and other monies owed to the Association by the Unit Owner with respect to the Unit Owner's Unit. Any person other than the Unit Owner who relies upon such certificate shall be protected thereby.

12. INSURANCE. In order to adequately protect the Unit Owners, the Association, and all parts of the Condominium Property and Association Property that are required to be insured by the Association, insurance shall be carried and kept in force at all times in accordance with the following provisions:

12.1. **AUTHORITY TO OBTAIN.** The Association shall use its best efforts to obtain and maintain adequate insurance to protect the Association, the Association Property, the Common Elements and the Condominium Property required to be insured by the Association pursuant to the Condominium Act. All insurance purchased by the Association shall identify the name of the insured as the Association, singularly and as agent for the Unit Owners covered by the policy.

12.2. BASIC INSURANCE. The Association will procure insurance covering the Building and improvements as well as all insurable Association Property, in an amount determined annually by the Board of Directors. Such insurance shall afford the following protection:

12.2.1. CASUALTY. All portions of the Condominium Property located outside of the boundaries of the Units and such portions of the Condominium Property located within the boundaries of the Units that are required by the Condominium Act to be insured under the Association's policies from time to time (collectively the "Insured Property"), shall be insured in such adequate amounts and coverages as are determined by the Board of Directors from time to time. Notwithstanding the foregoing, the Insured Property shall not include, and shall specifically exclude, floor, wall and ceiling coverings, electrical fixtures, appliances, air conditioning or heating equipment, water heaters, water filters, built-in cabinets and countertops, and window treatments, including curtains, drapes, blinds, hardware and similar window treatment components, or replacements of any of the foregoing which are located within the boundaries of a Unit and serve only one Unit and all air conditioning compressors that service only an individual Unit, whether or not located within the Unit boundaries. Such policies may contain reasonable deductible provisions as determined by the Board of Directors of the Association. Such coverage shall afford protection against loss or damage by fire and other hazards covered by a standard extended coverage endorsement, and such other risks as from time to time are customarily covered with respect to buildings and improvements similar to the Insured Property in construction, location and use, including, but not limited to, vandalism and malicious mischief.

Every casualty insurance policy obtained by the Association, if required by FNMA/FHLMC, shall have the following endorsements: (a) agreed amount and inflation guard and (b) steam boiler coverage (providing at least \$50,000.00 coverage for each accident at each location), if applicable.

12.2.2. FLOOD. The policy shall include replacement cost for the Building and insurable improvements, as available.

12.2.3. LIABILITY. Comprehensive general public liability and automobile liability insurance covering loss or damage resulting from accidents or occurrences on or about or in connection with the Insured Property or adjoining driveways and walkways, or any work, matters or things related to the Insured Property, with such coverage as shall be required by the Board of Directors of the Association, but with combined single limit liability of not less than \$1,000,000.00 for each accident or occurrence, \$100,000.00 per person and \$50,000.00 property damage, and with a cross liability endorsement to cover liabilities of the Unit Owners as a group to any Unit Owner, and vice versa. The Association may also obtain and maintain liability insurance for its directors and officers and for the benefit of the Association's employees.

12.2.4. WORKERS' COMPENSATION. The Association shall maintain worker's compensation insurance to meet the requirements of law.

12.2.5. FIDELITY BONDING. The Association shall obtain and maintain blanket fidelity bonds for each person who controls or disburses funds of the Association and the

President, Vice President(s), Secretary and Treasurer of the Association in an amount not less than \$50,000.00 for each such person, but in no event less than the minimum required by the Condominium Act or FNMA/FHLMC from time to time based upon the maximum funds that will be in the custody of the Association or its management agent at any one time. The Association shall bear the cost of bonds.

12.2.6. DIRECTORS AND OFFICERS LIABILITY INSURANCE. The Association shall obtain and maintain directors and officers liability insurance in such amounts as the Board shall deem adequate, utilizing the broad form of policy coverage for all directors and officers and, if reasonably available, committee members of the Association.

12.2.7. ASSOCIATION PROPERTY. Appropriate additional policy provisions, policies or endorsements extending the applicable portions of the coverage described above to all Association Property, where such coverage is available.

12.2.8. OPTIONAL COVERAGE. The Association may purchase and carry such other insurance coverage as the Board of Directors may determine from time to time to be in the best interests of the Association and Unit Owners.

12.3. PROPERTY AND LIABILITY. Except as specifically provided in this Declaration or by the Condominium Act, the Association shall not be responsible to Unit Owners to obtain insurance coverage upon the property lying within the boundaries of their Unit, including, but not limited to, the Unit Owner's personal property, nor insurance for the Unit Owner's personal liability and living expenses nor for any other risks not otherwise insured in accordance herewith. To the extent required by the Condominium Act, each Unit Owner shall maintain insurance for all real and personal property located within the boundaries of the Unit Owner's Unit and all such insurance shall be in a form that complies with the requirements of the Condominium Act.

12.4. DESCRIPTION OF COVERAGE. A detailed summary of the coverage included in the master policies shall be available for inspection by Unit Owners upon request.

12.5. WAIVER OF SUBROGATION. When appropriate and obtainable, each of the foregoing policies shall waive the insurer's right to: (a) subrogation against the Association and against the Unit Owners individually and as a group, (b) pay only a fraction of any loss in the event of coinsurance or if other insurance carriers have issued coverage upon the same risk, and (c) avoid liability for a loss that is caused by an act of the Board of Directors of the Association, a member of the Board of Directors of the Association, one or more Unit Owners or as a result of contractual undertakings. Additionally, each policy shall provide that any insurance trust agreement will be recognized, that the insurance provided shall not be prejudiced by any act or omissions of individual Unit Owners that are not under the control of the Association, and that the policy shall be primary, even if a Unit Owner has other insurance that covers the same loss.

12.6. ADDITIONAL PROVISIONS. All policies of insurance shall provide that such policies may not be canceled or substantially modified without at least thirty (30) days' prior written notice to all of the named insureds, including all mortgagees of Condominium Parcels. Prior to obtaining any policy of casualty insurance or any renewal thereof, the Board of Directors

may (or if required by FNMA/FHLMC, shall) obtain an appraisal from a fire insurance company, or other competent appraiser, of the full insurable replacement value of the Insured Property (exclusive of foundations), without deduction for depreciation, for the purpose of determining the amount of insurance to be effected pursuant to this Section.

12.7. **PREMIUMS.** Premiums upon insurance policies purchased by the Association shall be paid by the Association as a Common Expense, except that the costs of fidelity bonding for any management company employee may be paid by such company pursuant to its contract with the Association. Premiums may be financed in such manner as the Board of Directors deems appropriate.

12.8. **INSURANCE TRUSTEE; SHARE OF PROCEEDS.** All insurance policies obtained by or on behalf of the Association shall be for the benefit of the Association, the Unit Owners and their mortgagees, as their respective interests may appear, and shall provide that all proceeds covering property losses shall be paid to the insurance trustee which may be designated by the Board of Directors (the "Insurance Trustee") as provided in Section 12.12 below, and which, if so appointed, shall be a bank or trust company in Florida with trust powers, with its principal place of business in the State of Florida. The Insurance Trustee shall not be liable for payment of premiums, nor for the renewal or the sufficiency of policies, nor for the failure to collect any insurance proceeds. The duty of the Insurance Trustee shall be to receive such proceeds as are paid and to hold the same in trust for the purposes elsewhere stated herein, and for the benefit of the Unit Owners and their respective mortgagees in the following shares, but shares need not be set forth on the records of the Insurance Trustee:

12.8.1. **INSURED PROPERTY.** Proceeds on account of damage to the Insured Property shall be held in undivided shares for each Unit Owner, such shares being the same as the undivided shares in the Common Elements appurtenant to each Unit, provided that if the Insured Property so damaged includes property lying within the boundaries of specific Units, that portion of the proceeds allocable to such property shall be held as if that portion of the Insured Property were "Optional Property" as subsequently defined.

12.8.2. **OPTIONAL PROPERTY.** Proceeds on account of damage solely to Units and/or certain portions or all of the contents thereof not included in the Insured Property (all as determined by the Association in its sole discretion) (collectively the "Optional Property"), if any is collected by reason of optional insurance which the Association elects to carry thereon (as contemplated herein), shall be held for the benefit of Unit Owners or other portions of the Optional Property damaged in proportion to the cost of repairing the damage suffered by each such affected Unit Owner, which cost and allocation shall be determined in the sole discretion of the Association.

12.8.3. **MORTGAGEES.** No mortgagee shall have any right to determine or participate in the determination as to whether or not any damaged property shall be reconstructed or repaired, and no mortgagee shall have any right to apply or have applied to the reduction of a mortgage debt any insurance proceeds, except for actual distributions thereof made to the Unit Owner and mortgagee pursuant to the provisions of this Declaration.

12.9. DISTRIBUTION OF INSURANCE PROCEEDS. Proceeds of insurance policies received by the Association shall be distributed for the benefit of the Unit Owners in the following manner and priority:

12.9.1. COST OF RECONSTRUCTION OR REPAIR. If the damage for which the proceeds are paid is to be repaired or reconstructed, the proceeds shall first be paid to defray the costs thereof as elsewhere provided in this Declaration. Any proceeds remaining after defraying such costs shall be distributed to the beneficial owners thereof, remittances to Unit Owners and their Mortgagees being payable jointly by them.

12.9.2. FAILURE TO RECONSTRUCT OR REPAIR. If it is determined in the manner elsewhere provided that the damage for which the proceeds are paid shall not be reconstructed or repaired, the proceeds remaining after expenses shall be allocated among the beneficial owners thereof as provided in Section 12.9.1 above and distributed first to all First Mortgagees in an amount sufficient to pay off their Mortgages, and the balance, if any, to the beneficial owners. This is a covenant for the benefit of mortgagees and may be enforced by them.

12.9.3. CERTIFICATE. In making distributions to Unit Owners and their mortgagees, the Insurance Trustee (if appointed) may rely upon a certificate of the Association made by its President and Secretary as to the names of the Unit Owners and their mortgagees and their respective shares of the distribution.

12.10. ASSOCIATION AS AGENT. The Association is hereby irrevocably appointed as agent and attorney-in-fact for each Unit Owner and for each owner of a mortgage or other lien upon a Unit and for each owner of any other interest in the Condominium Property to adjust all claims arising under insurance policies purchased by the Association and to execute and deliver releases upon the payment of claims.

12.11. UNIT OWNERS' PERSONAL COVERAGE. Unless the Association elects otherwise, the insurance purchased by the Association shall not cover claims against a Unit Owner due to accidents occurring within the Unit Owner's Unit, nor casualty or theft loss to the contents of a Unit Owner's Unit. It shall be the obligation of the individual Unit Owner, if such Unit Owner so desires, to purchase and pay for insurance as to all such and other risks not covered by insurance carried by the Association.

12.12. APPOINTMENT OF INSURANCE TRUSTEE. The Board of Directors shall have the option in its discretion of appointing an Insurance Trustee hereunder. If the Association fails or elects not to appoint such Trustee, the Association will perform directly all obligations imposed upon such Trustee by this Declaration. Fees and expenses of any Insurance Trustee are Common Expenses.

12.13. PRESUMPTION AS TO DAMAGED PROPERTY. In the event of a reasonable dispute or reasonable lack of certainty as to whether damaged property constitutes a Unit(s) or Common Elements, such property shall be presumed to be Common Elements.

13. RECONSTRUCTION OR REPAIR AFTER CASUALTY.

13.1. DETERMINATION TO RECONSTRUCT OR REPAIR. Subject to the immediately following paragraph, in the event of damage to or destruction of the Insured Property (and the Optional Property, if insurance has been obtained by the Association with respect thereto) as a result of fire or other casualty, the Board of Directors shall arrange for the prompt repair and restoration of the Insured Property (and the Optional Property, if insurance has been obtained by the Association with respect thereto) and the Insurance Trustee (if appointed) shall disburse the proceeds of all insurance policies to the contractors engaged in such repair and restoration in appropriate progress payments.

If seventy-five percent (75%) or more of the Insured Property (and the Optional Property, if insurance has been obtained by the Association with respect thereto) is substantially damaged or destroyed ("Very Substantial Damage") and if insurance proceeds and reserves available for reconstruction are insufficient to cover the cost of reconstruction and repair of the insured property (and the Optional Property), if insurance has been obtained by the Association with respect thereto and if Unit Owners of at least seventy-five percent (75%) of the Units duly and promptly resolve at a meeting of Unit Owners not to proceed with the repair or restoration thereof and a majority of Institutional First Mortgagees approve such resolution, the Condominium Property will not be repaired and shall be subject to an action for equitable relief, including an action for termination and partition instituted by the Association, any Unit Owner, mortgagee or lienor, as if the Condominium Property were owned in common, in which event the net proceeds of insurance resulting from such damage or destruction shall be divided among all the Unit Owners in proportion to their respective interests in the Common Elements (with respect to proceeds held for damage to the insured property other than that portion of the insured property lying within the boundaries of the Unit), and among affected Unit Owners in proportion to the damage suffered by each such affected Unit Owner, as determined in the sole discretion of the Association (with respect to proceeds held for damage to the Optional Property, if any, and/or that portion of the insured property lying within the boundaries of the Unit); provided, however, that no payment shall be made to a Unit Owner until there has first been paid off out of his share of such funds all mortgages and liens on his Unit in the order of priority of such mortgages and liens.

Whenever in this Section the words "promptly repair" are used, it shall mean that repairs are to begin (subject to delays in processing and obtaining permits and governmental approvals) as soon as reasonably practicable, but, in no event more than one hundred eighty (180) days from the date the Insurance Trustee (if appointed) notifies the Board of Directors and Unit Owners that it holds proceeds of insurance on account of such damage or destruction sufficient to pay the estimated cost of such work, or not more than two hundred ten (210) days after the Insurance Trustee (if appointed) notifies the Board of Directors and the Unit Owners that such proceeds of insurance are insufficient to pay the estimated costs of such work. The Insurance Trustee (if appointed) may rely upon a certificate of the Association made by its President and Secretary to determine whether or not the damaged property is to be reconstructed or repaired.

13.2. PLANS AND SPECIFICATIONS. Any reconstruction or repair must be made substantially in accordance with the plans and specifications for the improvements existing immediately prior to the casualty and then applicable building and other codes; or if not, then in

accordance with the plans and specifications approved by the Board of Directors of the Association and then applicable building and other codes, and, if the damaged property which is to be altered is the Building or the Optional Property, by the Unit Owners of not less than a majority of the Units, as well as the Unit Owners of all Units and other portions of the Optional Property (and their respective mortgagees) the plans for which are to be altered.

13.3. SPECIAL RESPONSIBILITY. If the damage is only to those parts of the Optional Property for which the responsibility of maintenance and repair is that of the respective Unit Owners, then the Unit Owners shall be responsible for all necessary reconstruction and repair, which shall be effected promptly and in accordance with guidelines established by the Board of Directors (unless insurance proceeds are held by the Association with respect thereto by reason of the purchase of optional insurance thereon, in which case the Association shall have the responsibility to reconstruct and repair the damaged Optional Property, provided the respective Unit Owners shall be individually responsible for any amount by which the cost of such repair or reconstruction exceeds the insurance proceeds held for such repair or reconstruction on a Unit by Unit basis, as determined in the sole discretion of the Association). In all other instances, the responsibility for all necessary reconstruction and repair shall be that of the Association.

13.4. DISBURSEMENT. The proceeds of insurance collected on account of a casualty, and the sums collected from Unit Owners on account of such casualty, shall constitute a construction fund which shall be disbursed in payment of the costs of reconstruction and repair in the following manner and order:

13.4.1. If the amount of the estimated costs of reconstruction and repair which are the responsibility of the Association is less than \$100,000.00, then the construction fund shall be disbursed in payment of such costs upon the order of the Board of Directors of the Association; provided, however, that upon request to the Insurance Trustee (if appointed) by an Institutional First Mortgagee which is a beneficiary of an insurance policy, the proceeds of which are included in the construction fund, such fund shall be disbursed in the manner provided in Section 13.4.2.

13.4.2. If the amount of the estimated costs of reconstruction and repair which are the responsibility of the Association is more than \$100,000.00, then the construction fund shall be disbursed in payment of such costs in the manner contemplated by Section 13.4.1 above, but then only upon the further approval or certification of an architect or engineer qualified to practice in Florida and employed by the Association to supervise the work.

13.4.3. If there is a balance of insurance proceeds after payment of all costs of reconstruction and repair that are the responsibility of the Association, such balance may be used by the Association to effect repairs to the Optional Property (if not insured or if under-insured), or may be distributed to Owners of the Optional Property who have the responsibility for reconstruction and repair thereof. The distribution shall be in the proportion that the estimated cost of reconstruction and repair of such damage to each affected Unit Owner bears to the total of such estimated costs to all affected Unit Owners, as determined by the Board; provided, however, that no Unit Owner shall be paid an amount in excess of the estimated costs of repair for his portion of the Optional Property. All proceeds must be used to effect repairs to the

Optional Property, and if insufficient to complete such repairs, the Owners shall pay the deficit with respect to their portion of the Optional Property and promptly effect the repairs. Any balance remaining after such repairs have been effected shall be distributed to the affected Unit Owners and their mortgagees jointly as elsewhere herein contemplated.

13.4.4. It shall be presumed that the first monies disbursed in payment of costs of reconstruction and repair shall be from insurance proceeds. If there is a balance in a construction fund after payment of all costs relating to the reconstruction and repair for which the fund is established, such balance shall be distributed to the beneficial owners of the fund in the manner elsewhere stated; except, however, that part of a distribution to a Unit Owner which is not in excess of Assessments paid by such Unit Owner into the construction fund shall not be made payable jointly to any mortgagee.

13.4.5. Notwithstanding the provisions herein, the Insurance Trustee shall not be required to determine whether or not sums paid by Unit Owners upon Assessments shall be deposited by the Association with the Insurance Trustee, nor to determine whether the disbursements from the construction fund are to be made upon the order of the Association alone or upon the additional approval of an architect, engineer or otherwise, nor whether a disbursement is to be made from the construction fund, nor to determine whether surplus funds to be distributed are less than the Assessments paid by Unit Owners, nor to determine the payees nor the amounts to be paid. The Insurance Trustee may rely upon a certificate of the Association, made by its President or Vice President and Secretary, as to any or all of such matters and stating that the sums to be paid are due and properly payable, and stating the names of the payees and the amounts to be paid.

13.5. ASSESSMENTS. If the proceeds of the insurance are not sufficient to defray the estimated costs of reconstruction and repair to be effected by the Association, or if at any time during reconstruction and repair, or upon completion of reconstruction and repair, the funds for the payment of the costs of reconstruction and repair are insufficient, Special Assessments shall be made against the Unit Owners in sufficient amounts to provide funds for the payment of such costs. Such Assessments on account of damage to the insured property shall be in proportion to all of the Unit Owners' respective shares in the Common Elements, and on account of damage to the Optional Property, the Association shall charge the Unit Owner (but shall not levy an Assessment) in proportion to the cost of repairing the damage suffered by each Unit Owner thereof, as determined by the Association.

13.6. BENEFIT OF MORTGAGEES. Certain provisions in this Section 13, as stated, are for the benefit of mortgagees of Units and may be enforced by any of them.

14. CONDEMNATION.

14.1. DEPOSIT OF AWARDS WITH INSURANCE TRUSTEE. The taking of portions of the Condominium Property or Association Property by the exercise of the power of eminent domain shall be deemed to be a casualty, and the awards for that taking shall be deemed to be proceeds from insurance on account of the casualty and shall be deposited with the Insurance Trustee, if appointed. Even though the awards may be payable to Unit Owners, the Unit Owners shall deposit the awards with the Insurance Trustee; and in the event of failure to do

so, in the discretion of the Board of Directors, a Charge shall be made against a defaulting Unit Owner in the amount of his award, or the amount of that award shall be set off against the sums hereafter made payable to such Unit Owner.

14.2. DETERMINATION WHETHER TO CONTINUE CONDOMINIUM. Whether the Condominium will be continued after condemnation will be determined in the manner provided for determining whether damaged property will be reconstructed and repaired after casualty. For this purpose, the taking by eminent domain also shall be deemed to be a casualty.

14.3. DISBURSEMENT OF FUNDS. If the Condominium is terminated after condemnation, the proceeds of the awards and Special Assessments will be deemed to be insurance proceeds and shall be owned and distributed in the manner provided with respect to the ownership and distribution of insurance proceeds if the Condominium is terminated after a casualty. If the Condominium is not terminated after condemnation, the size of the Condominium will be reduced and the property damaged by the taking will be made usable in the manner provided below. The proceeds of the awards and Special Assessments shall be used for such purposes and shall be disbursed in the manner provided for disbursement of funds by the Insurance Trustee (if appointed) after a casualty, or as elsewhere specifically provided in this Section 14.

14.4. UNIT REDUCED BUT HABITABLE. If the taking reduces the size of a Unit and the remaining portion of the Unit can be made habitable (in the sole opinion of the Association), the award for the taking of a portion of the Unit shall be used for the following purposes in the order stated and the following changes shall be made to the Condominium:

14.4.1. RESTORATION OF UNIT. The Unit shall be made habitable. If the cost of the restoration exceeds the amount of the award, the additional funds required shall be charged to and paid by the Owner of the Unit.

14.4.2. DISTRIBUTION OF SURPLUS. The balance of the award in respect of the Unit, if any, shall be distributed to the Owner of the Unit and to each mortgagee of the Unit, the remittance being made payable jointly to the Owner and such mortgagees.

14.5. UNIT MADE UNINHABITABLE. If the taking is of the entire Unit or so reduces the size of a Unit that it cannot be made habitable (in the sole opinion of the Association), the award for the taking of the Unit shall be used for the following purposes in the order stated and the following changes shall be made to the Condominium:

14.5.1. PAYMENT OF AWARD. The awards shall be paid first to the applicable Institutional First Mortgagees in amounts sufficient to pay off their mortgages in connection with each Unit which is not habitable; second, to the Association for any due and unpaid Assessments; third, jointly to the affected Unit Owners and other mortgagees of their Units. In no event shall the total of such distributions in respect of a specific Unit exceed the market value of such Unit immediately prior to the taking. The balance, if any, shall be applied to repairing and replacing the Common Elements.

14.5.2. ADDITION TO COMMON ELEMENTS. The remaining portion of the Unit, if any, shall become part of the Common Elements and shall be placed in a condition

allowing, to the extent possible, for use by all of the Unit Owners in the manner approved by the Board of Directors of the Association; provided that if the cost of the work therefor shall exceed the balance of the fund from the award for the taking, such work shall be approved in the manner elsewhere required for capital improvements to the Common Elements.

14.5.3. **ASSESSMENTS.** If the balance of the award (after payments to the Unit Owner and such Owner's mortgagees as above provided) for the taking is not sufficient to alter the remaining portion of the Unit for use as a part of the Common Elements, the additional funds required for such purposes shall be raised by Assessments against all of the Unit Owners who will continue as Owners of Units after the changes in the Condominium effected by the taking. The Assessments shall be made in proportion to the applicable percentage shares of those Owners after all adjustments to such shares effected pursuant hereto by reason of the taking.

14.5.4. **ARBITRATION.** If the market value of a Unit prior to the taking cannot be determined by agreement between the Unit Owner and mortgagees of the Unit and the Association within thirty (30) days after notice of a dispute by any affected party, such value shall be determined by arbitration in accordance with the then existing rules of the American Arbitration Association, except that the arbitrators shall be two appraisers appointed by the American Arbitration Association who shall base their determination upon an average of their appraisals of the Unit. A judgment upon the decision rendered by the arbitrators may be entered in any court of competent jurisdiction in accordance with the Florida Arbitration Code. The cost of arbitration proceedings shall be assessed against all Units Owners, including Owners who will not continue after the taking, in proportion to the applicable percentage shares of such Owners as they exist prior to the adjustments to such shares effected pursuant hereto by reason of the taking.

14.6. **TAKING OF COMMON ELEMENTS.** Awards for the taking of Common Elements shall be used to render the remaining portion of the Common Elements usable in the manner approved by the Board of Directors of the Association; provided, that if the cost of such work shall exceed the balance of the funds from the awards for the taking, the work shall be approved in the manner elsewhere required for capital improvements to the Common Elements. The balance of the awards for the taking of Common Elements, if any, shall be distributed to the Unit Owners in the shares in which they own the Common Elements after adjustments to these shares effected pursuant hereto by reason of the taking. If there is a mortgage on a Unit, the distribution shall be paid jointly to the Owner and the mortgagees of the Unit.

14.7. **AMENDMENT OF DECLARATION.** The changes in Units, in the Common Elements and in the ownership of the Common Elements and share in the Common Expenses and Common Surplus that are effected by the taking shall be evidenced by an amendment to this Declaration of Condominium that is only required to be approved by, and executed upon the direction of, a majority of the members of the Board of Directors.

15. USE RESTRICTIONS. The use of the Condominium Property shall be in accordance with the Rules and Regulations and the following provisions:

15.1. **LAWFUL USE.** All valid laws, zoning ordinances and regulations of all governmental bodies having jurisdiction shall be observed. The responsibility of meeting the

requirements of governmental bodies which require maintenance, modification or repair upon Condominium Property shall be the same as the responsibility for the repair and maintenance of the property as expressed earlier in this Declaration.

15.2. RULES AND REGULATIONS. The Rules and Regulations may be amended, and new Rules and Regulations established, from time to time by the Board of Directors. Copies of the regulations and amendments shall be furnished by the Association to all Unit Owners. No new or amended regulation may be enforced prior to distribution to the Unit Owners. Changes in the Rules and Regulations shall not be required to be recorded in the Public Records of the County.

15.3. USE AND OCCUPANCY RESTRICTIONS. Use and occupancy of the Units is restricted to residential uses with one Family and their Guests per Unit only. Occupancy by Guests in the absence of the Unit Owner is limited to two (2) times per calendar year for maximum periods of thirty (30) consecutive days. These use restrictions shall not be construed in such a manner as to prohibit a Unit Owner from maintaining his or her personal professional library, keeping his personal business or professional records or accounts or handling his or her personal, business or professional telephone calls, facsimile or correspondence in and from his or her Unit. Such uses are expressly declared customarily incident to the principal residential use. Notwithstanding the foregoing, the Declarant, its successors and assigns, shall be permitted to use Units which the Declarant owns or leases as model apartments, as sales or other offices or management services, or for overnight accommodations by its designees.

15.4. PETS. Unit Owners may not keep in any Unit or bring upon the Common Elements any animals or pets other than dogs, cats (provided that there shall be no more than one cat or one dog, and no dog shall exceed seventy-five (75) pounds) caged birds and aquarium fish which are usually and commonly kept as household pets, provided that any such permitted pets shall only be allowed to remain in the Unit if such pets are: (i) permitted to be so kept by applicable laws and regulations; (ii) not left unattended on patios or balconies; (iii) not being kept or raised for commercial purposes; and (iv) quiet, inoffensive and not a nuisance or disturbance to residents of other Units or of neighboring Buildings. Each Unit Owner shall be responsible for all damage caused by such Unit Owner's pets. Guests or tenants are not permitted to keep or maintain any pets or animals within Units or bring any pets or animals upon the Condominium Property, unless otherwise permitted by the Board of Directors of the Association. Any Unit Owner who keeps or maintains a pet within a Unit shall indemnify and hold harmless all other Unit Owners, the Declarant and the Association from and against any loss, claim or liability of any kind or character whatsoever arising by reason of keeping or maintaining such pets. Pets shall further be subject to the Rules and Regulations, as enacted and amended from time to time. Without limiting the generality of the other provisions of this Declaration, a violation of the provisions of this paragraph shall entitle the Association to all of its rights and remedies, including, but not limited to, the right to fine Unit Owners and/or to require any pet to be permanently removed from the Condominium Property.

15.5. USE OF COMMON ELEMENTS. The Common Elements shall be used only for furnishing of the services and facilities for which they are reasonably suited and which are incident to the use and occupancy of Units.

15.6. NUISANCES. No nuisances (as defined by the Association) shall be allowed on the Condominium, nor shall any use or practice be allowed which is a source of annoyance to occupants of Units or which interferes with the peaceful possession or proper use of the Condominium by its residents, occupants or members. All parts of the Condominium Property shall be kept in clean and sanitary condition, and no rubbish, refuse or garbage shall be allowed to accumulate nor shall any fire hazard be allowed to exist. No activity specifically permitted by this Declaration shall be deemed a nuisance.

15.7. PROHIBITION OF INCREASES IN INSURABLE RISKS AND CERTAIN ACTIVITIES. Nothing shall be done or kept in any Unit or in or on the Common Elements, or any part thereof, which would result in the cancellation of the insurance on all or any part of the Condominium or in an increase in the rate of the insurance on all or any part of the Condominium over what the Association, but for such activity, would pay, without the prior written approval of the Association. Nothing shall be done or kept in any Unit or in or on the Common Elements which would be in violation of any statute, rule, ordinance, regulation, permit or other imposed requirement of any governmental body. No damage to or waste of the Common Elements shall be committed by any Owner, or by any member of the Owner's family, or by any guest, invitee, customer, contractor, tenant, employee or agent of any Owner, and each Owner shall indemnify and hold the Association and the other Owners harmless against all loss resulting from any such damage or waste caused by such Owner, the members of such Owner's family, or such Owner's guests, invitees, customers, contractors, tenants, employees or agents. Failure to so indemnify shall be a default by such Owner under this Section, and such amount to be indemnified shall automatically become a Special Charge against such Unit Owner.

15.8. ASSOCIATION ACCESS TO UNITS. In order to facilitate access to Units by the Association for the purposes enumerated in Section 9 of this Declaration, it shall be the responsibility of all Unit Owners to deliver a set of keys to their respective Units to the Association to use in the performance of its functions. No Unit Owner shall change the locks to his Unit without so notifying the Association and delivering to the Association a new set of keys to such Unit.

15.9. WINDOW COVERINGS. The covering and appearance of the windows and doors, whether by draperies, shades, reflective film or other items, whether installed within or outside of the Unit, visible from the exterior of the Unit, shall be subject to the Rules and Regulations of the Association.

16. LEASE, CONVEYANCE, DISPOSITION.

16.1. UNITS. The purpose and object of this Section is to maintain a quiet, tranquil, non-transient and single-family oriented atmosphere with the residents living in compatible coexistence with other financially responsible persons who are of like-mind and acceptable both in character and comportment. This objective is considered to be both important and justified because of the necessity of sharing facilities and because of the large personal financial investment of each Unit Owner. Therefore, the lease, conveyance, disposal and financing of the Units by Unit Owners shall be subject to the following provisions:

16.1.1. ASSOCIATION APPROVAL REQUIRED. Except for sales by or to the Declarant, no Unit Owner may sell, lease, give or otherwise transfer ownership of a Unit or any interest therein in any manner without the prior written approval of the Association. Such approval shall be a written instrument in recordable form (except for leases) which shall include, without limitation, the nature of the transfer (sale, lease, etc.), the parties to the transaction (sellers, purchasers, etc.), the Unit number, the name of the Condominium and the Official Record Book (O.R. Book) and Page numbers in which this Declaration was originally recorded. For all Unit transfers of title other than from the Declarant, the approval shall be recorded in the Public Records of the County with the Deed or other instrument transferring title to the Unit. Each new Unit Owner receiving a conveyance from any party except the Declarant shall notify the Association promptly after becoming a new Owner by delivering a copy of the deed to the Unit to the Association.

16.1.2. DEVISE OR INHERITANCE. If any Unit Owner shall acquire title by devise or inheritance or in any other manner not heretofore considered, the continuance of his or her ownership shall be subject to the approval of the Association. Such Unit Owner shall give the Association notice of the acquisition of his title together with such additional information concerning the Unit Owner as the Association may reasonably require together with a copy of the instrument evidencing the Unit Owner's title. If such notice is not given, the Association at any time after receiving knowledge of such transfer, may approve or disapprove the transfer of ownership.

16.1.3. LEASES. Approvals of Leases of Units need not be recorded. Only entire Units may be leased. All Leases of Units must provide, and if they do not, shall be deemed to provide the agreement of the tenant(s) to abide by all of the Condominium Documents. A violation of any of the terms of any of the foregoing documents shall constitute a material breach of the Lease and shall constitute grounds for damages, termination and eviction. The tenant and the Unit Owner agree that the Association may proceed directly against such lessee(s) and that the lessee(s) and the Unit Owner shall be jointly and severally responsible for all of the Association's costs and expenses (including, without limitation, attorneys' fees and costs of any kind, whether at trial or appellate levels or otherwise). If such costs and fees are not immediately paid by the lessee(s), the Unit Owner shall pay them and such funds shall be secured as a Charge. Each Unit Owner irrevocably appoints the Association as the Unit Owner's agent authorized to bring actions in such Unit Owner's name and at such Unit Owner's expense including injunction, damages, termination and eviction. The Rules and Regulations must be provided to the tenant(s) by or on the behalf of the Unit Owner at or before the commencement of the Lease term; provided, however, that tenant(s)' obligations under this Section 16.1.3 shall not be affected by the failure to provide such notice. The minimum leasing period is seven (7) consecutive months, unless made more restrictive by the Board of Directors.

16.1.4. MULTIPLE OWNERS. Consistent with this Section 16, de facto time sharing of Units shall not be permitted and approval will not be given for the sale of a Unit or an interest in a Unit to multiple persons such as (e.g. siblings or business associates), who may intend that they and their families would split occupancy of the Unit into different time periods during the year.

16.1.5. APPROVAL PROCEDURE. The approval of the Association shall be obtained as follows:

16.1.5.1. WRITTEN NOTICE. Not later than thirty (30) days before the proposed transfer of ownership occurs, or fifteen (15) days before the first day of occupancy under a proposed Lease, written notice shall be given the Association by the Unit Owner of his intention to sell or transfer his interest in any fashion. The notice shall include the name and address of the proposed acquirer or lessee and a correct and complete copy of the proposed documents to be executed to effectuate the transaction. The Association may require such other and further information as it deems reasonably necessary and may impose a transfer fee not to exceed \$100.00 or as permitted by law from time to time.

16.1.5.2. ASSOCIATION'S OPTIONS. The Association must, within fifteen (15) days after receipt of all the information required by it, either approve, disapprove for cause, or, except in the case of disapproval for cause, upon the written demand of the Unit Owner, furnish an alternate purchaser or lessor (as the respective case may be), it approves, or the Association may itself elect to purchase or lease the Unit, the Unit Owner shall be compelled to sell or lease, as the case may be, to such alternate purchaser or lessee, or to the Association upon the same terms set forth in the proposal given the Association. Alternatively, the Unit Owner may withdraw the proposed sale or Lease. In exercising its power of disapproval the Association shall act in a manner that is neither arbitrary nor unlawfully discriminatory and withhold approval only for a reason or reasons rationally related to the protection, preservation use and enjoyment of other Unit Owners and lessees and proper operation of the Condominium and the purposes as set forth in this Section 16. If the Association fails or refuses within the allotted time to notify the Unit Owner of either approval or disapproval in writing, or if it fails to provide an alternate purchaser or make an election to purchase the Unit itself when required to do so, then the Association shall conclusively be presumed to have approved the transaction, and the Association shall, upon demand, provide a recordable certificate of approval. In any such case, the Association shall have no responsibility for the Unit Owner's costs, brokerage fees, attorneys' fees and costs or any other claims related to a delay or failure in closing of the sale or lease of the respective Unit.

16.1.5.3. CLOSING DATE. If the Association provides an alternative, the sale or lease shall be closed within sixty (60) days after an alternate purchaser has been furnished or the Association has elected to purchase.

16.1.5.4. NOTICE OF DISAPPROVAL. If the Association disapproves the proposed transaction (subject to the qualifications contained in Section 16.1.5.2.) notice of disapproval shall be promptly sent in writing to the Unit Owner or interest holder, and the transaction shall not be completed.

16.1.6. JUDICIAL SALES. Judicial sales are exempt from this Section. A transfer to or a transfer by a Institutional First Mortgagee that acquires its title as the result of a deed from its mortgagor in lieu of foreclosure or through foreclosure proceedings shall be exempt from the provisions of this Section and such transaction shall not require approval of the Association. The purchaser from a Institutional First Mortgagee shall not be subject to approval by the Association as provided in this Section.

16.2. **VOID TRANSACTIONS.** Any residential transaction for which the Association's approval is not obtained pursuant to the terms of this Declaration shall be void unless subsequently approved by the Association.

17. COMPLIANCE AND DEFAULT. Each Unit Owner, each tenant and other invitee shall be governed by, and shall comply with the provisions of, the Condominium Act as amended from time to time, the Condominium Documents, the Rules and Regulations, and any and all other rules and regulations of the Association promulgated and amended from time to time.

17.1. **REMEDIES.** Failure to comply shall be grounds for relief, which relief may include, but shall not be limited to, an action to recover damages or injunctive relief or both. Actions may be maintained by the Association or by any Unit Owner.

17.2. **COSTS AND FEES.** In any such proceeding, including appeals, the prevailing party shall be entitled to recover the costs of the proceeding and reasonable attorneys' fees.

17.3. **OWNER INQUIRIES; DISPUTES.** In the event of an inquiry by a Unit Owner against the Association, the Board of Directors or a member thereof, such aggrieved Unit Owner, prior to the institution of any proceedings, shall give written notice in detail of the inquiry by certified mail to the Board of Directors. The Board shall respond in writing to the Unit Owner within thirty (30) days of the receipt of the inquiry. The Board's response shall either give a substantive response to the inquirer, notify the inquirer that a legal opinion has been requested, or notify the inquirer that advice has been requested from the Division of Condominiums. If the Board requests advice from the Division of Condominiums, the Board shall, within ten (10) days of receipt of the advice, provide in writing a substantive response to the inquirer. If a legal opinion is requested, the Board shall, within sixty (60) days of the receipt of the inquiry, provide in writing a substantive response to the inquirer. The failure to act as above set forth precludes the Association from recovering attorney's fees and costs in any subsequent litigation, administrative proceedings, or arbitration arising out of the inquiry. If unresolved, a dispute as defined in Section 718.1255(1) of the Condominium Act shall be subject to an arbitration in mandatory non-binding arbitration proceedings (in accordance with Section 718.1255(1) of the Condominium Act) prior to commencing litigation.

17.4. **NO WAIVER OF RIGHTS.** The failure of the Association or any Unit Owner to enforce any covenant, restriction or other provision of the Condominium Documents shall not constitute a waiver of the right to do so thereafter as to subsequent or other instances.

17.5. **LIEN RIGHTS.** The provisions of this Section 17 shall not limit or impair the right to impose, enforce and foreclose upon liens in connection with unpaid Assessments or otherwise, to the extent otherwise permitted under this Declaration or the Condominium Act.

18. AMENDMENTS. Amendments to any of the Condominium Documents shall be in accordance with the following:

18.1. AMENDMENT BY UNIT OWNERS.

18.1.1. An amendment to this Declaration of Condominium may be proposed by the Board of Directors acting upon a vote of a majority of the Directors or by Unit Owners owning not less than fifty-one percent (51%) of the Units, whether by vote at a meeting of members or by an instrument in writing signed by them. A proposal to amend this Declaration of Condominium shall contain the full text of the provision to be amended. New words shall be inserted in the text and underlined or highlighted and words to be deleted shall be lined through with hyphens. However, if the proposed change is so extensive that this procedure would hinder, rather than assist, the understanding of the proposed amendment, it shall not be necessary to use underlining and hyphens as indicators of words added or deleted, but, instead, a notation shall be inserted immediately preceding the proposed amendment in substantially the following language:

“Substantial re-wording of Declaration of Condominium. See Article _____ for present text.”

18.1.2. The proposed amendment shall be transmitted to the President of the Association, or in such person's absence, to the Vice President of the Association, who shall thereupon call a special meeting of the Unit Owners for a date not sooner than twenty (20) days nor later than sixty (60) days from receipt by such officer of the proposed amendment. It shall be the duty of the Secretary or other appropriate officer of the Association to give to each Unit Owner written notice of the special meeting, together with a copy of the proposed amendment in the form above provided, which notice shall be delivered or mailed not less than fourteen (14) days nor more than thirty (30) days before the date set for the special meeting. If mailed, the notice shall be deemed properly given when deposited in the United States mail addressed to the member at his, her or its post office address as it appears on the records of the Association. Any Unit Owner may, by written waiver of notice signed by such Unit Owner, waive such notice, and such waiver, when filed in the records of the Association, whether before or after the holding of the meeting, shall be deemed equivalent to the giving of such notice to such Unit Owner. Notice of the meeting shall be posted in a conspicuous place on the Common Elements at least fourteen (14) days before the special meeting.

18.1.3. At the special meeting called to consider a proposed amendment, such amendment must be approved by an affirmative vote of Unit Owners owning not less than sixty-six percent (66%) of the Units; provided, however, no amendment may be adopted which adversely affects any of the rights and/or privileges provided to the Declarant without the written consent of the Declarant. In the alternative, a proposed amendment may be adopted without the holding of a special meeting if within ninety (90) days from the mailing or delivery thereof to all Unit Owners the amendment is approved in writing by members of the Association owning not less than sixty-six percent (66%) of the Units; provided, however, no amendment may be adopted which adversely affects any of the rights and/or privileges provided to the Declarant without the written consent of the Declarant. If the amendment shall be adopted by either method, such amendment shall be transcribed and certified by the President and Secretary of the Association as having been so adopted. The certificate of amendment shall include the recording

data identifying this Declaration of Condominium, shall be executed in the form required for execution of a deed and shall be recorded in the Public Records of the County within ten (10) days from the date of adoption and shall become effective on the date of recording. A copy of the amendment in the form in which it has been placed of record shall be delivered to all Unit Owners, but delivery of such copies shall not be a condition precedent to the effectiveness of the amendment. At any meeting held to consider a proposed amendment, the written vote of any Unit Owners shall be recognized if the Unit Owners are not in attendance at the meeting or represented by limited proxy, provided such written vote is delivered to the Secretary of the Association prior to the meeting or at such meeting.

18.2. AMENDMENT BY THE DECLARANT. Except as set forth in Section 18.3, and except for amendments relating to matters described in Section 718.110(4), Section 718.110(8) and Section 718.110(13) of the Condominium Act, during the time the Declarant has the right to elect a majority of the Board of Directors of the Association, the Declaration, the Articles of Incorporation, the By-Laws and the Rules and Regulations of the Association may be amended by the Declarant alone, without requiring the consent of any other party to effect any change whatsoever. In any case, no amendment may be adopted which would eliminate, modify, prejudice, abridge or otherwise adversely affect any rights, benefits, privileges or priorities granted or reserved to the Declarant, without the consent of the Declarant in each instance. This paragraph shall take precedence over any other provision of this Declaration or its exhibits.

18.3. ADDITIONAL REQUIREMENTS FOR CERTAIN AMENDMENTS. Notwithstanding anything contained in this Declaration of Condominium to the contrary:

18.3.1. No alteration in the percentage of ownership in Common Elements appurtenant to each Unit, alteration of the basis for the sharing of Common Expenses and apportionment of Assessments, alteration of the basis of ownership of Common Surplus, or alteration or modification of the appurtenances to any Unit, shall be made without the joinder in the amendment of all Owners of the Units affected and all record owners of liens on such Units (which consent may not be unreasonably withheld) and the amendment is otherwise approved by sixty-six percent (66%) or more of the Voting Interests.

18.3.2. Alterations, amendments or modifications under and to this Declaration of Condominium shall require the consent of some or all Institutional First Mortgagees, if, and only to the extent that, such alteration, amendment or modification would materially affect the rights or interest of a respective Institutional First Mortgagee, or if the consent of a respective Institutional First Mortgagee is required by the Federal National Mortgage Association or the Federal Home Loan Mortgage Corporation. The consent of a First Mortgagee shall not be unreasonably withheld or delayed. It shall be presumed that, except as to those matters described in Section 718.110(4) and Section 718.110(8) of the Condominium Act, amendments to this Declaration do not materially affect the rights or interests of mortgagees.

18.3.3. No alteration, amendment or modification of the rights and privileges of the Declarant under this Declaration of Condominium or any other Condominium Document, nor any amendment thereto, which would adversely affect the sale of Units owned by the Declarant as determined by the Declarant in its reasonable discretion, shall be made without the prior written consent of the Declarant.

18.3.4. Any amendment that further restricts Unit Owners' rights relating to the rental of Units is subject to the provisions of Section 718.110(13) of the Condominium Act.

18.4. AMENDMENT IN NATURE OF CORRECTION. Whenever it shall appear that there is a defect, error or omission in any of the Condominium Documents or in order to comply with applicable laws or requirements of government entities, the amendment may be adopted by the Board of Directors alone.

18.5. MERGER AMENDMENT. In the event that this Condominium should desire to merge with one or more other condominiums within it may do so upon the affirmative vote of seventy-five percent (75%) of the Voting Interests in this Condominium and the approval of all record owners of liens. When the Board intends to merge the Condominium or the Association, the Board shall notify the Division of Condominiums before taking any action to merge the Condominium or the Association.

18.6. DECLARANT AMENDMENTS. Until relinquishment of Declarant control of the Association and except as otherwise provided by law in Section 718.110(2) of the Condominium Act, the Declarant specifically reserves the right, without the joinder of any person, to make such amendments to the Declaration and its exhibits or to the plan of development, as may be required by any lender, governmental authority or as may be, in its judgment, necessary or desirable. This paragraph shall take precedence over any other provision of this Declaration or its exhibits.

18.7. WRITTEN AGREEMENTS. Any approval of Unit Owners on any matter called for by this Declaration, any of the other Condominium Documents, or any statute to be taken at a meeting of Unit Owners is hereby expressly allowed to be taken instead by written agreement, without a meeting (which agreement may be in counterparts), subject to Section 718.112(2)(d)(4) of the Condominium Act and Florida Statutes Section 617.0701(in effect as of the date of this Declaration).

19. TERMINATION. Except for termination in connection with a merger of this Condominium with another, as provided for in Section 18.5., the termination of the Condominium shall be carried out in accordance with the following:

19.1. BY AGREEMENT. The Condominium may be caused to be terminated at any time by written agreement of Unit Owners representing one hundred percent (100%) of the Units and their respective Institutional First Mortgagees, if any.

19.2. WITHOUT AGREEMENT, ON ACCOUNT OF VERY SUBSTANTIAL DAMAGE. If the Condominium suffers Very Substantial Damage and it is not decided, pursuant to the terms of Section 13.1 as therein provided, that the Condominium will be

reconstructed or repaired, the condominium form of ownership of the property in this Condominium will be terminated.

19.3. PROCESS OF TERMINATION. When the Board intends to terminate the Condominium, the Board shall notify the Division of Condominiums before taking any action to terminate the Condominium. Termination of the Condominium shall occur when a Certificate of Termination meeting the requirements of this Section and the Condominium Act is recorded in the Public Records of the County.

19.3.1. The termination of the Condominium shall be evidenced by a Certificate of Termination, executed by the President or Vice-President with the formalities of a deed, and certifying as to the facts effecting the termination. The Certificate shall also include the name and address of a Florida financial institution with trust powers, or a licensed Florida attorney, who is designated by the Association to act as the termination trustee, and shall be signed by the trustee (the "Termination Trustee") indicating willingness to serve in that capacity. Upon recordation of the Certificate of Termination in the public records of the County, the Association, within thirty (30) business days of such filing, shall notify the Division of Condominiums of the termination and the date the Certificate of Termination was recorded, the county where the Certificate of Termination was recorded, and the book and page number of the public records where the Certificate of Termination was recorded, and shall provide the Division of Condominium a copy of the Certificate of Termination certified by the clerk.

19.3.2. The recording of a Certificate of Termination shall automatically divest the Association of title to all Association Property, and divest all Unit Owners of legal title to their respective Condominium Parcels, and shall vest legal title in the Termination Trustee named in the Certificate of Termination, to all real and personal property which was formerly the Condominium Property or Association Property, without need for further conveyance. Beneficial title to the former Condominium and Association Property shall be transferred to the former Unit Owners as tenants in common, in the same undivided shares as each Unit Owner previously owned in the Common Elements, without further conveyance. Each lien encumbering a Condominium Parcel shall be automatically transferred to the equitable interest in the former Condominium Property and Association Property attributable to the Unit encumbered by the lien, with the same priority.

19.4. WIND-UP OF ASSOCIATION AFFAIRS. The termination of the Condominium shall not, by itself, terminate the Association. The former Unit Owners and their successors and assigns shall continue to be members of the Association, and the members of the Board of Directors and the officers of the Association shall continue to have the powers granted in this Declaration, the Articles of Incorporation, the By-Laws and the Condominium Act, to the extent necessary to, and for the sole purpose of, winding up the affairs of the Association in accordance with this Section.

19.5. TRUSTEE'S POWERS AND DUTIES. The Termination Trustee shall hold legal title to the Condominium or Association Property or both for the benefit of the former Unit Owners and their successors, assigns, heirs, devisees, mortgagees and other lien holders, as their interests shall appear. If the former Unit Owners approve a sale of the Condominium or Association Property or both as provided in this Section, the Termination Trustee shall have the

power and authority to convey title to the purchaser(s), and to distribute the proceeds in accordance with the provisions of this Section. The Termination Trustee may charge a reasonable fee for acting in such capacity, and such fee, as well as all costs and expenses incurred by the Termination Trustee in the performance of its duties, shall be paid by the Association or taken from the proceeds of the sale of the former Condominium and Association Property, and shall constitute a lien on the Condominium or Association Property or both superior to any other lien. The Termination Trustee shall be entitled to indemnification by the Association from any and all liabilities and costs incurred by virtue of acting as Termination Trustee unless such liabilities are the result of gross negligence or willful misconduct.

19.6. RELIANCE. The Termination Trustee may rely upon the written instructions and information provided to it by the officers, directors and agents of the Association, and shall not be required to inquire beyond such information and instructions.

19.7. PARTITION; SALE. Following termination, the former Condominium Property and Association Property may be partitioned and sold upon the application of any Unit Owner. If following a termination, at least seventy-five percent (75%) of the Unit Owners agree to accept an offer for the sale of the Condominium or Association Property or both, the Board of Directors shall notify the Termination Trustee, and the Termination Trustee shall complete the transaction. In such event, any action for partition of the Condominium or Association Property shall be held in abeyance pending the sale, and upon the consummation of the sale shall be discontinued by all parties thereto. If the Unit Owners have not authorized a sale of the former Condominium and Association Property within one (1) year after the recording of the Certificate of Termination, the Trustee may proceed to sell the Condominium or Association Property without agreement by the Association or the former Unit Owners. The net proceeds of the sale of any of the Condominium or Association Property or assets of the Condominium or the Association shall be distributed by the Termination Trustee to the beneficial owners thereof, as their interests shall appear.

19.8. NEW CONDOMINIUM. The termination of the Condominium shall not bar creation of another Condominium including all or any portion of the Condominium or Association property.

19.9. PROVISIONS SURVIVE TERMINATION. The provisions of this Section 19 are covenants running with the land, and shall survive the termination of the Condominium until all matters covered by those provisions have been completed. The Board of Directors shall continue to function in accordance with the By-Laws and Articles of Incorporation, and shall have the power to levy Assessments to pay the costs and expenses of the Termination Trustee and of maintaining the Condominium or Association Property until it is sold. The costs of termination, the fees and expenses of the Termination Trustee, as well as post-termination costs of maintaining the former Condominium Property, are Common Expenses, the payment of which shall be secured by a lien on the beneficial interest owned by each former Unit Owner, which to the maximum extent permitted by law, shall be superior to, and take priority over, all other liens.

20. PROVISIONS PERTAINING TO THE DECLARANT.

20.1. CONSTRUCTION, DEVELOPMENT, SALES. In addition to all other rights granted or reserved to the Declarant in this Declaration of Condominium, the Articles of

Incorporation and the By-Laws of the Association, the Declarant shall have the right to conduct on the Condominium Property, all operations necessary, in its sole discretion, to complete the construction and development of the Condominium and to market, sell and lease the Units. Irrespective of any restriction or regulation, the Declarant or its agents may enter upon the Condominium Property and operate thereon such vehicles and equipment as shall be necessary in the sole discretion of the Declarant or its agents for such purposes. The Declarant shall have the right to use any Unit or other portion of the Condominium Property as a model Unit and/or sales office in connection with the Declarant's program to sell or lease Units and shall have the right to place upon the Common Elements signs designating the Declarant's model condominiums and/or sales office and advertising for sale or lease Units owned by the Declarant. Such signs may be placed in such locations and shall be of such size and character as the Declarant may determine.

20.2. REPRESENTATION ON BOARD OF DIRECTORS; VOTING BY DECLARANT. The Declarant shall have the right to select and designate members of the Board of Directors of the Association, and to remove and replace any person or persons selected by the Declarant as a member of the Board of Directors, as provided in the Articles of Incorporation and By-Laws. No representative of the Declarant serving on the Board of Directors of the Association shall be required to disqualify herself or himself from voting on any contract or other matter between the Declarant and the Association notwithstanding any pecuniary or other interest of the Declarant. The Declarant shall not be disqualified from voting on any matter which may come before the membership of the Association with respect to any contract or other matter between the Declarant and the Association, notwithstanding any pecuniary or other interest of the Declarant. Directors appointed by Declarant shall not be required to be owners or residents of Units in the Condominium. At least a majority of the Board of Directors who are elected by the members of the Association shall be owners of Units in the Condominium or shall be authorized representatives, officers or employees of a corporation or other organization which is the owner of a Unit.

20.3. DISSOLUTION OR MERGER OF DECLARANT. In the event of the dissolution of the Declarant or its merger or consolidation into any other entity which survives the Declarant, all rights of the Declarant under this Declaration of Condominium or any other Condominium Document shall pass to and may be exercised by its successor or survivor.

20.4. ASSIGNABILITY OF THE DECLARANT'S STATUS. The status, position and rights of the Declarant under this Declaration of Condominium, the Articles of Incorporation and the By-Laws of the Association are freely assignable, in whole or in part, and any party to whom assigned shall be entitled to exercise all of the rights so assigned. The Declarant shall have the right to appoint and designate a successor who shall succeed to the status, position and all of the rights and privileges of the Declarant under this Declaration of Condominium by a written instrument identifying and designating such successor executed in recordable form and, upon the recording of such instrument in the Public Records of the County, the party named as successor shall succeed to all of the rights, privileges, exemptions and immunities of the Declarant under this Declaration of Condominium.

20.5. ASSESSMENT FOR CAPITAL IMPROVEMENTS; ACTIONS DETRIMENTAL TO SALES. Notwithstanding any other provision of this Declaration of

Condominium or any other Condominium Document, so long as the Declarant holds a Unit or Units for sale in the ordinary course of business, none of the following actions may be taken without approval in writing by the Declarant:

20.5.1. Assessment of the Declarant as a Unit Owner for capital improvements or capital additions; and

20.5.2. any action by the Association which would be detrimental to the sales of Units by the Declarant or the completion of the Condominium by the Declarant, including such use of unsold Units and Common Elements and Association Property as may facilitate completion, sale, maintenance of a sales office, showing of the Property and display of signs; provided, an increase in Assessments for Common Expenses without discrimination against the Declarant shall not be deemed detrimental to the sales of Units.

20.6. **CHANGES IN UNITS.** The Declarant shall have the right, without the vote or consent of the Association or other Unit Owners, to (i) make alterations, additions or improvements in, to and upon Units owned by the Declarant, whether structural or non-structural; and (ii) change the floor plan and lay-out of any Unit owned by the Declarant; provided, however, that all material changes to the configuration or size of any Unit shall require the approval of members of the Association owning a majority of all of the Units in the Condominium. However, in no event shall any such alteration, improvement change or combination interfere with the structural support of any Unit or the Common Elements or Limited Common Elements or the provision of utility service to any Unit, the Common Elements or Limited Common Elements, although Common Elements contained in walls, floors and ceilings between Units being combined may be penetrated or eliminated. The combination of Units shall not affect the interest in Common Elements, the share of Common Expense and Common Surplus or the voting rights appurtenant to the combined Unit which shall be treated for all such purposes as separate Units. Subject to the provisions of this Declaration, any Units combined may subsequently, at the expense of the Unit Owners thereof, be separated into separate and "discreet" or "distinct" Units as originally set forth in the Condominium Plot Plan; upon the approval of members of the Association owning not less than fifty-one percent (51%) of the Units in the Condominium. All work done in accordance with the provisions of this Article shall be done in compliance with all applicable laws and governmental regulations. Notwithstanding the provisions of Section 8.4 to the contrary, Declarant may not change the configuration or size of any Condominium Unit in any material fashion, materially alter or modify the appurtenances to the Unit, or change the proportion or percentage by which the owner of the Unit shares Common Expenses and owns the Common Surplus, unless the Declarant complies with the provisions of Section 718.110(4) of the Condominium Act.

21. RIGHTS OF MORTGAGEES.

21.1. **RIGHTS TO INFORMATION.** Upon receipt by the Association from any Institutional First Mortgagee, guarantor or insurer of a copy of the mortgage held by such mortgagee, guarantor or insurer on a Unit, together with a written request from such mortgagee, or a guarantor or insurer of such mortgagee specifying the address to which the following items are to be sent, the Association shall timely send to such mortgagee, insurer or guarantor the following, and for which the Association may charge a reasonable fee:

21.1.1. a copy of a financial statement of the Association for the immediately preceding fiscal year;

21.1.2. written notice of the cancellation or termination by the Association of any policies of insurance covering the Condominium Property or the Association Property or any improvements thereon, or any fidelity bonds of the Association, except when the reason for the termination or cancellation of the insurance policy or bond is to change insurance companies or because the policy or bond is not needed or is not available;

21.1.3. written notice of any damage or destruction to the Common Elements, Limited Common Elements or Condominium Property or the Association property which affects a material portion of the Common Elements, Limited Common Elements or Condominium Property or the Association Property or the Unit securing its mortgage;

21.1.4. written notice of a condemnation or eminent domain proceeding affecting a material portion of the Condominium Property or the Unit securing its mortgage; and

21.1.5. written notice of failure by the Owner of a Unit encumbered by a first mortgage held by such institutional mortgagee, guarantor or insurer to pay any Assessments when such failure or delinquency has continued for a period of sixty (60) days or longer.

21.2. **FAILURE TO NOTIFY.** The failure of the Association to send any such notice to any such mortgagee, guarantor or insurer shall have no effect on any meeting, action or thing which was to have been the subject of such notice nor affect the validity thereof and shall not be the basis for liability on the part of the Association.

22. ASSOCIATION AGREEMENTS. The Association is authorized to enter into agreements to acquire leaseholds, memberships, and other possessory or use interest in lands or facilities such as country clubs, golf courses, marinas, and other facilities. Such interests need not be contiguous to the Property if they are intended to provide enjoyment, recreation, or other use or benefit to the Unit Owners.

23. DISCLAIMER OF WARRANTIES. Declarant hereby disclaims any and all and each and every express or implied warranties, whether established by statutory, common, case law or otherwise, as to the design, construction, continuation of any particular view (it being understood and agreed that construction on any adjacent properties may obstruct such view), sound and/or odor transmission or furnishing and equipping of the Condominium Property, including, without limitation, any implied warranties of habitability, fitness for a particular purpose or merchantability, compliance with plans, all warranties imposed by statute (other than those imposed by Section 718.203 of the Condominium Act, and then only to the extent applicable and not yet expired) and all other express and implied warranties of any kind or character. As to such warranties which cannot be disclaimed, and to other claims, if any, which can be made as to the aforesaid matters, all incidental and consequential damages arising therefrom are hereby disclaimed.

All Unit Owners, by virtue of acceptance of title to their respective units (whether from the Declarant or another party) shall be deemed to have automatically waived all of the aforesaid disclaimed warranties and incidental and consequential damages.

Lastly, each Unit Owner, by acceptance of a deed or other conveyance of a Unit, understands and agrees that there are various methods for calculating the square footage of a Unit, and that depending on the method of calculation, the quoted square footage of the Unit may vary by more than a nominal amount. Additionally, as a result of field construction, other permitted changes to the Unit, and settling and shifting of improvements, actual square footage of a Unit may also be affected. By accepting title to a Unit, the applicable Unit Owner(s) shall be deemed to have conclusively agreed to accept the size and dimensions of the Unit, regardless of any variances in the square footage from that which may have been disclosed at any time prior to closing, whether included as part of the Declarant's promotional materials or otherwise.

24. INDEMNIFICATION OF OFFICERS AND DIRECTORS. The Association shall indemnify its directors, officers and committee members and may indemnify its employees and agents, to the fullest extent permitted by law against any and all expenses or liabilities incurred in defending civil, criminal or administrative proceedings resulting from the performance or attempted performance in good faith of their offices on behalf of the Association or its members. Such indemnification shall include advancement of expenses prior to the final disposition of any such proceedings and amounts paid in settlement of such proceedings, and such indemnification shall not be deemed exclusive of any other rights to which those indemnified may be entitled under any document other than this Declaration of Condominium, by vote of the members or disinterested directors, or otherwise. This indemnification shall continue as to a person who has ceased to be a director, officer, committee member, employee or agent, and shall inure to the benefit of his or her heirs and personal representatives.

25. ACCESS MONITORING. The Association may maintain or support certain activities in the Condominium designed to make the Units and the Occupants safer than they otherwise might be. However, the Declarant and the Association shall have no obligation to undertake, maintain or support such activities nor shall they and their respective predecessors, successors, employees, officers, directors, affiliates, contractors or agents be considered insurers or guarantors (collectively, the "Companies") of security in the Condominium, nor be held liable for any loss or damage by reason of failure to provide adequate security or the ineffectiveness of any security measures undertaken. All Unit Owners and occupants of any Unit, and all guests and invitees of any Unit Owner or occupant, acknowledge that the Declarant, the Association, and the Companies do not represent or warrant that any fire protection system, burglar alarm system or other security system or device installed or employed may not be compromised or circumvented, that any such system will prevent loss by fire, smoke, burglary, theft, hold-up or otherwise, nor that any such system will in all cases provide the detection or protection for which the system is designed or intended. Unit Owners and occupants of any Unit and their guests and invitees are hereby put on notice of the provisions of this section and acknowledge by taking title or occupancy that the Declarant, the Association and the Companies are not insurers and that each Unit Owner and occupant and his, her or its tenants, guests and invitees assume all risks for loss or damage to persons, Units and the contents of Units and property brought on the Condominium. The Declarant, the Association and the Companies make no representation or warranty, express or implied, including any warranty of merchantability or fitness for any particular purpose, with respect to any fire or burglar alarm system or other security system installed or employed in the Condominium.

26. SEVERABILITY AND NON-WAIVER. If any provision of this Declaration or its exhibits as now constituted or as later amended or any section, sentence, clause, phrase or word, or the application thereof in any circumstances is held invalid, the validity of the remainder and of the application of any such provision, section, sentence, clause, phrase or word in other circumstances shall not be affected thereby.

[Signatures appear on the following pages]

THIS DECLARATION OF CONDOMINIUM and exhibits hereto made and entered into this 5th day of January, 2006.

Declarant hereby activates the guarantee in Section 11.1 above.

WITNESSES:

(Sign) *Iliana Cuadros*
(Print) Iliana Cuadros

(Sign) *Chris Knecht*
(Print) CHRIS KNECHT

HERITAGE DEERWOOD CONDOMINIUM,
LLC, a Delaware limited liability company

By: *Todd Caplin*
Name: Todd Caplin
Title: Managing Member

1500 San Remo Avenue, Suite 201
Coral Gables, Florida 33146

STATE OF FLORIDA)
) ss:
COUNTY OF Dade)

The foregoing instrument was acknowledged before me this 5th day of January, 2006, by Todd Caplin, as the managing member of Heritage Deerwood Condominium, LLC, on behalf of said limited liability company. He is personally known to me or has produced _____ as identification.

(Notarial Seal)

My Commission Expires:



ILJANA R. CUADROS
MY COMMISSION # DD 494075
EXPIRES: November 29, 2009
Bonded Thru Budget Notary Services

Name: *Iliana Cuadros*
Commission No.: _____
Notary Public, State of _____

JOINDER

HERITAGE DEERWOOD CONDOMINIUM ASSOCIATION, INC., a Florida not-for-profit corporation (the "Association"), hereby joins in and agrees to accept all of the benefits and duties, responsibilities, obligations and burdens imposed upon it by the provisions of this Declaration and Exhibits attached hereto.

IN WITNESS WHEREOF, the Association has caused these presents to be signed by its proper officer and its corporate seal to be affixed this 5th day of January, 2006.

Witnessed by:

HERITAGE DEERWOOD
CONDOMINIUM ASSOCIATION, INC., a
Florida not-for-profit corporation

Iliana Cuadros
Name: Iliana Cuadros

By: *Todd Caplin*
Name: Todd Caplin
Title: President

CARIS WJECHT
Name: CARIS WJECHT

1500 San Remo Avenue, Suite 201
Coral Gables, Florida 33146

STATE OF FLORIDA)
) ss:
COUNTY OF Dade)

The foregoing instrument was acknowledged before me this 5th day of January, 2006 by Todd Caplin, as President of HERITAGE DEERWOOD CONDOMINIUM ASSOCIATION, INC., a Florida corporation not for profit, on behalf of the corporation. He is personally known to me or has produced _____ as identification.

(Notarial Seal)



ILIANA R. CUADROS
MY COMMISSION # DD 494075
EXPIRES: November 29, 2009
Bonded Thru Budget Notary Services

My Commission Expires:

Name: *Iliana Cuadros*
Commission No.: _____
Notary Public, State of _____

CONSENT OF MORTGAGEE

regarding recordation of Declaration of Condominium
of Heritage Deerwood, a Condominium

CORUS BANK, N.A. (the "Mortgagee"), the holder of the Mortgage executed by Heritage Deerwood Condominium, LLC ("Declarant") in favor of Mortgagee dated August 17, 2005 and recorded in Official Records Book 12706, Page 540 of the Public Records of Duval County, Florida, which Mortgage constitutes a lien and encumbrance upon the real property described in the within and the foregoing Declaration of Condominium of Heritage Deerwood, a Condominium (the "Declaration"), hereby consents to Declarant subjecting the real property described in the Declaration to the provisions of the Declaration and agrees that the Declaration shall be binding upon the present and future owners of the real property covered by the Declaration.

Notwithstanding the execution of this consent, nothing herein shall be construed to render the Mortgagee responsible or liable for the performance of any of the covenants or undertakings of the Declarant under the Declaration nor shall this consent affect the priority of lien of the Mortgage or the interest of the Mortgagee.

Dated this 6th day of January, 2006.

Witnessed by:

CORUS BANK, N.A.

Cathy Suciich

Name: Cathy Suciich

Daniel Kraski

Name: Daniel Kraski

By: John P. Ascher

Name: John P. Ascher

Title: First Vice President

Address: Corus Bank, N.A.
3959 North Lincoln Avenue
Chicago, IL 60613

STATE OF ILLINOIS)
) SS:
COUNTY OF COOK)

The foregoing instrument was acknowledged before me this 6th day of JANUARY, 2006, by JOHN P. ASCHER as FIRST VICE PRESIDENT of CORUS BANK, N.A., on behalf of said BANK. He/~~she~~ is personally known to me or produced _____ as identification.

(Notarial Seal)

My Commission Expires



Name: Rose Odeschko

Commission No.: _____

Notary Public, State of _____

EXHIBIT "A"

A PORTION OF SECTION 18, TOWNSHIP 3 SOUTH, RANGE 28 EAST, JACKSONVILLE, DUVAL COUNTY, FLORIDA, BEING MORE PARTICULARLY DESCRIBED AS FOLLOWS:

FOR THE POINT OF BEGINNING, COMMENCE AT THE POINT OF INTERSECTION OF THE NORTHERLY EXTENSION OF THE CENTERLINE OF ROYAL CREST DRIVE, A 100 FOOT RIGHT OF WAY, ACCORDING TO PLAT OF JAMES ISLAND UNIT ONE AS RECORDED IN THE CURRENT PUBLIC RECORDS OF JACKSONVILLE, DUVAL COUNTY, FLORIDA IN PLAT BOOK 52, PAGES 65, 65A THROUGH 65H, WITH THE NORTHERLY RIGHT OF WAY LINE OF BURNT MILL ROAD, A VARIABLE WIDTH RIGHT OF WAY ACCORDING TO PLAT OF GATE PARKWAY EXTENSION AS RECORDED IN SAID PUBLIC RECORDS IN PLAT BOOK 52, PAGES 55, 55A THROUGH 55K, AND RUN SOUTH $89^{\circ}51'26''$ WEST, ALONG SAID NORTHERLY RIGHT OF WAY LINE, A DISTANCE OF 214.54 FEET TO A POINT; THENCE DEPARTING SAID NORTHERLY RIGHT OF WAY LINE, RUN NORTH $00^{\circ}08'34''$ WEST A DISTANCE OF 836.00 FEET TO A POINT; RUN THENCE NORTH $89^{\circ}51'26''$ EAST A DISTANCE OF 1146.00 FEET TO A POINT; RUN THENCE SOUTH $00^{\circ}08'34''$ EAST A DISTANCE OF 836.00 FEET TO A POINT IN THE AFOREMENTIONED NORTHERLY RIGHT OF WAY LINE OF BURNT MILL ROAD; RUN THENCE SOUTH $89^{\circ}51'26''$ WEST, A DISTANCE OF 931.46 FEET TO THE POINT OF BEGINNING.

EXHIBIT "B" HERITAGE DEERWOOD, A CONDOMINIUM

CERTIFICATION:

This is to certify that the construction of Buildings 1, 2, 3, 4, 5, 6, 7, 8, 9, 10, 11, 12, 13, 14, 15, 16, 17, 18, 19, 20, 21, 22, 23, 24, 25, 26 & 27 together with the Clubhouse facility and Maintenance Building, Heritage Deerwood, together with the common elements appurtenant to said buildings, has been completed so that this material together with the provisions of the Declaration describing the condominium property, is an accurate representation of the location and dimensions of the improvements, and that the identification, location and dimensions of the common elements and of each unit referenced above can be determined from these materials.

Sworn to and subscribed before me on this 22nd day of September, 2005, by Richard A. Miller of Richard A. Miller & Associates, Inc., who is personally known to me or has produced his driver's license as identification.

 Notary Public
 My commission Expires 
 Susan M. Hyde
 My Commission DD280211
 Expires March 17, 2008

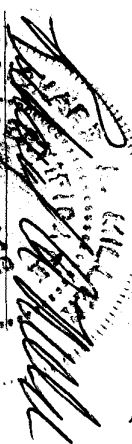
 Richard A. Miller
 Registered Land Surveyor
 State of Florida
 No. 3848
 Dated: 22nd Sept 2005

RICHARD A. MILLER & ASSOCIATES
 PROFESSIONAL LAND SURVEYORS
 6701 BEACH BLVD. SUITE 100
 JACKSONVILLE, FLORIDA 32225
 (904) 721-5758 (FAX)
 (904) 721-1226 (TEL)

LEGEND	
□	DENOTES CONCRETE MONUMENT
X-X	DENOTES FENCE
○	DENOTES 1/2 IRON PIPE SET WITH CAP, R. MILLER & ASSOC. (AS NOTED)
●	DENOTES IRON PIPE FOUND (AS NOTED)

ABBREVIATION	DEFINITION
P.C.P.	Permanent Control Point
P.R.M.	Permanent Reference Monument
R/W	Right of Way
O.R.V.	Official Records Volume
D.B.	Deed Book
Pg.	Page
B.R.L.	Building Restriction Line
Esmt	Easement
L.B.	Licensed Business
R.L.S.	Registered Land Surveyor
J.A.	Jacksonville Electric Authority
EDU	Equipment
A/C	Air Conditioner
C.A.T.V.	Cable Television
O.H.L.	Overhead Lines
(F.M.)	Field Measured
(D)	Deed Measurement
S.A.W.	Sanitary
W.P.	Wood Power Pole
M.H.	Manhole
W.V.	Water Valve
C.L.	Chain Link
U.G.	Underground
TELE.	Telephone
ELEC.	Electrical
CATV	Cable Television
I.P.	Iron Pipe
CONC.	Concrete
CONC.	Concrete Paving
①	NUMBER OF PARKING SPACES
⊛	FIBERGLASS LIGHT POLE
⊙	WATER METER
⊖	WATER VALVE
⊕	SANITARY SEWER MANHOLE
⊗	DRAINAGE INLET
⊘	SPRINKLER CONTRL. VALVE
⊙	TELEPHONE RISER BOX
⊙	CABLE TV RISER BOX
⊙	ELECTRICAL VALVE
⊙	FIRE HYDRANT
⊙	ELECTRICAL MANHOLE
⊙	BACKFLOW PREVENTER
⊙	SANITARY CLEANOUT
⊙	ELECTRICAL TRANSFORMER PAD
⊙	BRICK COLUMN
⊙	MES - WATERED END SECTION
⊙	I.R. - IRON ROD

EXHIBIT "B" HERITAGE DEERWOOD, A CONDOMINIUM

LAND & UTILTY EASEMENT
RECORDS SECTION
RECORDS BOOK 3344
PAGE 1414

FND. I.R.
#3824

N 00°08'34" W 355.65'
60' DRAINAGE EASEMENT
S 00°08'34" E 389.42'

836.00

N 00°08'34" W
468.52' TO CENTERLINE OF
20' JEA WATERLINE EASEMENT

POINT OF BEGINNING
60' DRAINAGE EASEMENT

N 89°51'26" E 1146.00'

POINT OF BEGINNING

OVERALL BOUNDARY &
40' JEA SEWER EASEMENT, POINT OF
REFERENCE 60' DRAINAGE EASEMENT
INTERSECTION OF THE
NORTHERLY EXTENSION
OF THE CENTERLINE
OF ROYAL CREST DRIVE
WITH THE NORTHERLY
LINE OF BURNT MILL ROAD

468.27' TO CENTERLINE OF
20' JEA WATERLINE EASEMENT
836.00

S 00°08'34" E
836.00

SET 1/2" I.P.
MILLER

POINT OF TERMINATION
EXTENSION OF EASEMENT

NORTHERLY RIGHT OF WAY LINE

BURNT MILL ROAD

ROYAL CREST DRIVE
(A 100' RIGHT OF WAY)

JAMES ISLAND UNIT ONE
Plat Book 55, Pages 65, 65A-65H

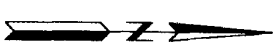
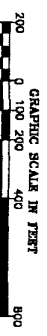

10' JEA ELECTRIC EASEMENT No. 3
OFFICIAL RECORDS BOOK 9440, PAGE 1718

RICHARD A. MILLER & ASSOCIATES
PROFESSIONAL LAND SURVEYORS
6701 BEACH BLVD., SUITE 100
JACKSONVILLE, FLORIDA 32225
(904) 721-5758 (FAX)
(904) 721-1226 (TEL)

JAMES ISLAND UNIT ONE
Plat Book 55, Pages 65, 65A-65H

ROYAL CREST DRIVE
(A 100' RIGHT OF WAY)
Plat Book 52, Pages 65, 65A-65H

JAMES ISLAND UNIT ONE
Plat Book 55, Pages 55, 55A-55K

JAMES ISLAND UNIT ONE
Plat Book 55, Pages 65, 65A-65H

BOUNDARY SURVEY

AUGUST 25, 2005

SHEET 2 OF 86

EXHIBIT "B" HERITAGE DEERWOOD, A CONDOMINIUM

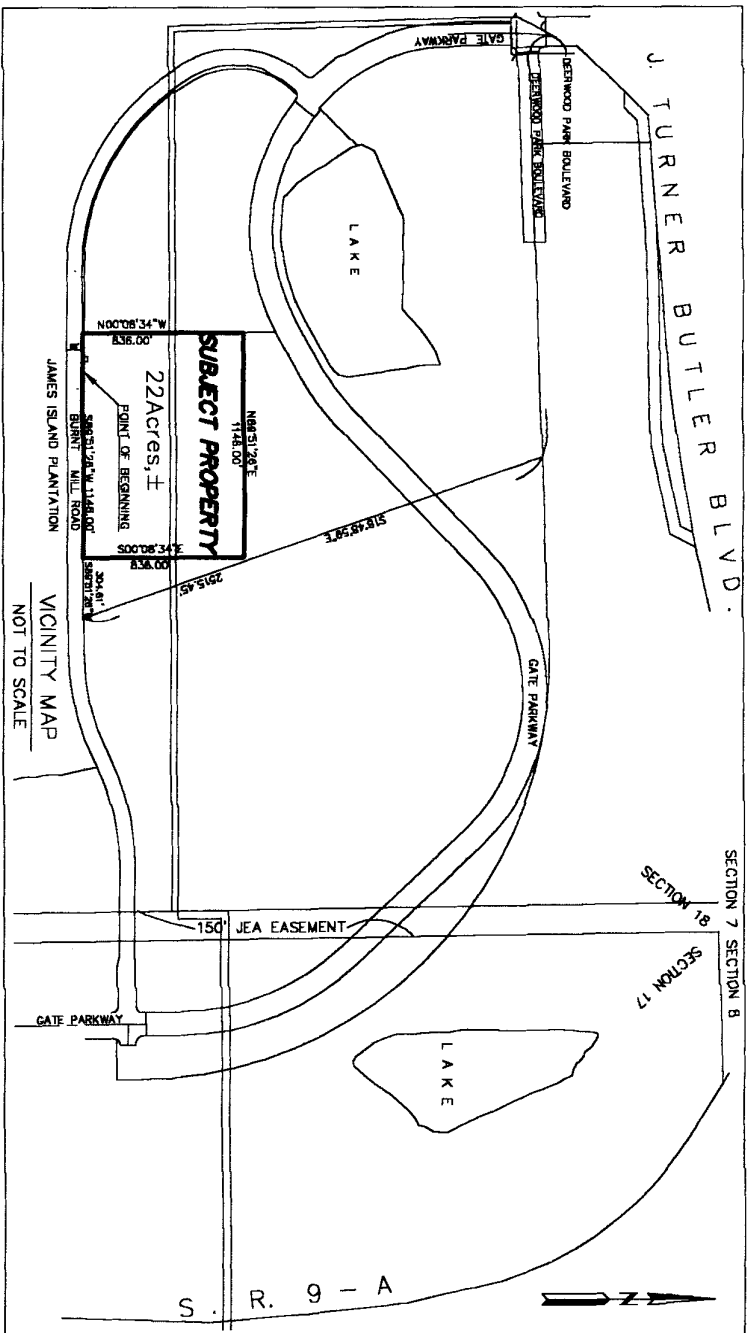

OVERALL BOUNDARY

A portion of Section 18, Township 3 South, Range 28 East, Jacksonville, Duval County, Florida, being more particularly described as follows: For a Point of Beginning, COMMENCE at the point of intersection of the Northerly Extension of the centerline of Royal Crest Drive, a 100 foot right of way according to plat of James Island Unit One as recorded in the Current Public Records of Jacksonville, Duval County, Florida in Plat Book 52, Pages 65, 65A through 65H, inclusive, with the Northerly right of way line of Burnt Mill Road, a variable width right of way according to plat of Gate Parkway Extension as recorded in said Public Records in Plat Book 52, Pages 55, 55A through 55K, inclusive, and run South 89°51'26" West, along said Northerly right of way line, a distance of 214.54 feet to a point; thence departing said Northerly right of way line, run North 00°08'34" West, a distance of 836.00 feet to a point; run thence North 89°51'26" East a distance of 1,146.00 feet to a point; run thence South 00°08'34" East a distance of 836.00 feet to a point in the aforementioned Northerly right of way line of Burnt Mill Road; run thence South 89°51'26" West, a distance of 931.46 feet to the POINT OF BEGINNING.

The lands thus described contains 21.994 acres, more or less.

RICHARD A. MILLER & ASSOCIATES
 PROFESSIONAL LAND SURVEYORS
 6701 BEACH BLVD, SUITE 100
 JACKSONVILLE, FLORIDA 32225
 (904) 721-5758 (FAX)
 (904) 721-1226 (TEL)

LEGAL DESCRIPTION AND VICINITY MAP

AUGUST 25, 2005

SHEET 3 OF 86

EXHIBIT "B" HERITAGE DEERWOOD, A CONDOMINIUM

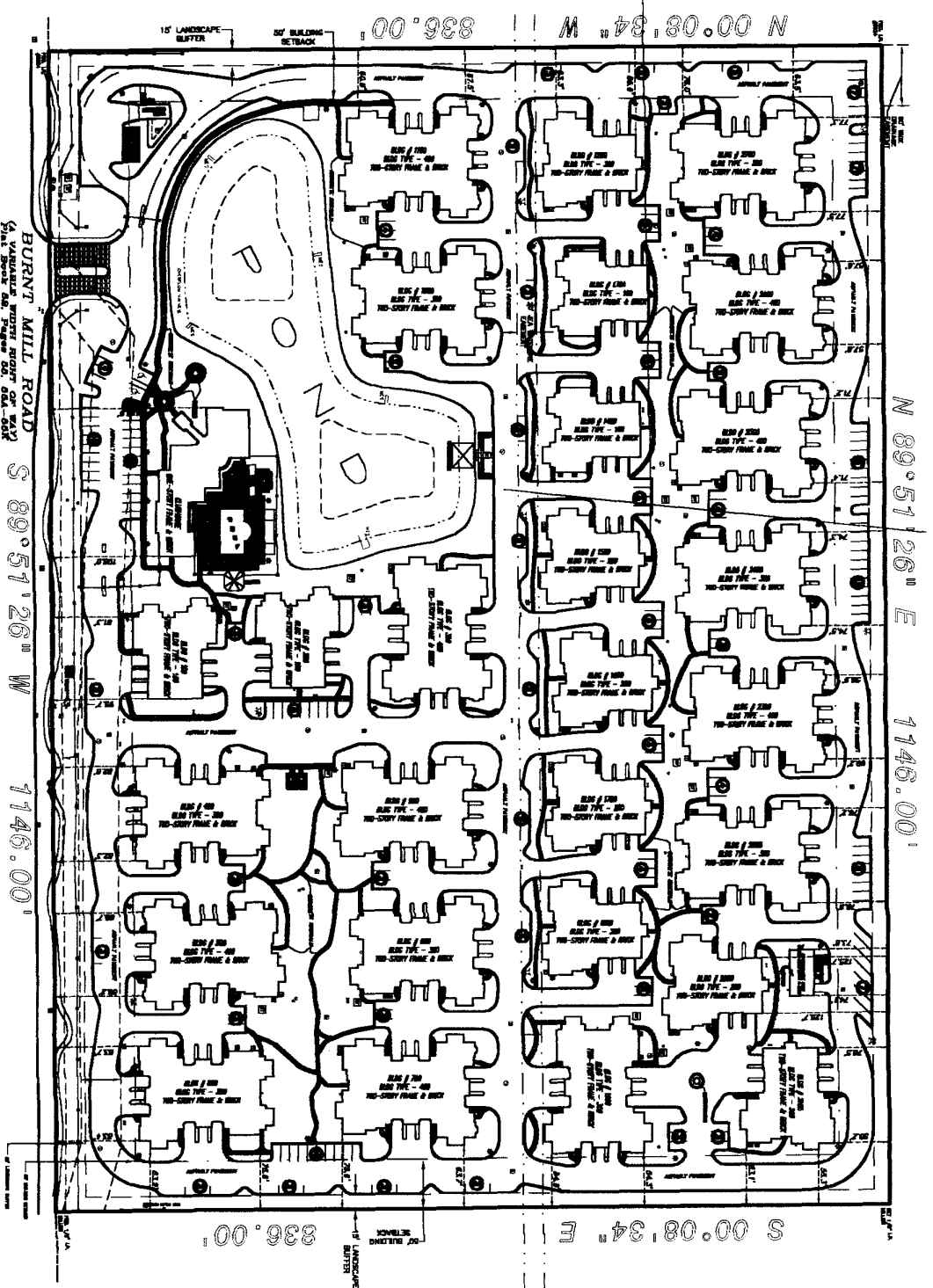

CONDOMINIUM PLOT PLAN

RICHARD A. MILLER & ASSOCIATES
 PROFESSIONAL LAND SURVEYORS
 6701 BEACH BLVD, SUITE 100
 JACKSONVILLE, FLORIDA 32225
 (904) 721-5758 (FAX)
 (904) 721-1226 (TEL)

AUGUST 25, 2005

SHEET: 4 OF 86



TOTAL LAND USE: 51,844 ACRES
 TOTAL PARKING SPACES: 458
 HANDICAP SPACES: 2
 STANDARD SPACES: 427

COMMON ELEMENT
 CE-COMMON ELEMENT

EXHIBIT "B" HERITAGE DEERWOOD, A CONDOMINIUM

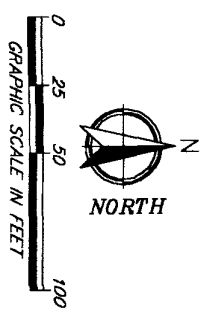

SHEET 2

FND. I.R.
#3624

60' WIDE
DRAINAGE
EASEMENT

N 89° 51' 26" E 1146.00'

N 00° 08' 34" W 836.00'

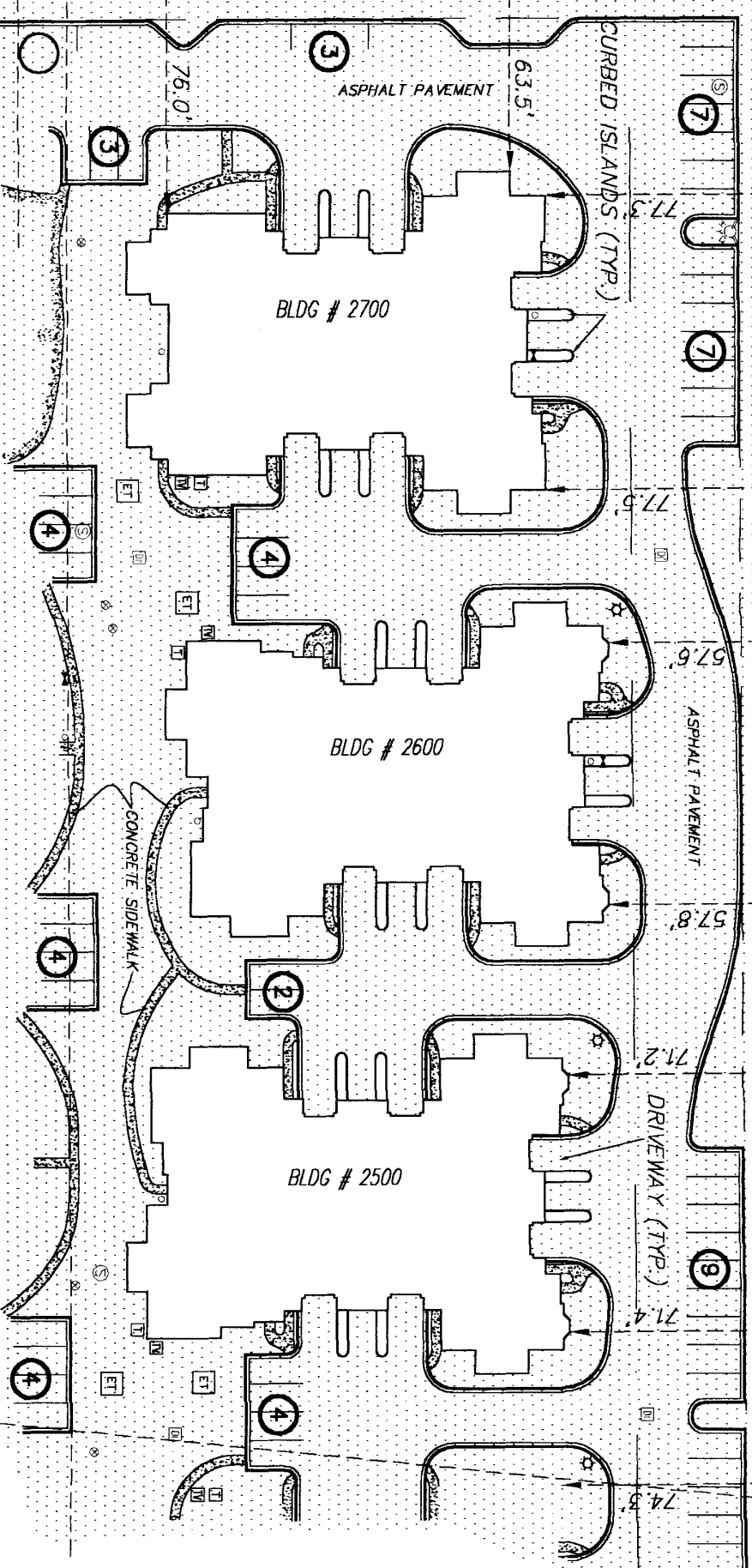

C.E. = COMMON ELEMENTS

ALL DRIVEWAYS & CURBED ISLANDS
ARE LIMITED COMMON ELEMENTS

SHEET 5

RICHARD A. MILLER & ASSOCIATES
 PROFESSIONAL LAND SURVEYORS
 6701 BEACH BLVD. SUITE 100
 JACKSONVILLE, FLORIDA 32225
 (904) 721-5758 (FAX)
 (904) 721-1226 (TEL)

CONDOMINIUM PLOT PLAN SHEET 1

AUGUST 25, 2005

SHEET: 5 OF 86

EXHIBIT "B" HERITAGE DEERWOOD, A CONDOMINIUM

ALL DRIVEWAYS & CURBED ISLANDS
ARE LIMITED COMMON ELEMENTS

COMMON ELEMENT

N 89° 51' 26" E 1746.00'

SHEET 2
SHEET 3

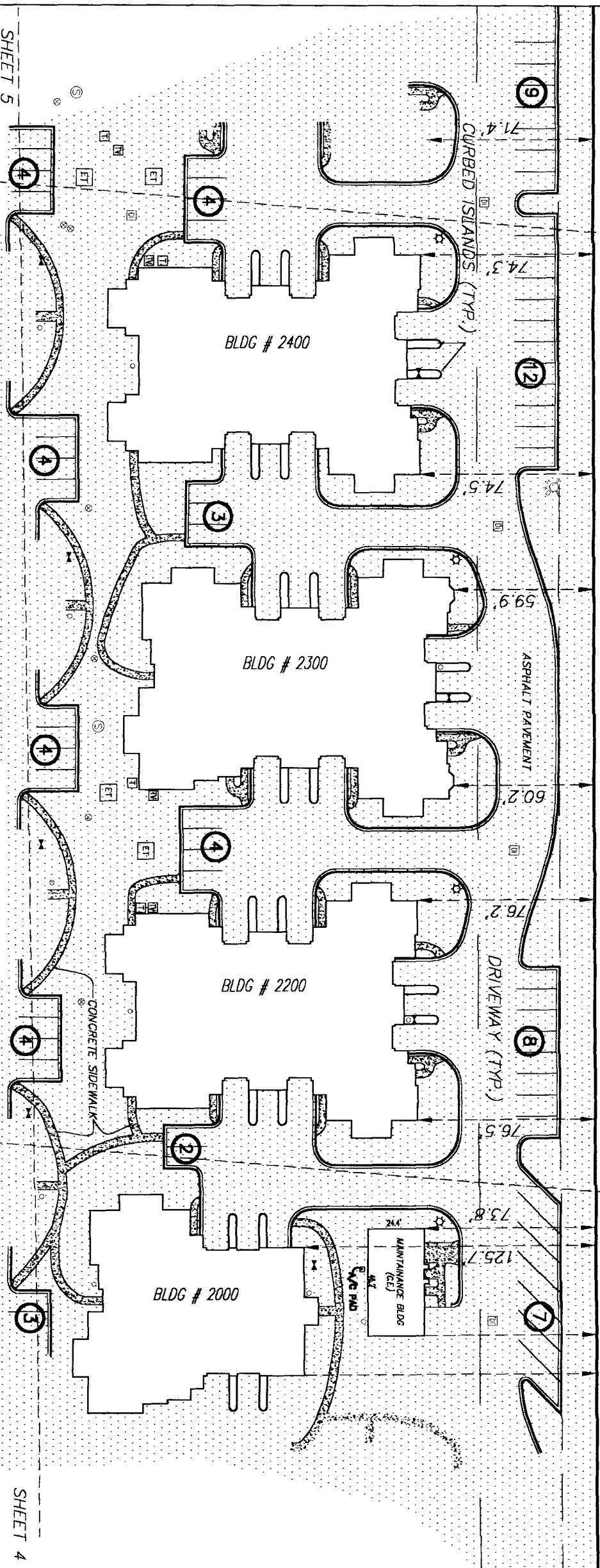
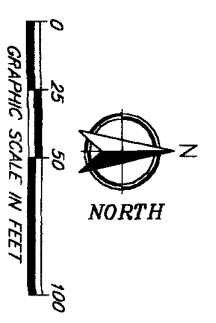

SHEET 5

RICHARD A. MILLER & ASSOCIATES
 PROFESSIONAL LAND SURVEYORS
 6701 BEACH BLVD. SUITE 100
 JACKSONVILLE, FLORIDA 32225
 (904) 721-5758 (FAX)
 (904) 721-1226 (TEL)

C.E. = COMMON ELEMENTS

CONDOMINIUM PLOT PLAN SHEET 2

AUGUST 25, 2005

SHEET: 6 OF 86

SHEET 4

EXHIBIT "B"

HERITAGE DEERWOOD, A CONDOMINIUM

N 89° 51' 26" E 1146.00'

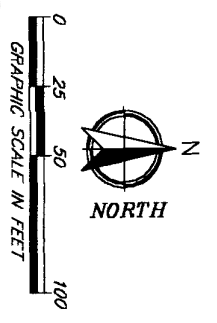
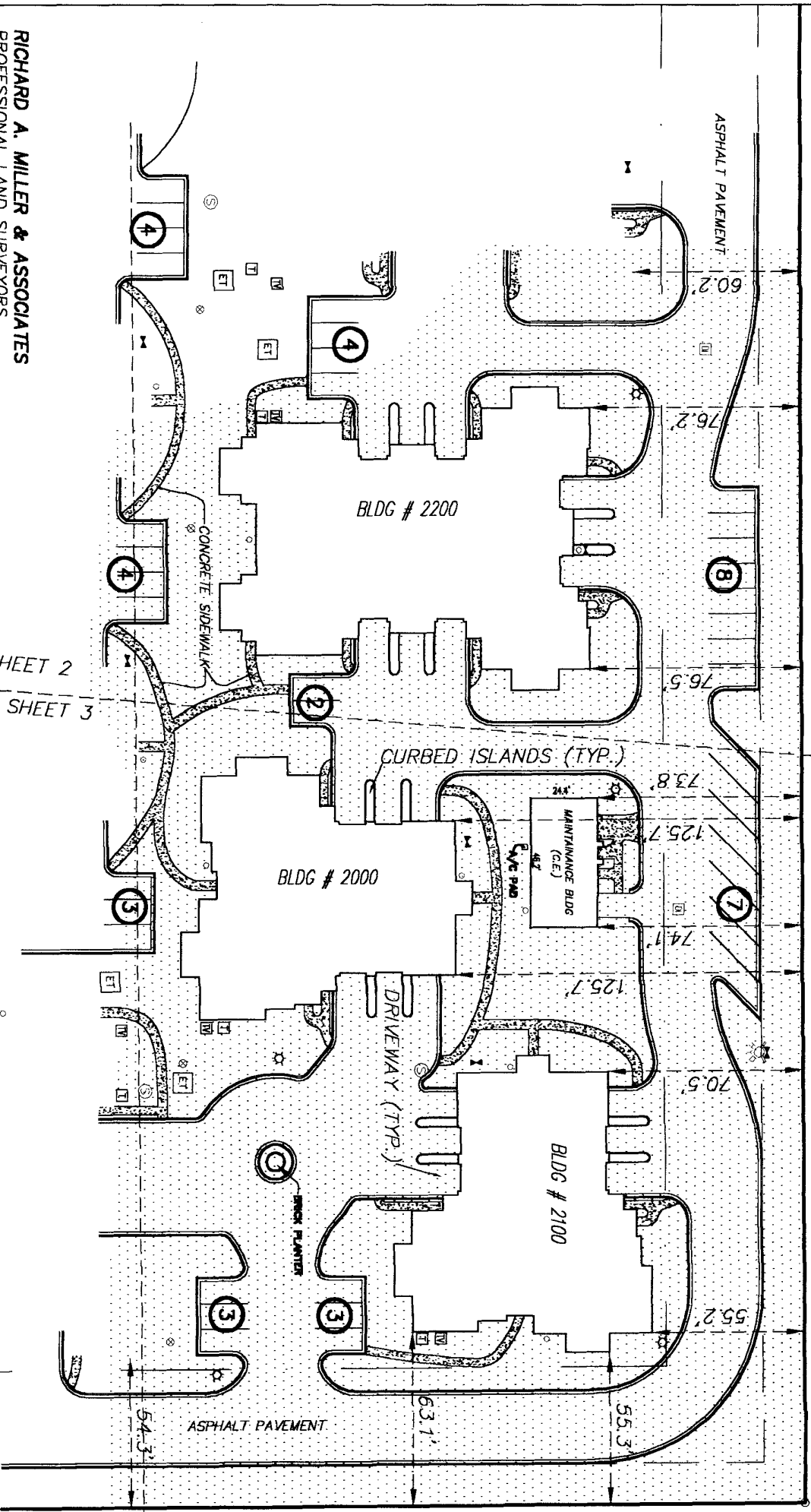

RICHARD A. MILLER & ASSOCIATES
 PROFESSIONAL LAND SURVEYORS
 6701 BEACH BLVD. SUITE 100
 JACKSONVILLE, FLORIDA 32225
 (904) 721-5758 (FAX)
 (904) 721-1226 (TEL)

ALL DRIVEWAYS & CURBED ISLANDS
 ARE LIMITED COMMON ELEMENTS
 C.E.=COMMON ELEMENTS

CONDOMINIUM PLOT PLAN
 SHEET 3

836.00'

S 00° 08' 34" E

TOTAL LAND USE: 21.894± ACRES
 TOTAL PARKING SPACES: 429
 HANDICAP SPACES: 2
 STANDARD SPACES: 427

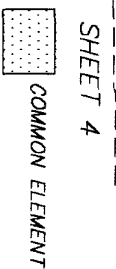

AUGUST 25, 2005

SHEET: 7 OF 86

EXHIBIT "B" HERITAGE DEERWOOD, A CONDOMINIUM

COMMON ELEMENT

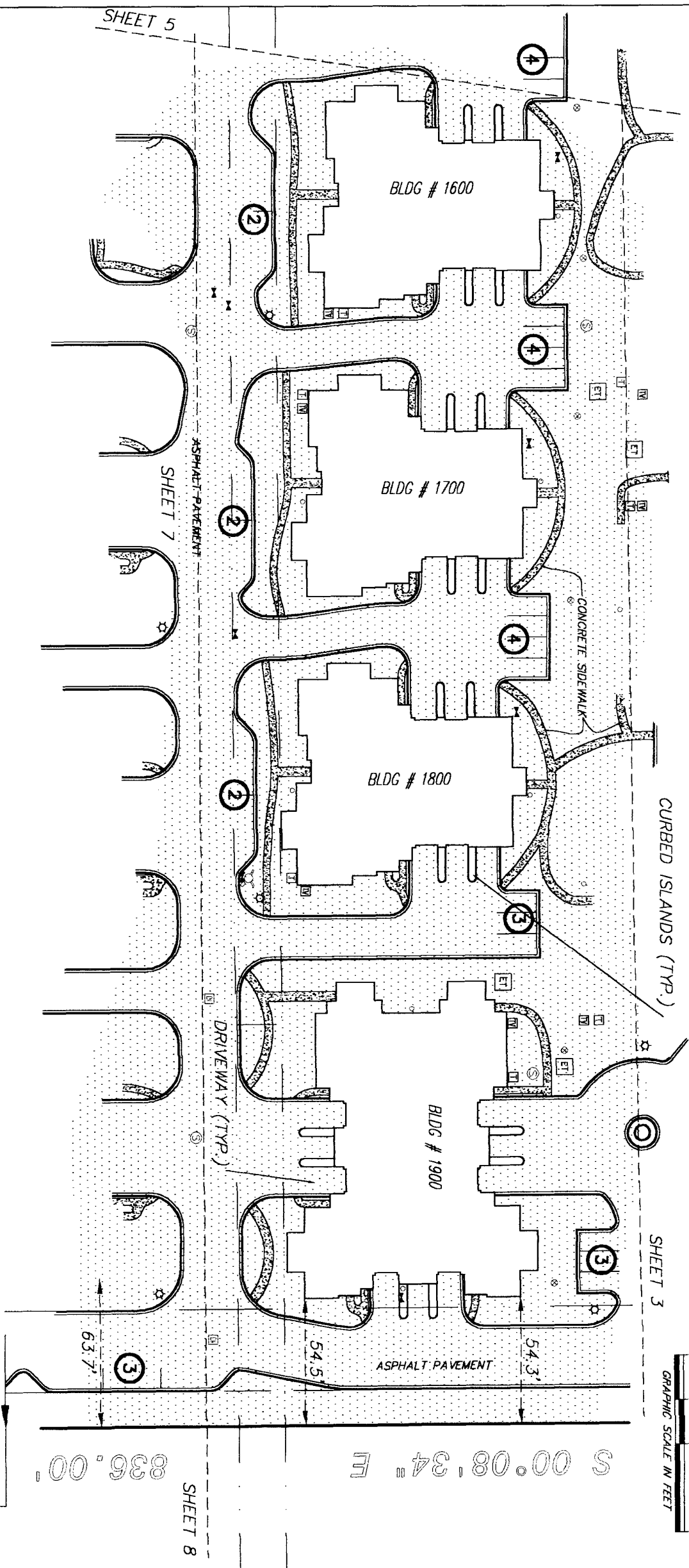

SHEET 5

CURBED ISLANDS (TYP.)

CONCRETE SIDE WALK

ASPHALT PAVEMENT

DRIVEWAY (TYP.)

ASPHALT PAVEMENT

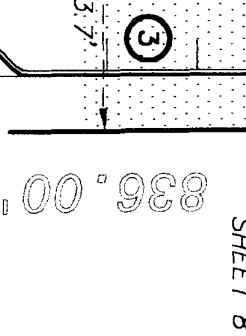
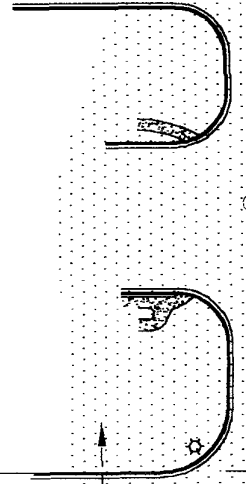
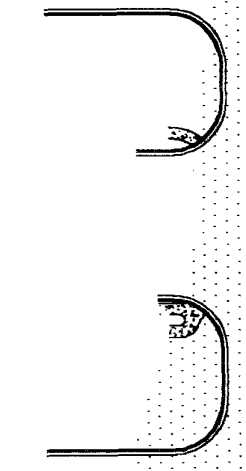
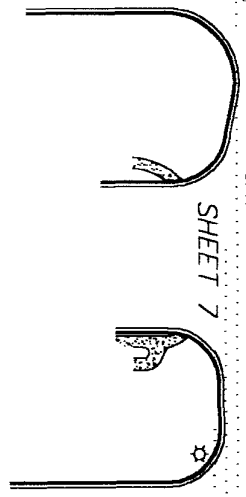
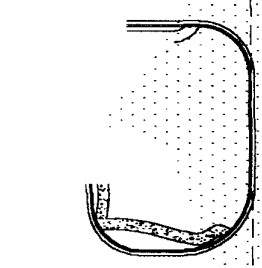

RICHARD A. MILLER & ASSOCIATES
PROFESSIONAL LAND SURVEYORS
6701 BEACH BLVD, SUITE 100
JACKSONVILLE, FLORIDA 32225
(904) 721-5758 (FAX)
(904) 721-1226 (TEL)

ALL DRIVEWAYS & CURBED ISLANDS
ARE LIMITED COMMON ELEMENTS
C.E.=COMMON ELEMENTS

CONDOMINIUM PLOT PLAN

SHEET 4

AUGUST 25, 2005

SHEET: 8 OF 86

SHEET 8

SHEET 3

EXHIBIT "B" HERITAGE DEERWOOD, A CONDOMINIUM

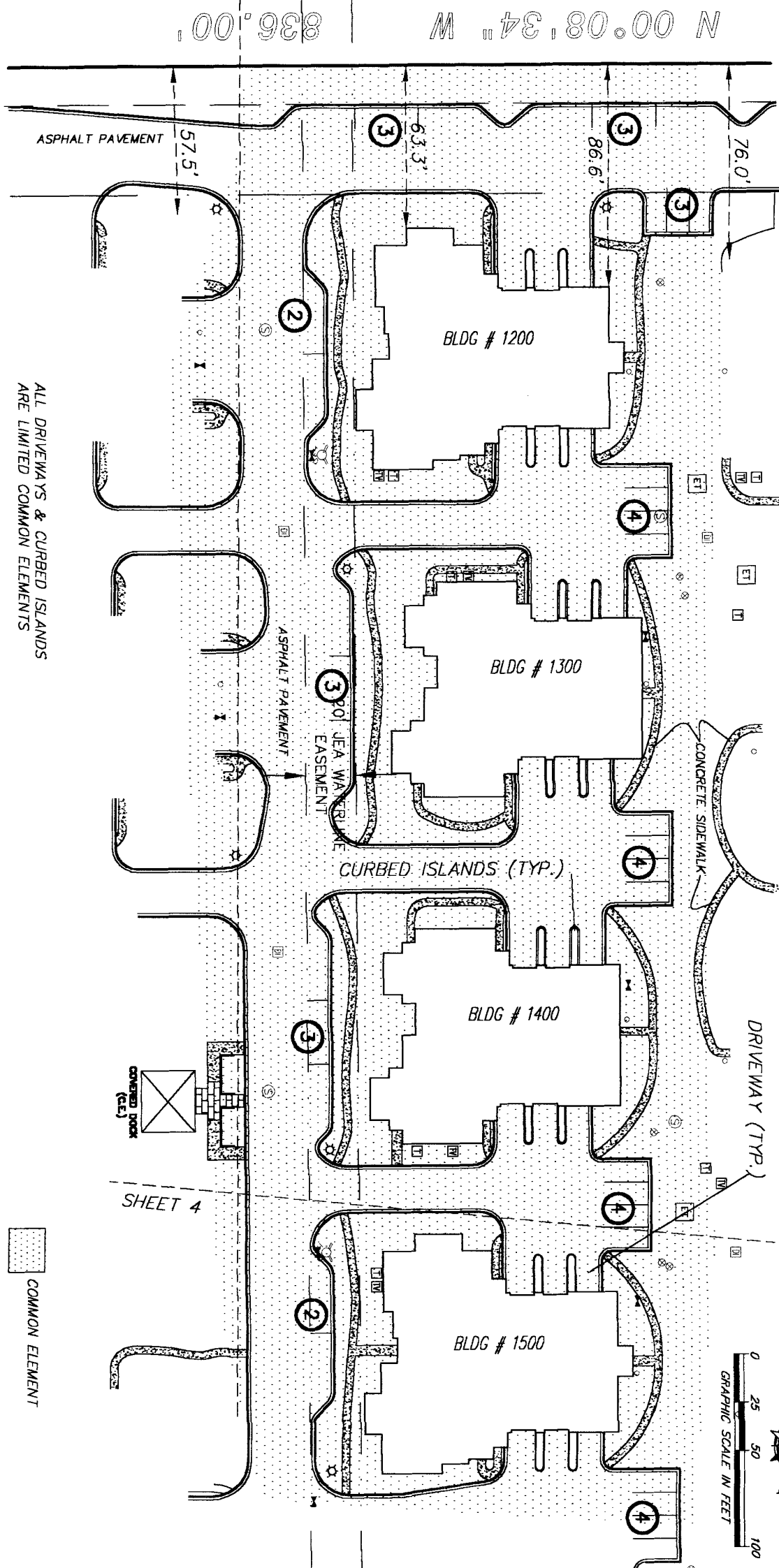

RICHARD A. MILLER & ASSOCIATES
 PROFESSIONAL LAND SURVEYORS
 6701 BEACH BLVD, SUITE 100
 JACKSONVILLE, FLORIDA 32225
 (904) 721-5758 (FAX)
 (904) 721-1226 (TEL)

ALL DRIVEWAYS & CURBED ISLANDS
 ARE LIMITED COMMON ELEMENTS
 C.E.=COMMON ELEMENTS

CONDOMINIUM PLOT PLAN SHEET 5

AUGUST 25, 2005

SHEET: 9 OF 86

EXHIBIT "B" HERITAGE DEERWOOD, A CONDOMINIUM

SHEET 5

SHEET 11

N 00° 08' 34" W 36° 00' 00"

50' BUILDING SETBACK

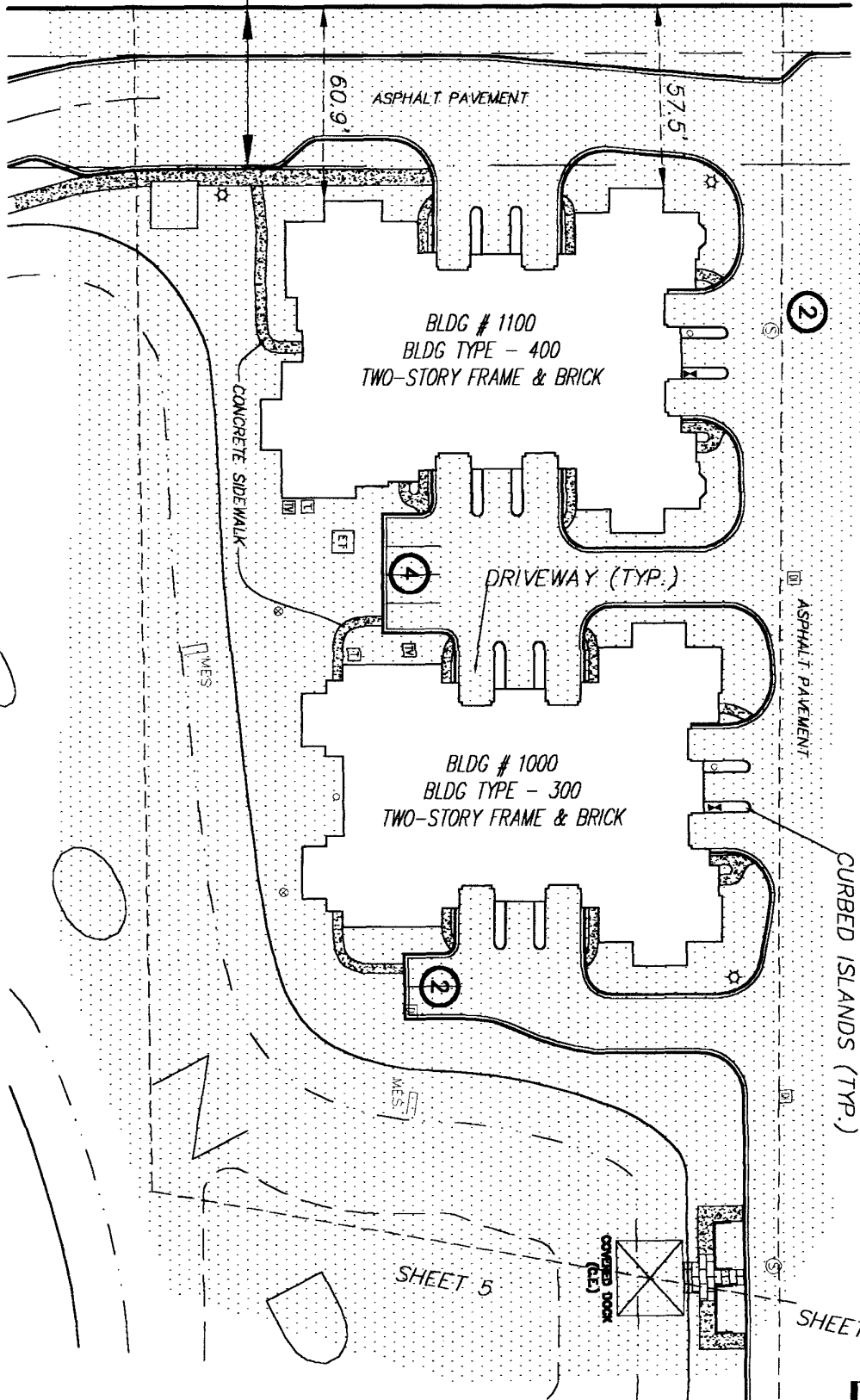

ALL DRIVEWAYS & CURBED ISLANDS
ARE LIMITED COMMON ELEMENTS

C.E. = COMMON ELEMENTS

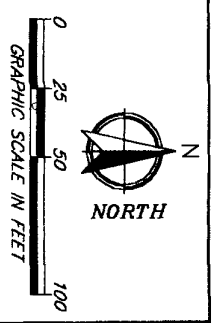
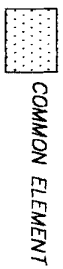

RICHARD A. MILLER & ASSOCIATES
PROFESSIONAL LAND SURVEYORS
6701 BEACH BLVD. SUITE 100
JACKSONVILLE, FLORIDA 32225
(904) 721-5758 (FAX)
(904) 721-1226 (TEL)

CONDOMINIUM PLOT PLAN
SHEET 6

AUGUST 25, 2005

SHEET: 10 OF 86

EXHIBIT "B" HERITAGE DEFERWOOD, A CONDOMINIUM

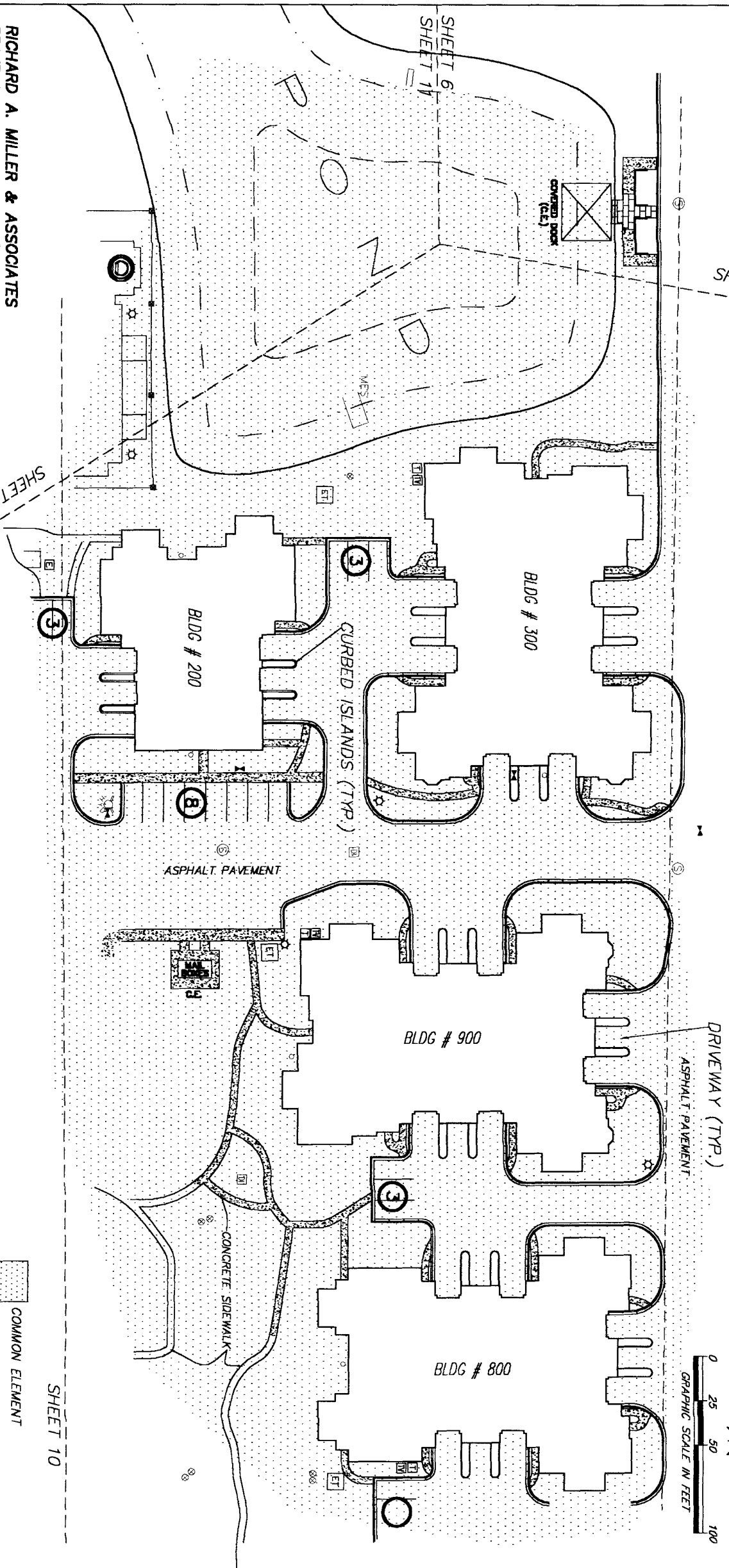

RICHARD A. MILLER & ASSOCIATES
 PROFESSIONAL LAND SURVEYORS
 6701 BEACH BLVD. SUITE 100
 JACKSONVILLE, FLORIDA 32225
 (904) 721-5758 (FAX)
 (904) 721-1226 (TEL)

ALL DRIVEWAYS & CURBED ISLANDS
 ARE LIMITED COMMON ELEMENTS
 C.E. = COMMON ELEMENTS

CONDOMINIUM PLOT PLAN
 SHEET 7

AUGUST 25, 2005

SHEET: 11 OF 86

COMMON ELEMENT

SHEET 10

SHEET 6

SHEET 6
 SHEET 11

0 25 50 100
 GRAPHIC SCALE IN FEET



EXHIBIT "B" HERITAGE DEERWOOD, A CONDOMINIUM

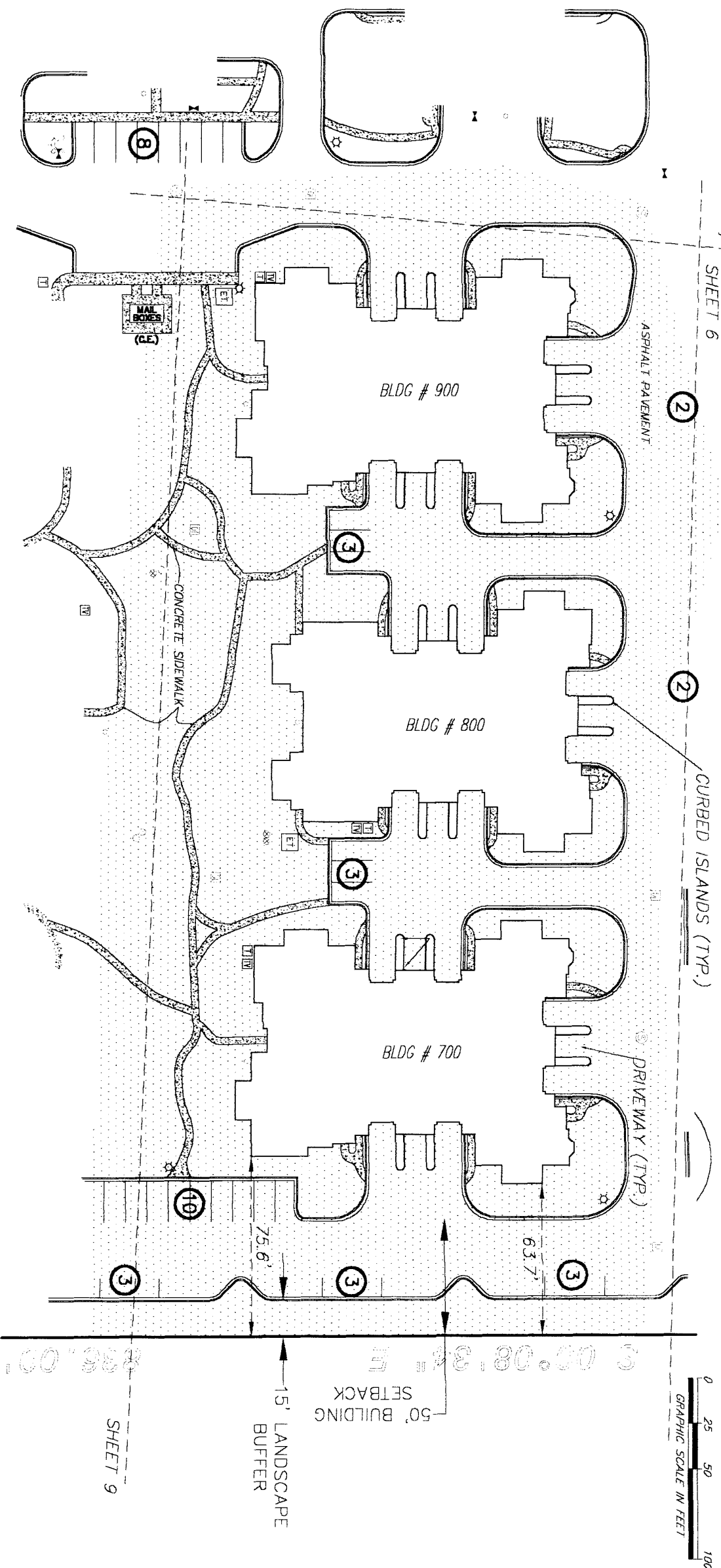

RICHARD A. MILLER & ASSOCIATES
 PROFESSIONAL LAND SURVEYORS
 6701 BEACH BLVD. SUITE 100
 JACKSONVILLE, FLORIDA 32225
 (904) 721-5758 (FAX)
 (904) 721-1226 (TEL)

ALL DRIVEWAYS & CURBED ISLANDS
 ARE LIMITED COMMON ELEMENTS
 C.E.=COMMON ELEMENTS

CONDOMINIUM PLOT PLAN SHEET 8

COMMON ELEMENT

AUGUST 25, 2005

SHEET: 12 OF 86

EXHIBIT "B" HERITAGE DEERWOOD, A CONDOMINIUM

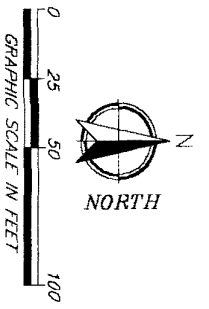
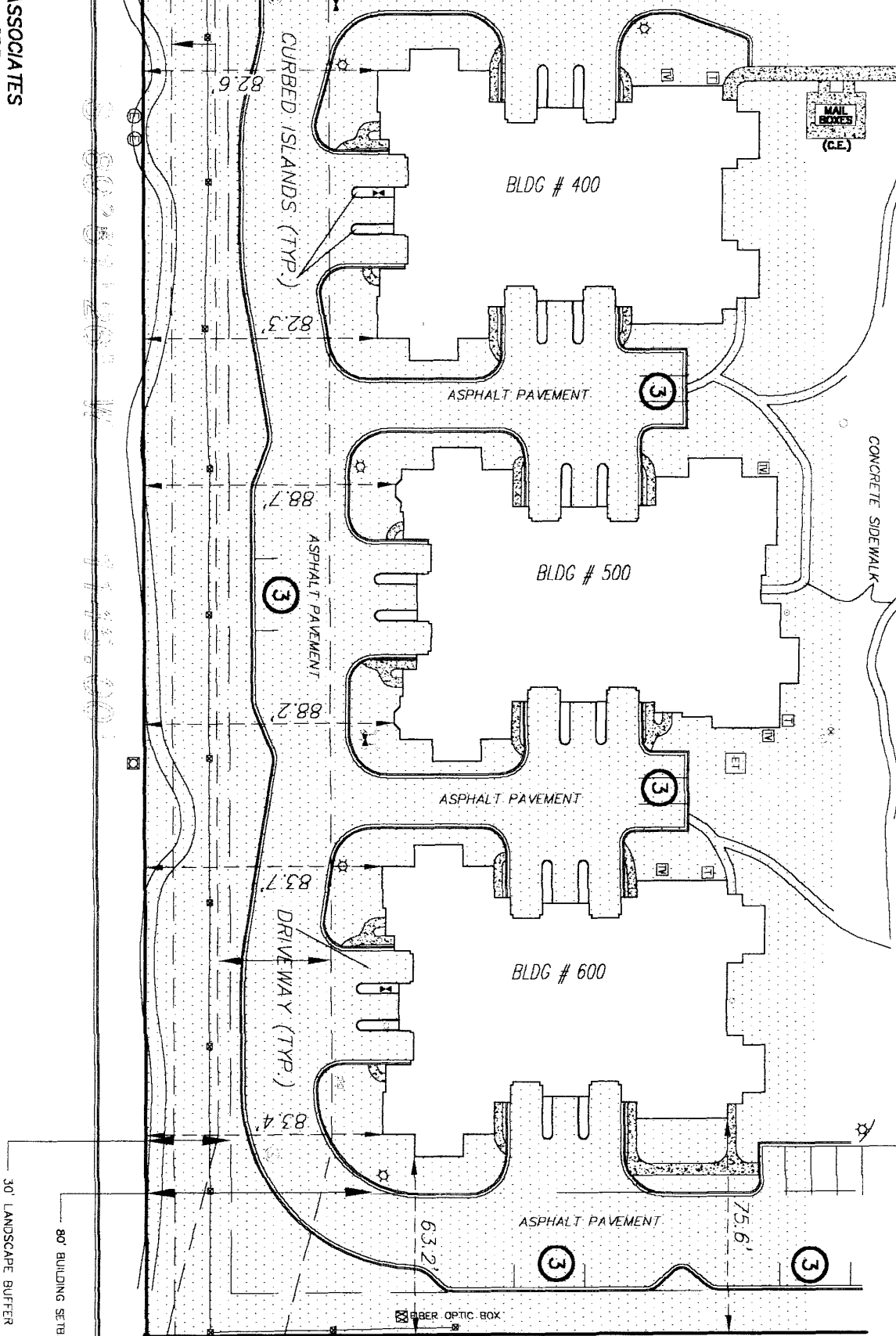

30' LANDSCAPE BUFFER
80' BUILDING SETBACK

COMMON ELEMENT

RICHARD A. MILLER & ASSOCIATES
PROFESSIONAL LAND SURVEYORS
6701 BEACH BLVD, SUITE 100
JACKSONVILLE, FLORIDA 32225
(904) 721-5758 (FAX)
(904) 721-1226 (TEL)

ALL DRIVEWAYS & CURBED ISLANDS
ARE LIMITED COMMON ELEMENTS
C.E.=COMMON ELEMENTS

CONDOMINIUM PLOT PLAN
SHEET 9

AUGUST 25, 2005

SHEET: 13 OF 86

END 1/2" I.P.
MILLER

EXHIBIT "B" HERITAGE DEFERWOOD, A CONDOMINIUM

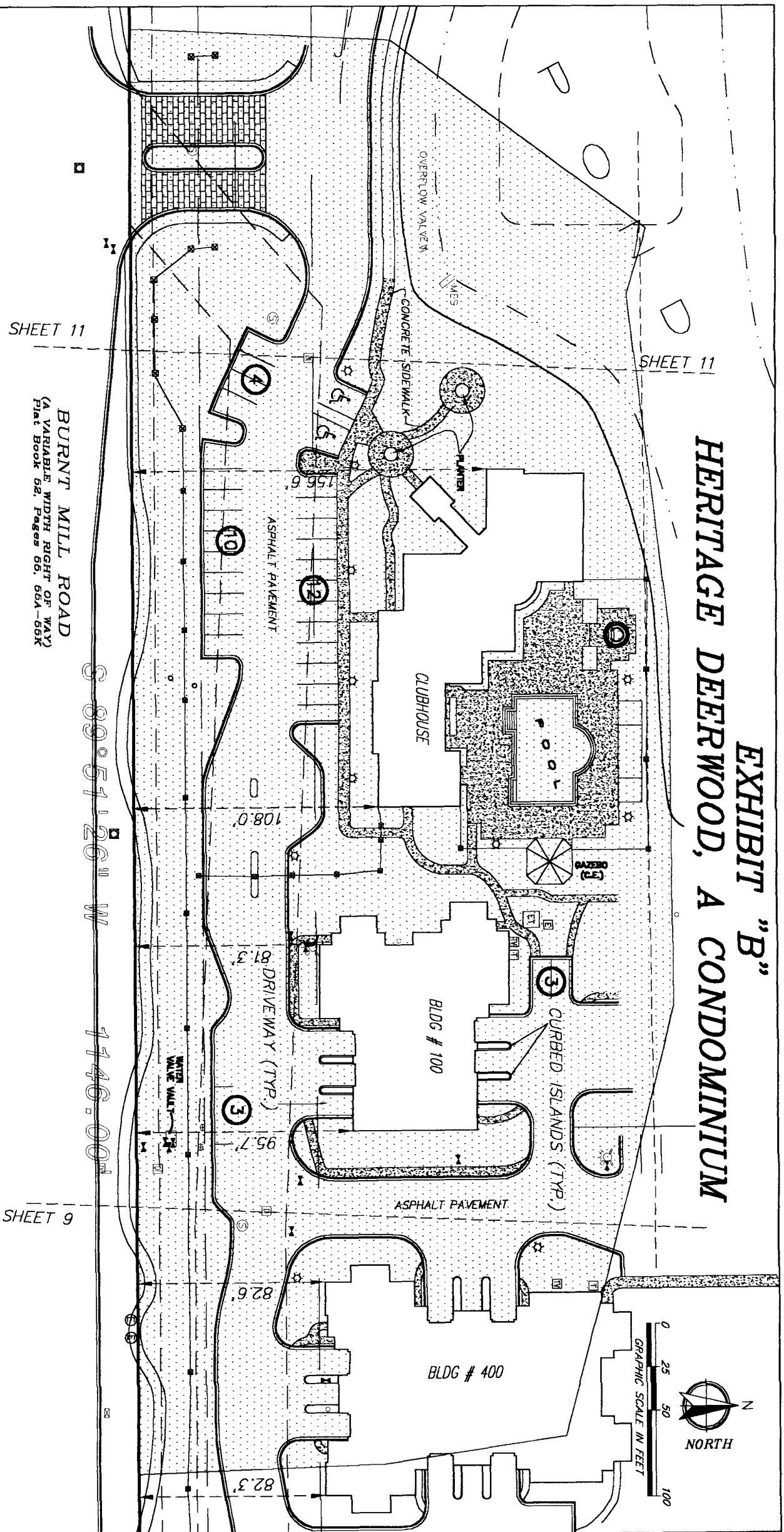

SHEET 11

BURNT MILL ROAD
(A VARIABLE WIDTH RIGHT OF WAY)
Plat Book 62, Pages 65, 65A-65K

SHEET 9

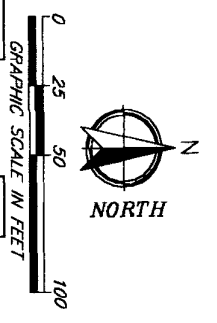

RICHARD A. MILLER & ASSOCIATES
PROFESSIONAL LAND SURVEYORS
6701 BEACH BLVD., SUITE 100
JACKSONVILLE, FLORIDA 32225
(904) 721-5758 (FAX)
(904) 721-1226 (TEL)

ALL DRIVEWAYS & CURBED ISLANDS
ARE LIMITED COMMON ELEMENTS
C.E.=COMMON ELEMENTS

CONDOMINIUM PLOT PLAN
SHEET 10

AUGUST 25, 2005

SHEET: 14 OF 86

EXHIBIT "B" HERITAGE DEERWOOD, A CONDOMINIUM

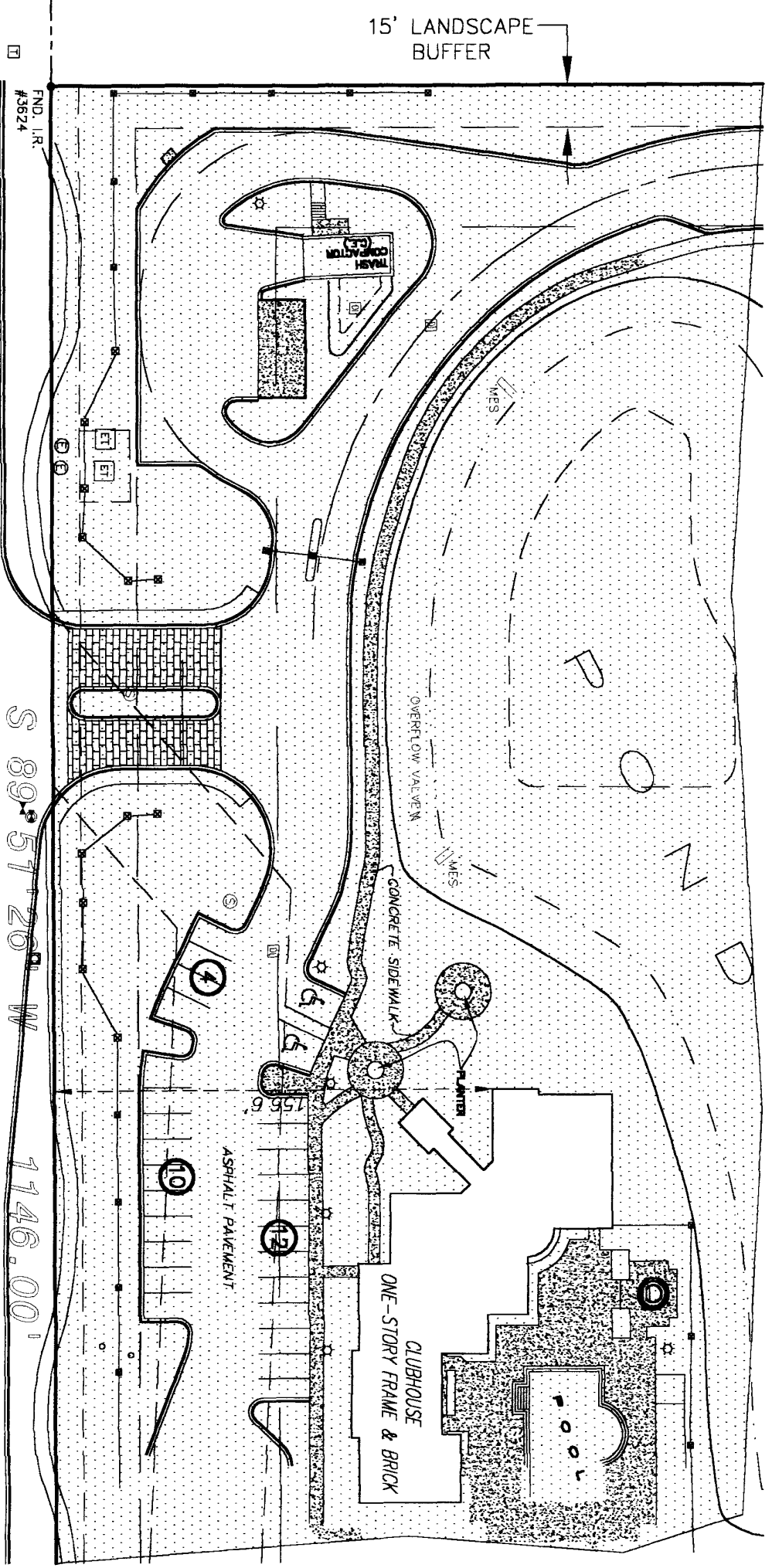

RICHARD A. MILLER & ASSOCIATES
 PROFESSIONAL LAND SURVEYORS
 6701 BEACH BLVD. SUITE 100
 JACKSONVILLE, FLORIDA 32225
 (904) 721-5758 (FAX)
 (904) 721-1226 (TEL)

ALL DRIVEWAYS & CURBED ISLANDS
 ARE LIMITED COMMON ELEMENTS

BURNT MILL ROAD
 (A VARIABLE WIDTH RIGHT OF WAY)
 Plat Book 62, Pages 65, 66A-66K

CONDOMINIUM PLOT PLAN
SHEET 11

AUGUST 25, 2005

COMMON ELEMENT

SHEET: 15 OF 86

EXHIBIT "B" HERITAGE DEERWOOD, A CONDOMINIUM

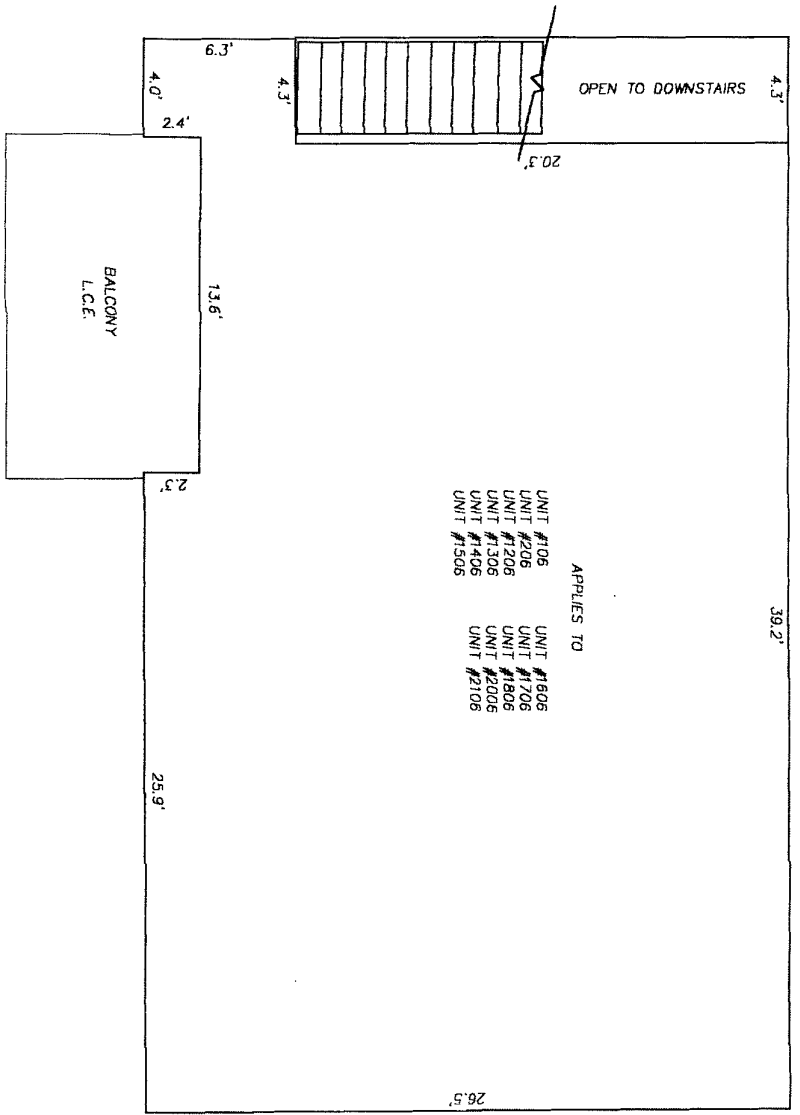
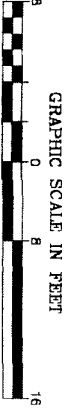

UNIT TYPE A1 PLOT PLAN

RICHARD A. MILLER & ASSOCIATES
 PROFESSIONAL LAND SURVEYORS
 6701 BEACH BLVD. SUITE 100
 JACKSONVILLE, FLORIDA 32225
 (904) 721-5758 (FAX)
 (904) 721-1226 (TEL)

AUGUST 25, 2005

SHEET: 16 OF 86



EXHIBIT "B" HERITAGE DEERWOOD, A CONDOMINIUM

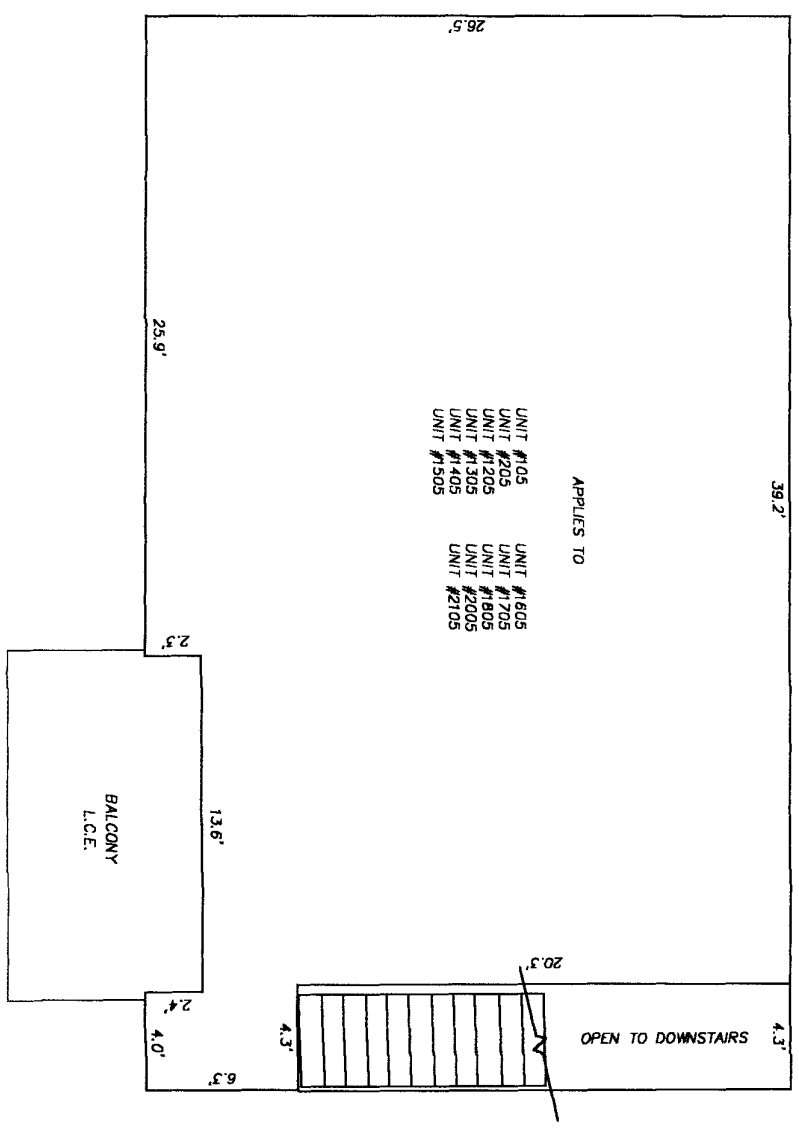

UNIT TYPE A1-REVERSE PLOT PLAN

RICHARD A. MILLER & ASSOCIATES
 PROFESSIONAL LAND SURVEYORS
 6701 BEACH BLVD, SUITE 100
 JACKSONVILLE, FLORIDA 32225
 (904) 721-5758 (FAX)
 (904) 721-1226 (TEL)

AUGUST 25, 2005

SHEET: 17 OF 86



EXHIBIT "B" HERITAGE DEERWOOD, A CONDOMINIUM

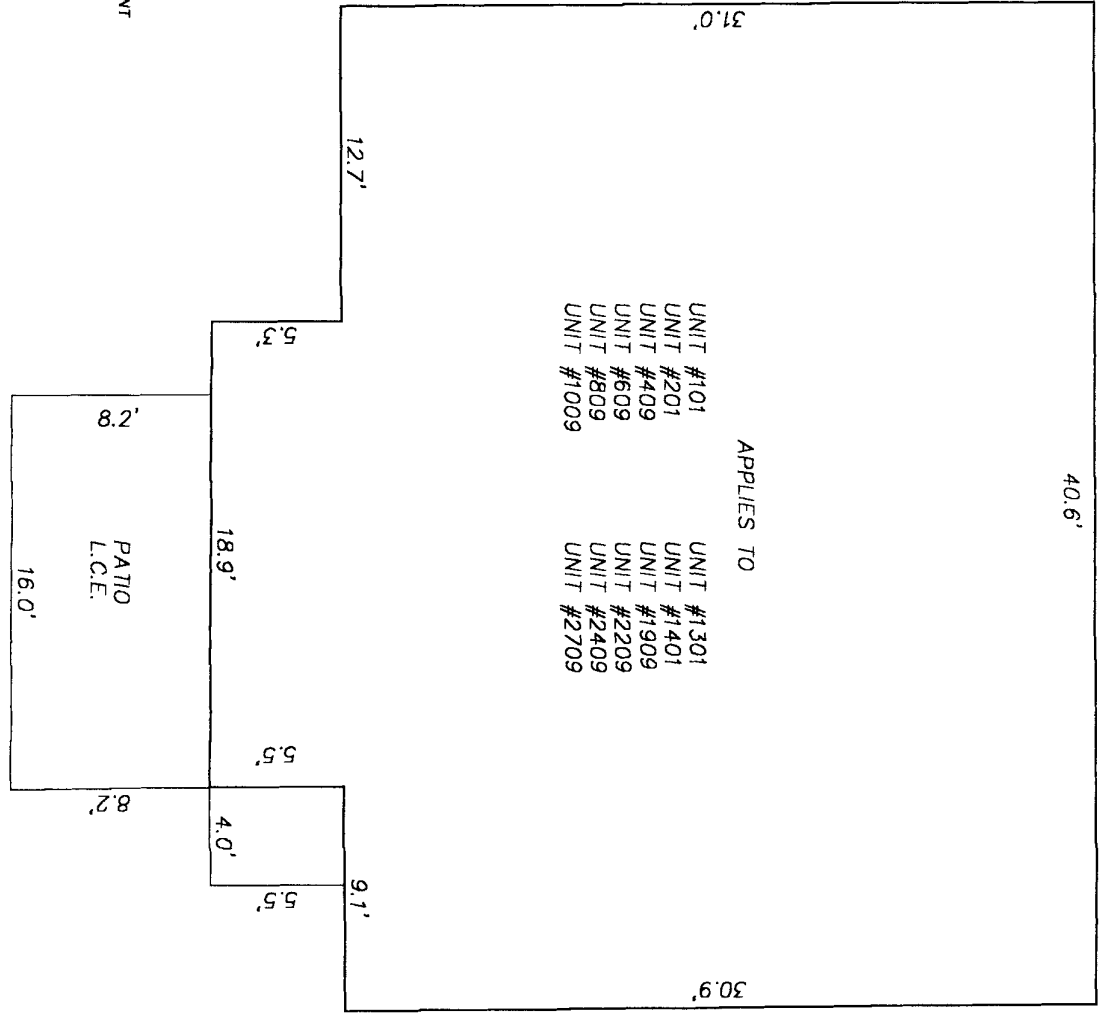

L.C.E.=LIMITED COMMON ELEMENT

RICHARD A. MILLER & ASSOCIATES
 PROFESSIONAL LAND SURVEYORS
 6701 BEACH BLVD. SUITE 100
 JACKSONVILLE, FLORIDA 32225
 (904) 721-5758 (FAX)
 (904) 721-1226 (TEL)

UNIT TYPE B1A PLOT PLAN

AUGUST 25, 2005

SHEET: 18 OF 86

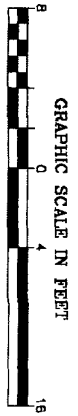
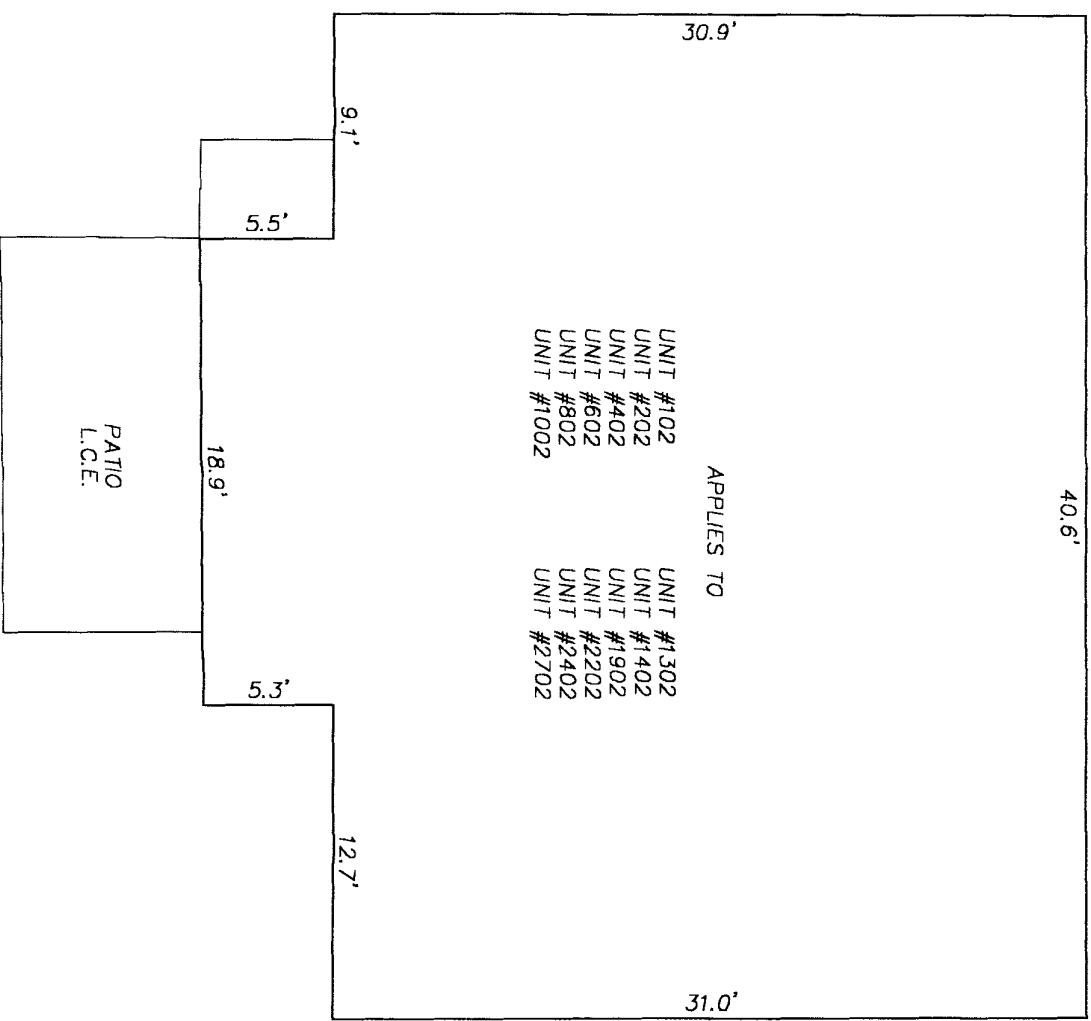

EXHIBIT "B" HERITAGE DEERWOOD, A CONDOMINIUM



APPLIES TO

UNIT #102	UNIT #1302
UNIT #202	UNIT #1402
UNIT #402	UNIT #1902
UNIT #602	UNIT #2202
UNIT #802	UNIT #2402
UNIT #1002	UNIT #2702

RICHARD A. MILLER & ASSOCIATES
 PROFESSIONAL LAND SURVEYORS
 6701 BEACH BLVD. SUITE 100
 JACKSONVILLE, FLORIDA 32225
 (904) 721-5758 (FAX)
 (904) 721-1226 (TEL)

UNIT TYPE B1A REVERSE PLOT PLAN

AUGUST 25, 2005

SHEET: 19 OF 86



EXHIBIT "B" HERITAGE DEERWOOD, A CONDOMINIUM

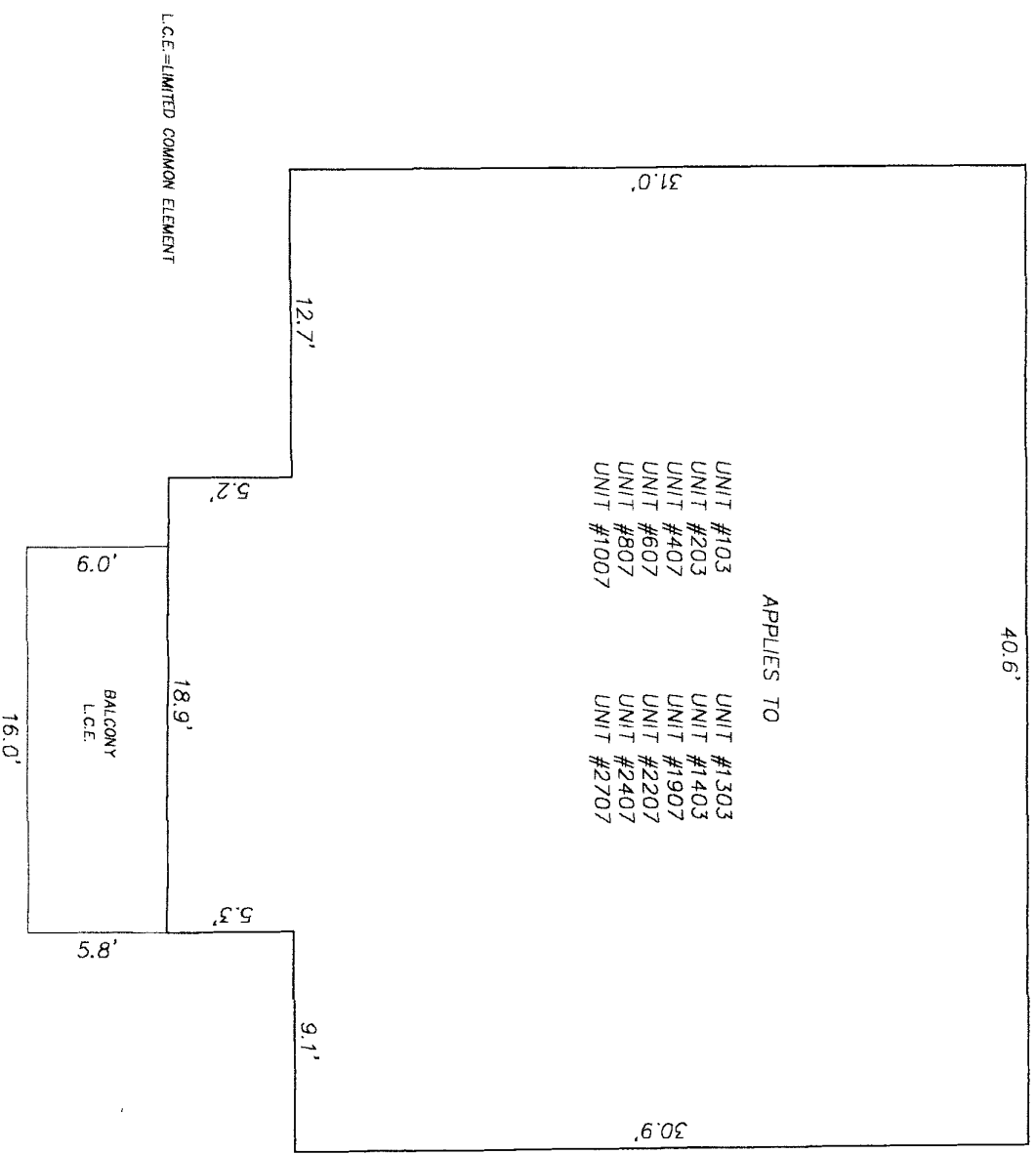

UNIT TYPE B1B PLOT PLAN

RICHARD A. MILLER & ASSOCIATES
 PROFESSIONAL LAND SURVEYORS
 6701 BEACH BLVD. SUITE 100
 JACKSONVILLE, FLORIDA 32225
 (904) 721-5758 (FAX)
 (904) 721-1226 (TEL)

AUGUST 25, 2005

SHEET: 20 OF 86

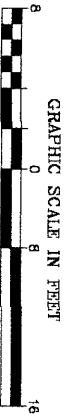
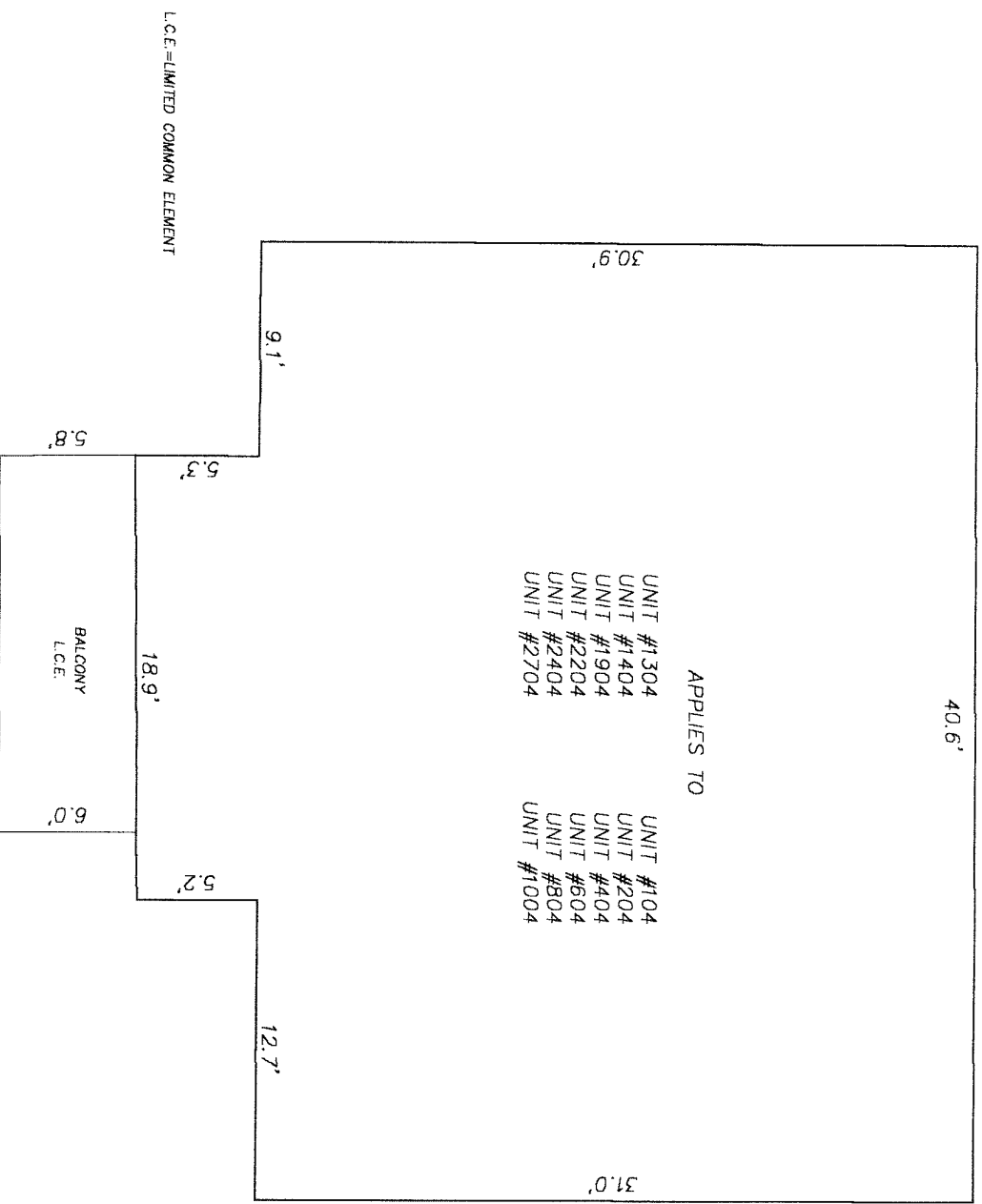

EXHIBIT "B" HERITAGE DEERWOOD, A CONDOMINIUM



UNIT TYPE B1B REVERSE PLOT PLAN

RICHARD A. MILLER & ASSOCIATES
 PROFESSIONAL LAND SURVEYORS
 6701 BEACH BLVD. SUITE 100
 JACKSONVILLE, FLORIDA 32225
 (904) 721-5758 (FAX)
 (904) 721-1226 (TEL)

AUGUST 25, 2005

SHEET: 21 OF 86

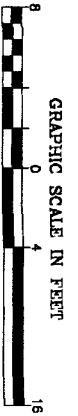
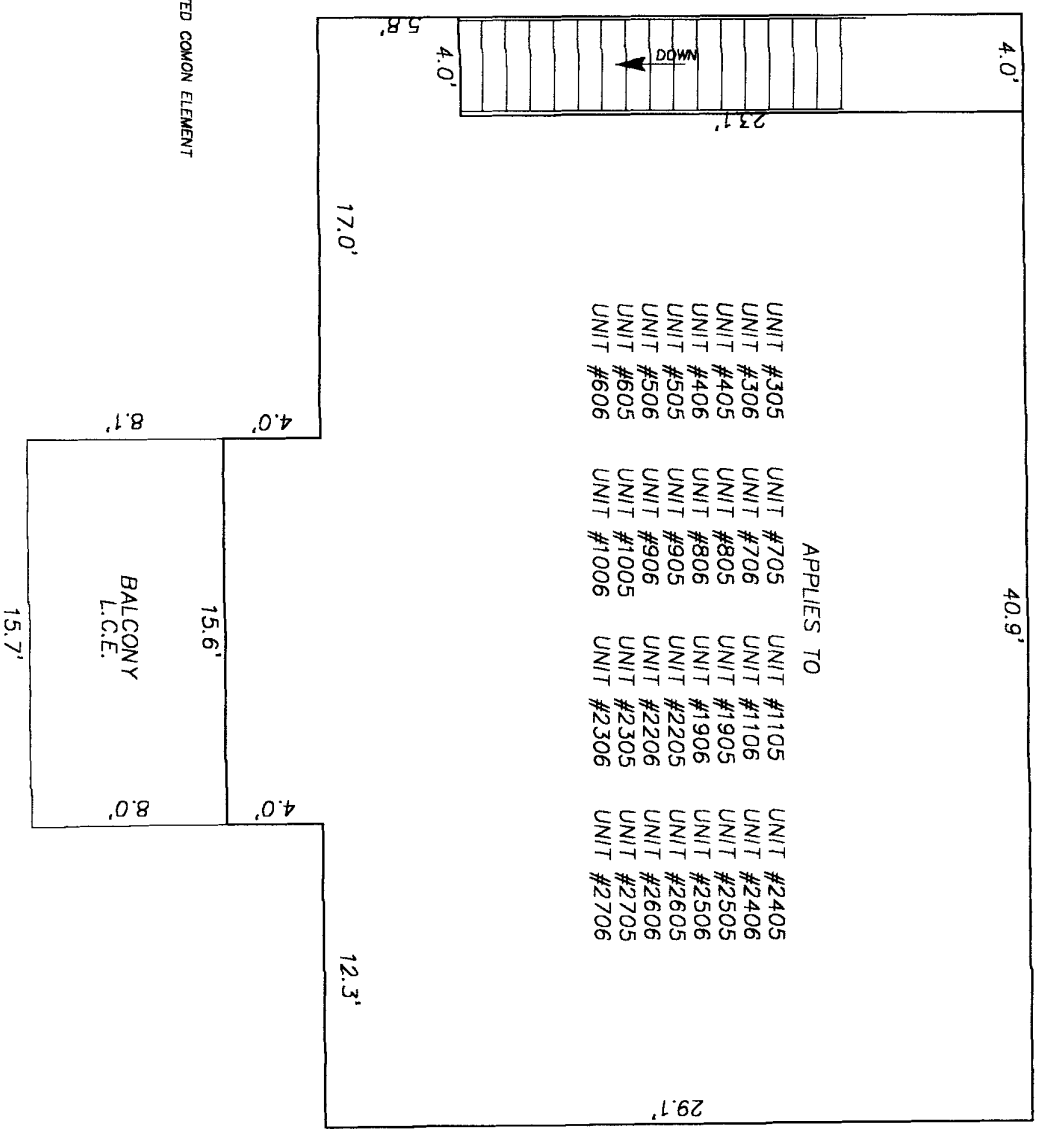

EXHIBIT "B" HERITAGE DEERWOOD, A CONDOMINIUM



APPLIES TO

UNIT #305	UNIT #705	UNIT #1105	UNIT #2405
UNIT #306	UNIT #706	UNIT #1106	UNIT #2406
UNIT #405	UNIT #805	UNIT #1905	UNIT #2505
UNIT #406	UNIT #806	UNIT #1906	UNIT #2506
UNIT #505	UNIT #905	UNIT #2205	UNIT #2605
UNIT #506	UNIT #906	UNIT #2206	UNIT #2606
UNIT #605	UNIT #1005	UNIT #2305	UNIT #2705
UNIT #606	UNIT #1006	UNIT #2306	UNIT #2706

L.C.E.=LIMITED COMMON ELEMENT

RICHARD A. MILLER & ASSOCIATES
 PROFESSIONAL LAND SURVEYORS
 6701 BEACH BLVD. SUITE 100
 JACKSONVILLE, FLORIDA 32225
 (904) 721-5758 (FAX)
 (904) 721-1226 (TEL)

UNIT TYPE B1C PLOT PLAN

AUGUST 25, 2005

SHEET: 22 OF 86

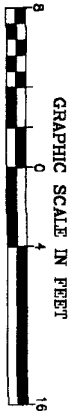
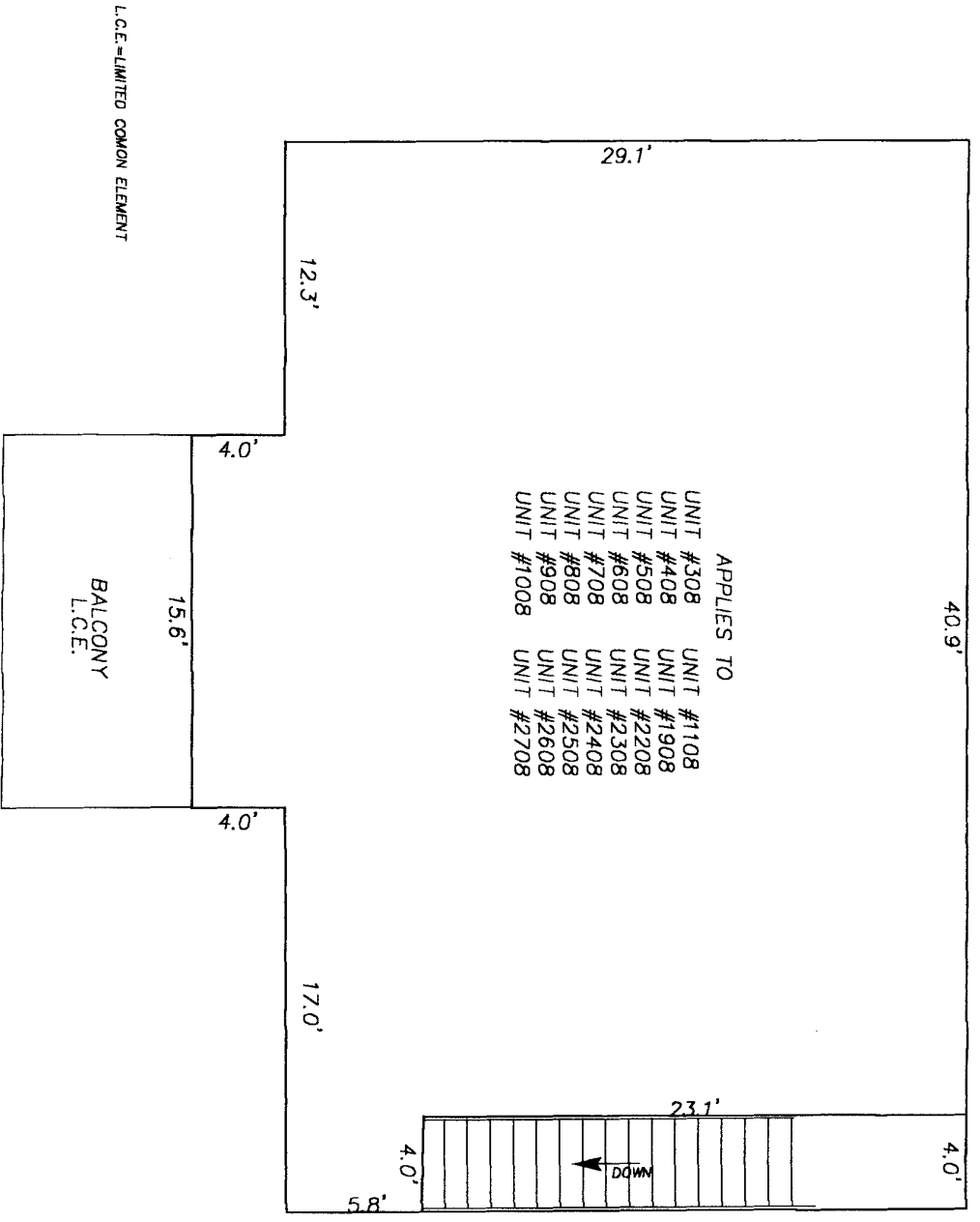

EXHIBIT "B" HERITAGE DEERWOOD, A CONDOMINIUM



APPLIES TO

UNIT #308	UNIT #1108
UNIT #408	UNIT #1908
UNIT #508	UNIT #2208
UNIT #608	UNIT #2308
UNIT #708	UNIT #2408
UNIT #808	UNIT #2508
UNIT #908	UNIT #2608
UNIT #1008	UNIT #2708

UNIT TYPE B1C REVERSE PLOT PLAN

RICHARD A. MILLER & ASSOCIATES
 PROFESSIONAL LAND SURVEYORS
 6701 BEACH BLVD. SUITE 100
 JACKSONVILLE, FLORIDA 32225
 (904) 721-5758 (FAX)
 (904) 721-1226 (TEL)

AUGUST 25, 2005

SHEET: 23 OF 86

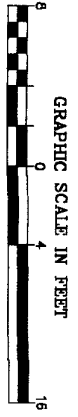
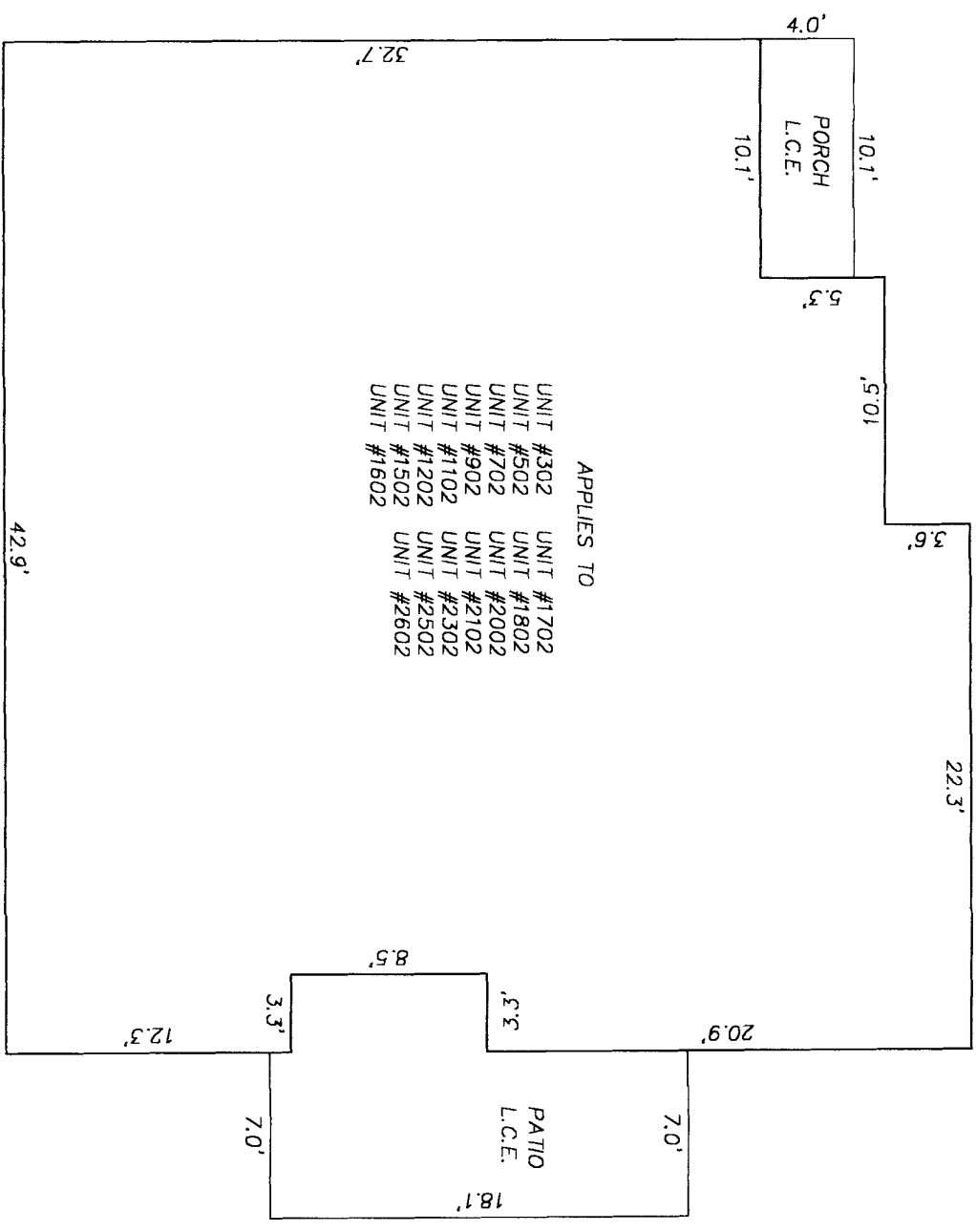

EXHIBIT "B" HERITAGE DEERWOOD, A CONDOMINIUM



L.C.E. = LIMITED COMMON ELEMENT

RICHARD A. MILLER & ASSOCIATES
 PROFESSIONAL LAND SURVEYORS
 6701 BEACH BLVD. SUITE 100
 JACKSONVILLE, FLORIDA 32225
 (904) 721-5758 (FAX)
 (904) 721-1226 (TEL)

UNIT TYPE C1A PLOT PLAN

AUGUST 25, 2005

SHEET: 24 OF 86

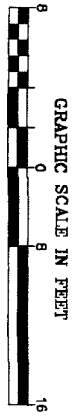
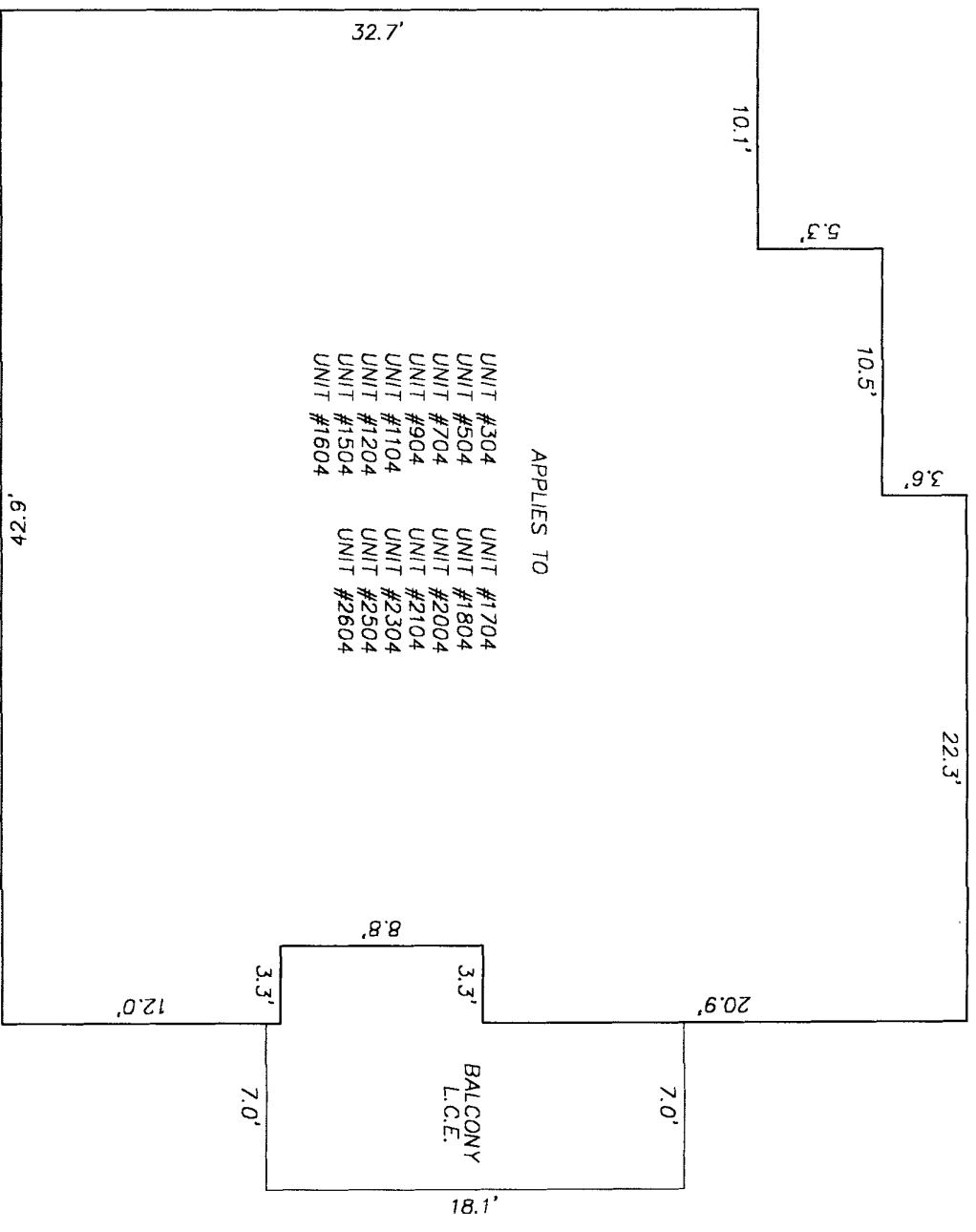

EXHIBIT "B" HERITAGE DEERWOOD, A CONDOMINIUM

L.C.E. = LIMITED COMMON ELEMENT



RICHARD A. MILLER & ASSOCIATES
 PROFESSIONAL LAND SURVEYORS
 6701 BEACH BLVD. SUITE 100
 JACKSONVILLE, FLORIDA 32225
 (904) 721-5758 (FAX)
 (904) 721-1226 (TEL)

UNIT TYPE C1B PLOT PLAN

AUGUST 25, 2005

SHEET: 25 OF 86

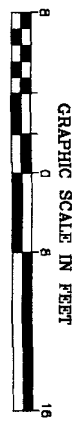
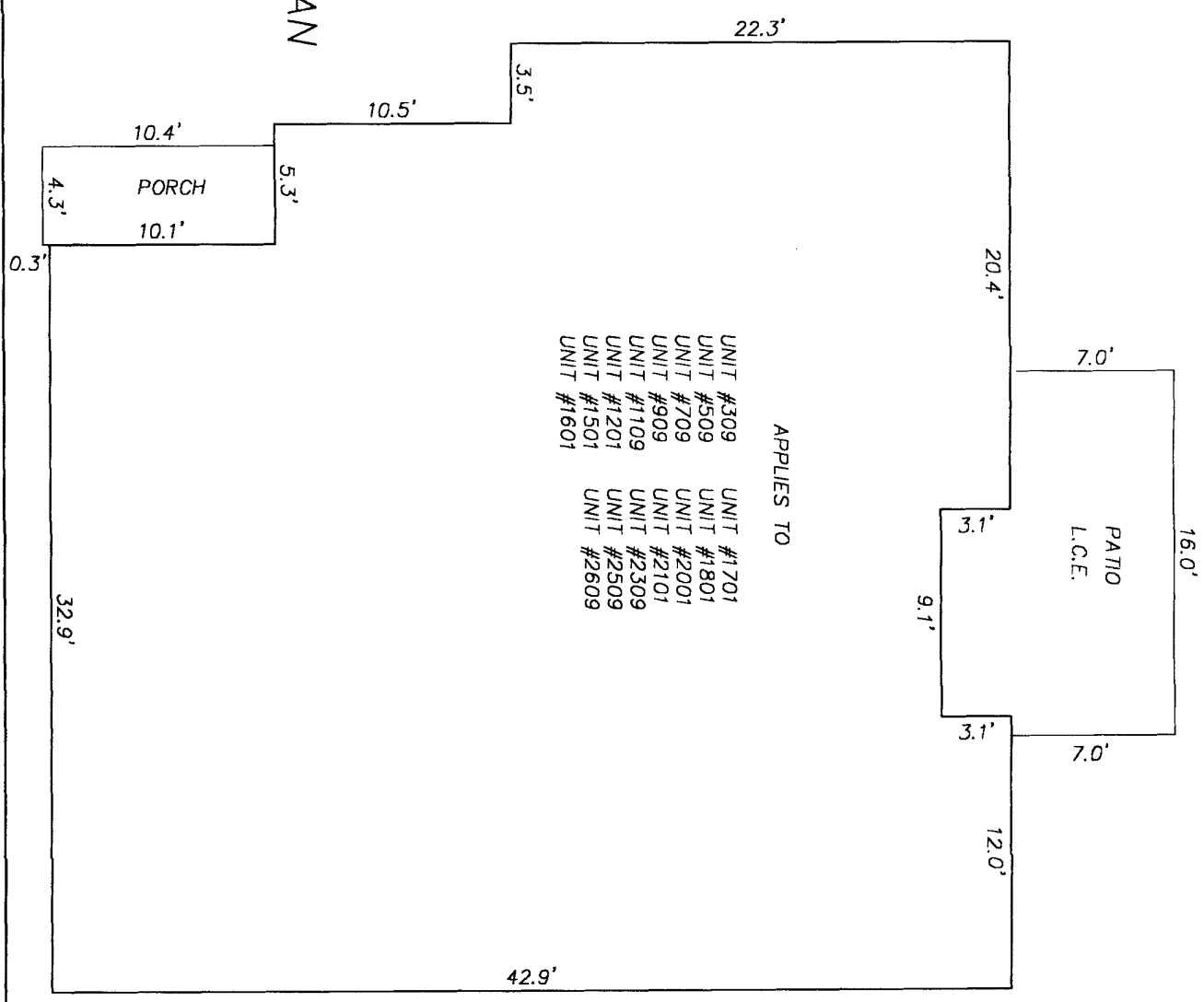

EXHIBIT "B" HERITAGE DEERWOOD, A CONDOMINIUM

UNIT TYPE C1C PLOT PLAN

RICHARD A. MILLER & ASSOCIATES
PROFESSIONAL LAND SURVEYORS
6701 BEACH BLVD, SUITE 100
JACKSONVILLE, FLORIDA 32225
(904) 721-5758 (FAX)
(904) 721-1226 (TEL)



- APPLIES TO
- | | |
|------------|------------|
| UNIT #309 | UNIT #1701 |
| UNIT #509 | UNIT #1801 |
| UNIT #709 | UNIT #2001 |
| UNIT #909 | UNIT #2101 |
| UNIT #1109 | UNIT #2309 |
| UNIT #1201 | UNIT #2509 |
| UNIT #1501 | UNIT #2609 |
| UNIT #1601 | |

L.C.E. = LIMITED COMMON ELEMENT



EXHIBIT "B" HERITAGE DEERWOOD, A CONDOMINIUM

UNIT TYPE C1D PLOT PLAN

RICHARD A. MILLER & ASSOCIATES
PROFESSIONAL LAND SURVEYORS
6701 BEACH BLVD. SUITE 100
JACKSONVILLE, FLORIDA 32225
(904) 721-5758 (FAX)
(904) 721-1226 (TEL)

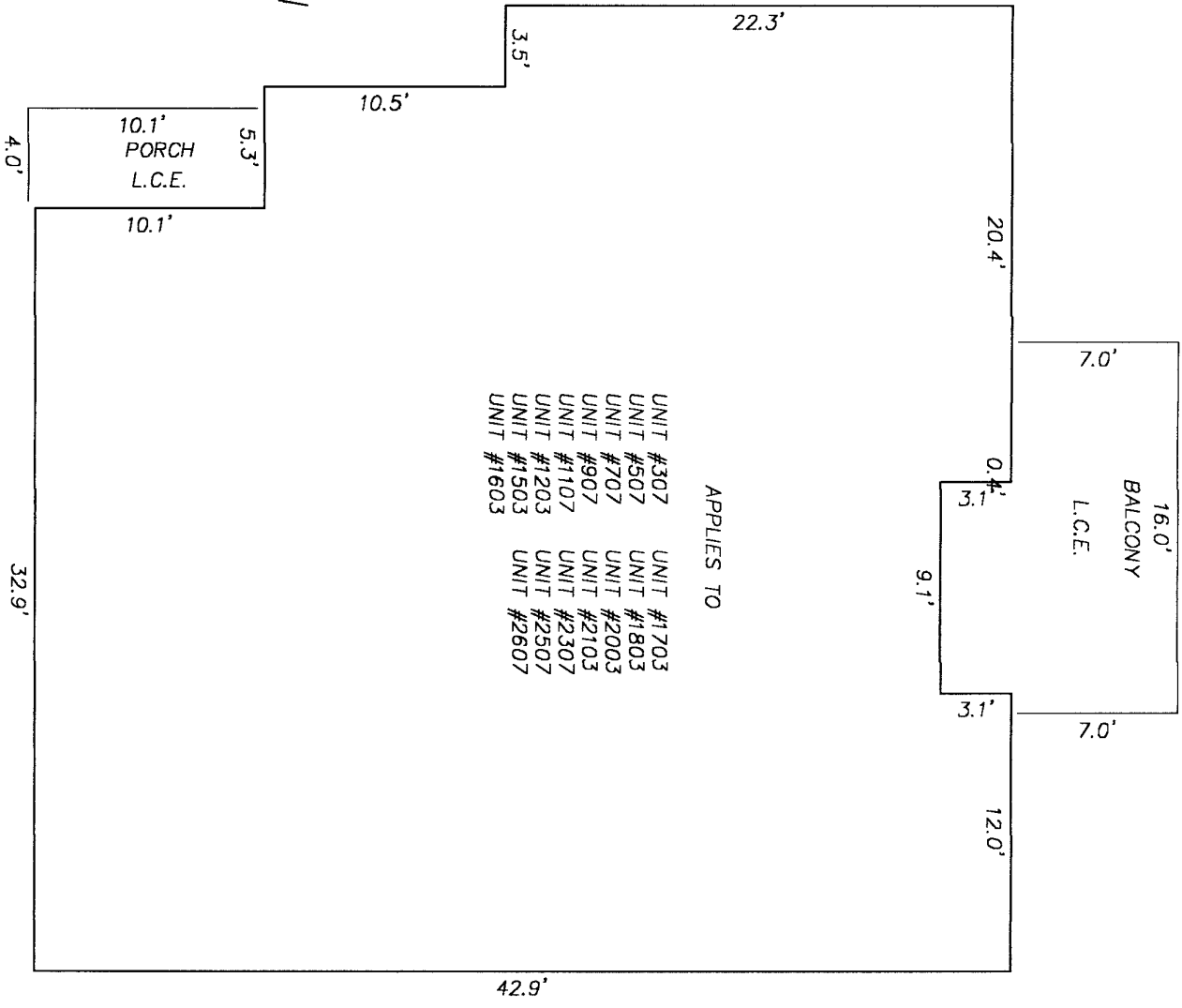

L.C.E. = LIMITED COMMON ELEMENT

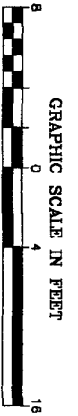
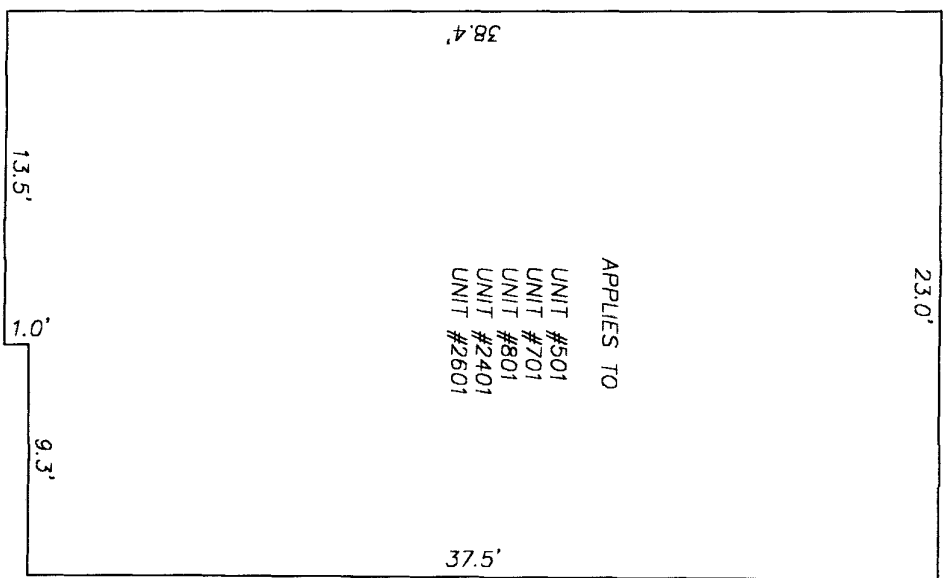
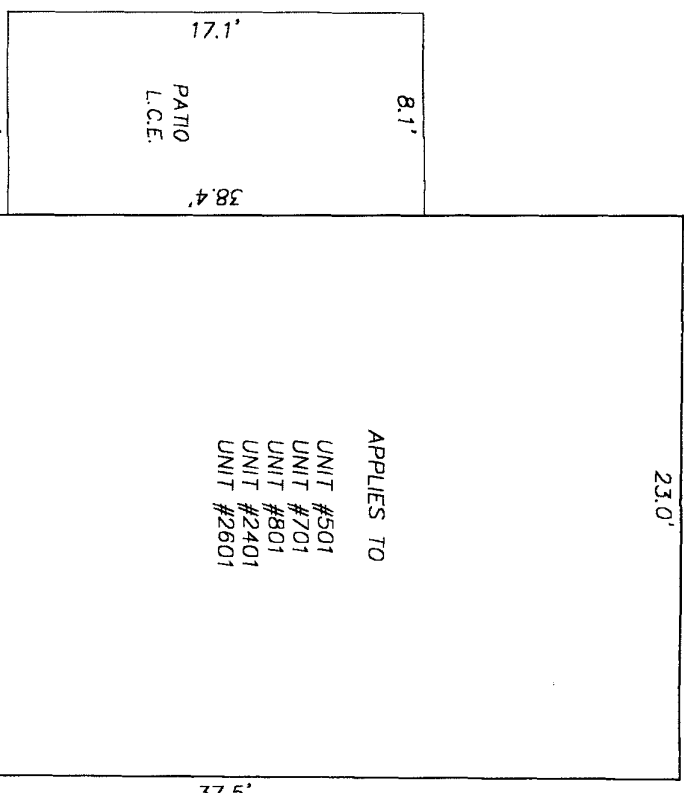

EXHIBIT "B" HERITAGE DEERWOOD, A CONDOMINIUM



UNIT D1 SECOND FLOOR



UNIT D1 FIRST FLOOR

UNIT TYPE D1 PLOT PLAN

RICHARD A. MILLER & ASSOCIATES
 PROFESSIONAL LAND SURVEYORS
 6701 BEACH BLVD., SUITE 100
 JACKSONVILLE, FLORIDA 32225
 (904) 721-5758 (FAX)
 (904) 721-1226 (TEL)

L.C.E.=LIMITED COMMON ELEMENT

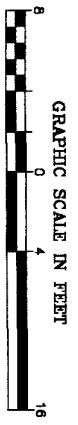
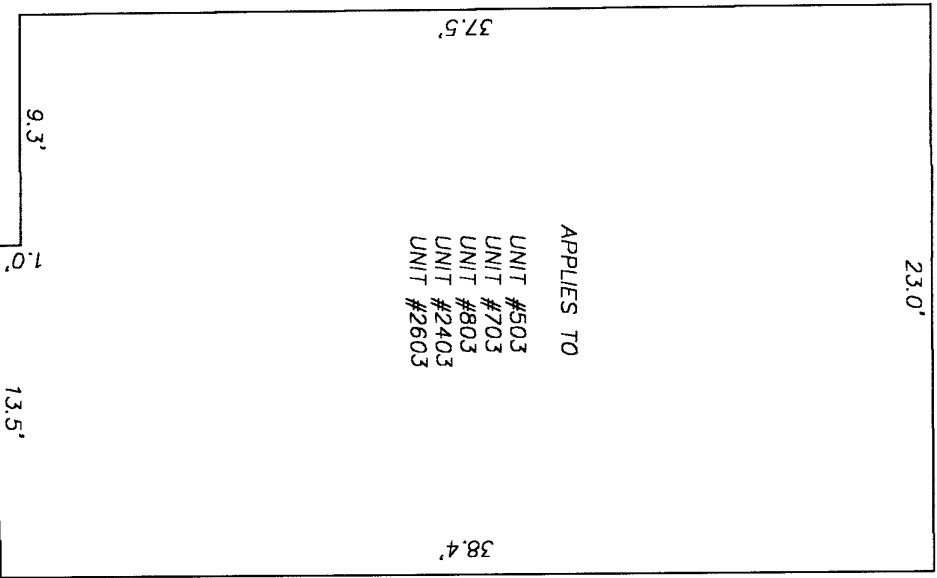
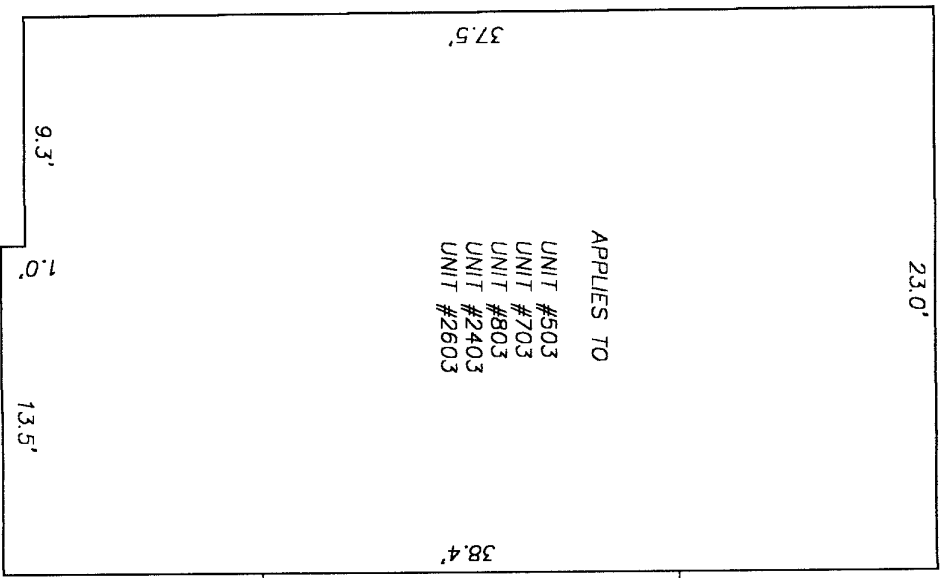

EXHIBIT "B" HERITAGE DEERWOOD, A CONDOMINIUM



UNIT D1 SECOND FLOOR



UNIT D1 FIRST FLOOR

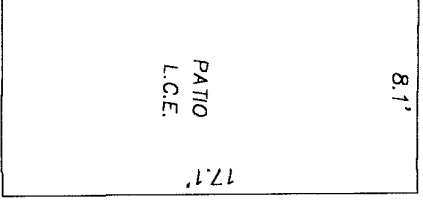

PATIO
L.C.E.

UNIT TYPE D1 REVERSE PLOT PLAN

RICHARD A. MILLER & ASSOCIATES
 PROFESSIONAL LAND SURVEYORS
 6701 BEACH BLVD., SUITE 100
 JACKSONVILLE, FLORIDA 32225
 (904) 721-5758 (FAX)
 (904) 721-1226 (TEL)

AUGUST 25, 2005

SHEET: 29 OF 86

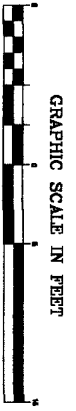
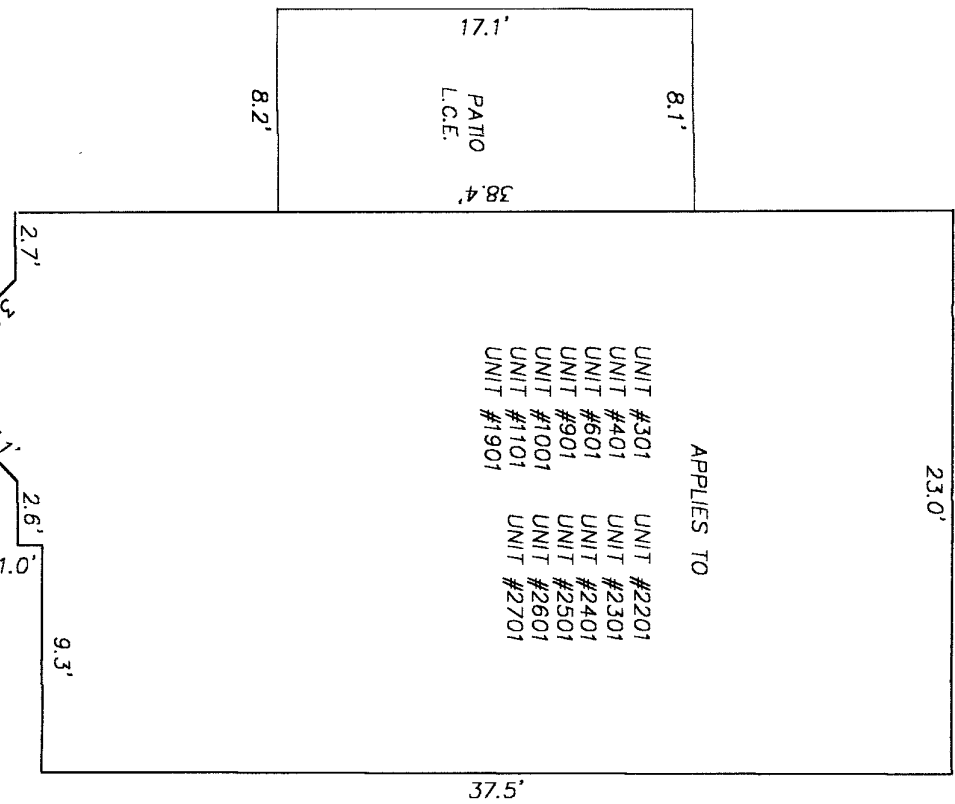
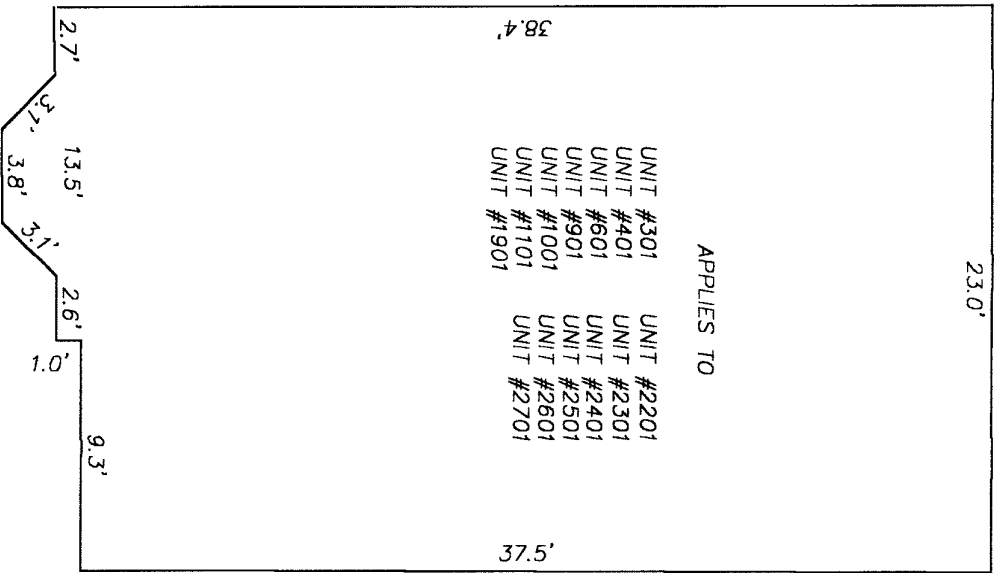

EXHIBIT "B" HERITAGE DEERWOOD, A CONDOMINIUM



RICHARD A. MILLER & ASSOCIATES
 PROFESSIONAL LAND SURVEYORS
 6701 BEACH BLVD. SUITE 100
 JACKSONVILLE, FLORIDA 32225
 (904) 721-5758 (FAX)
 (904) 721-1226 (TEL)

UNIT D2 PLOT PLAN

L.C.E.=LIMITED COMMON ELEMENT

AUGUST 25, 2005

SHEET: 30 OF 86

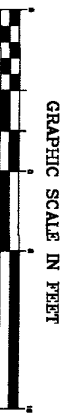
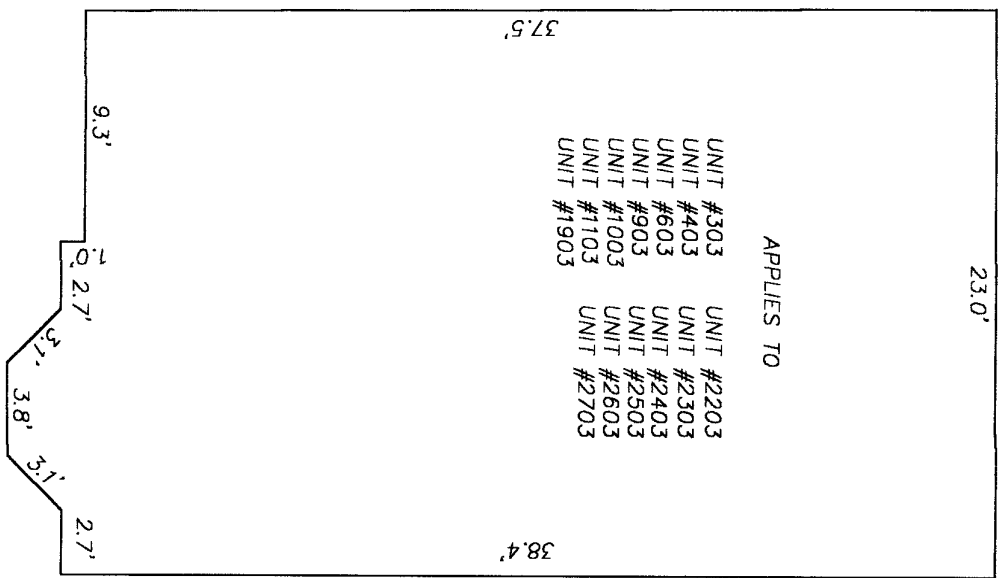
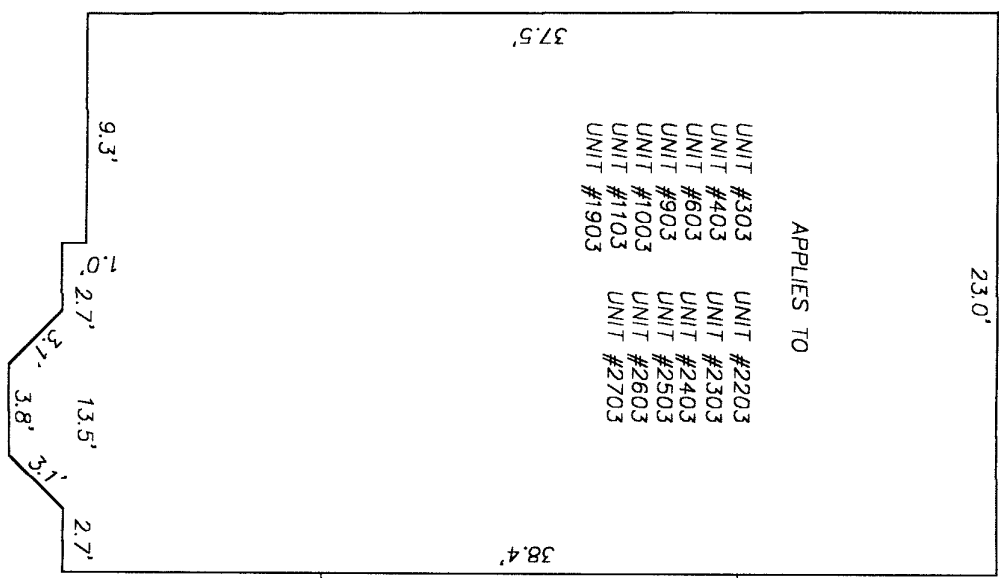

EXHIBIT "B" HERITAGE DEERWOOD, A CONDOMINIUM

L.C.E.=LIMITED COMMON ELEMENT



UNIT D2 SECOND FLOOR



UNIT D2 FIRST FLOOR

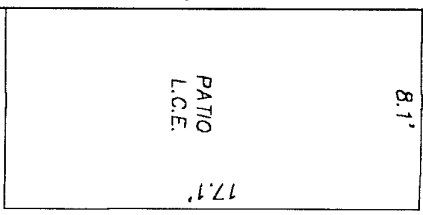

UNIT D2 REVERSE FLOOR PLAN

RICHARD A. MILLER & ASSOCIATES
PROFESSIONAL LAND SURVEYORS
6701 BEACH BLVD. SUITE 100
JACKSONVILLE, FLORIDA 32225
(904) 721-5758 (FAX)
(904) 721-1226 (TEL)

AUGUST 25, 2005

SHEET: 31 OF 86

EXHIBIT "B" HERITAGE DEERWOOD, A CONDOMINIUM

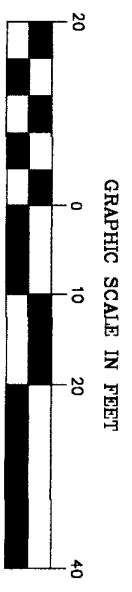
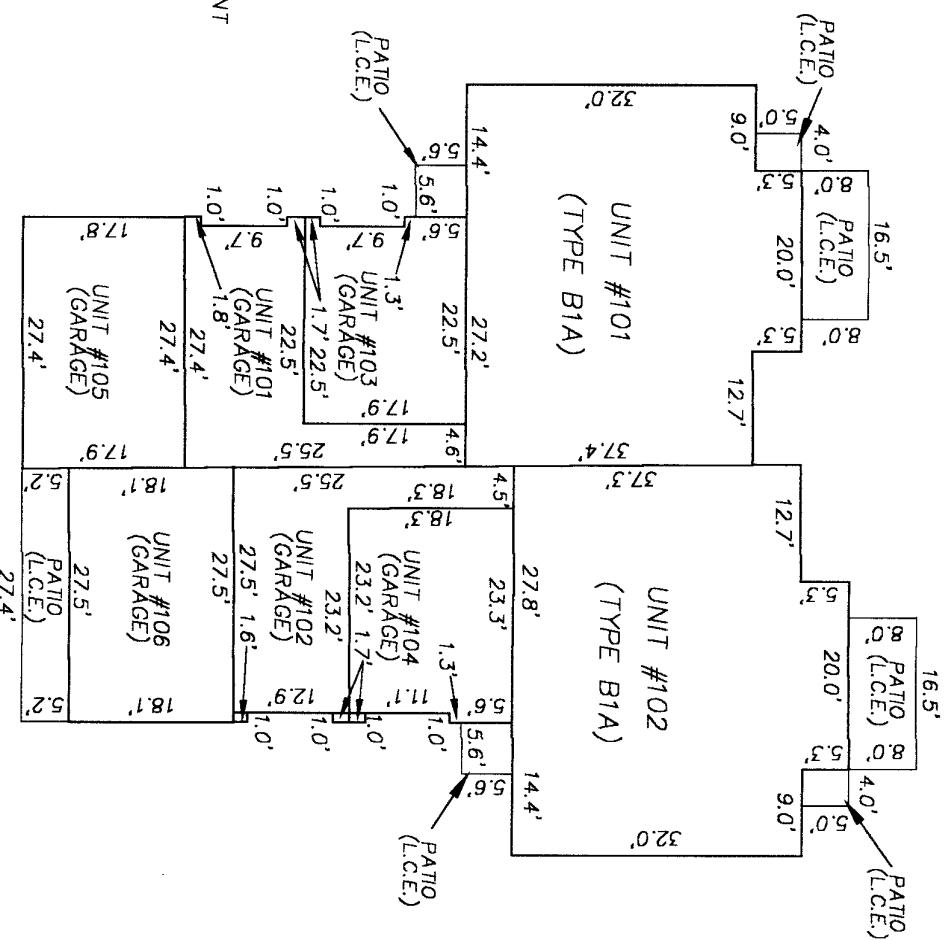

BUILDING 100 PLOT PLAN FIRST FLOOR

RICHARD A. MILLER & ASSOCIATES
 PROFESSIONAL LAND SURVEYORS
 6701 BEACH BLVD. SUITE 100
 JACKSONVILLE, FLORIDA 32225
 (904) 721-5758 (FAX)
 (904) 721-1228 (TEL)

EXHIBIT "B" HERITAGE DEERWOOD, A CONDOMINIUM

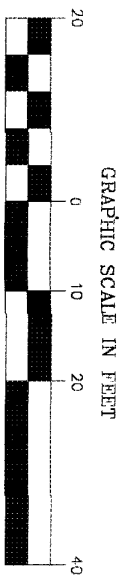
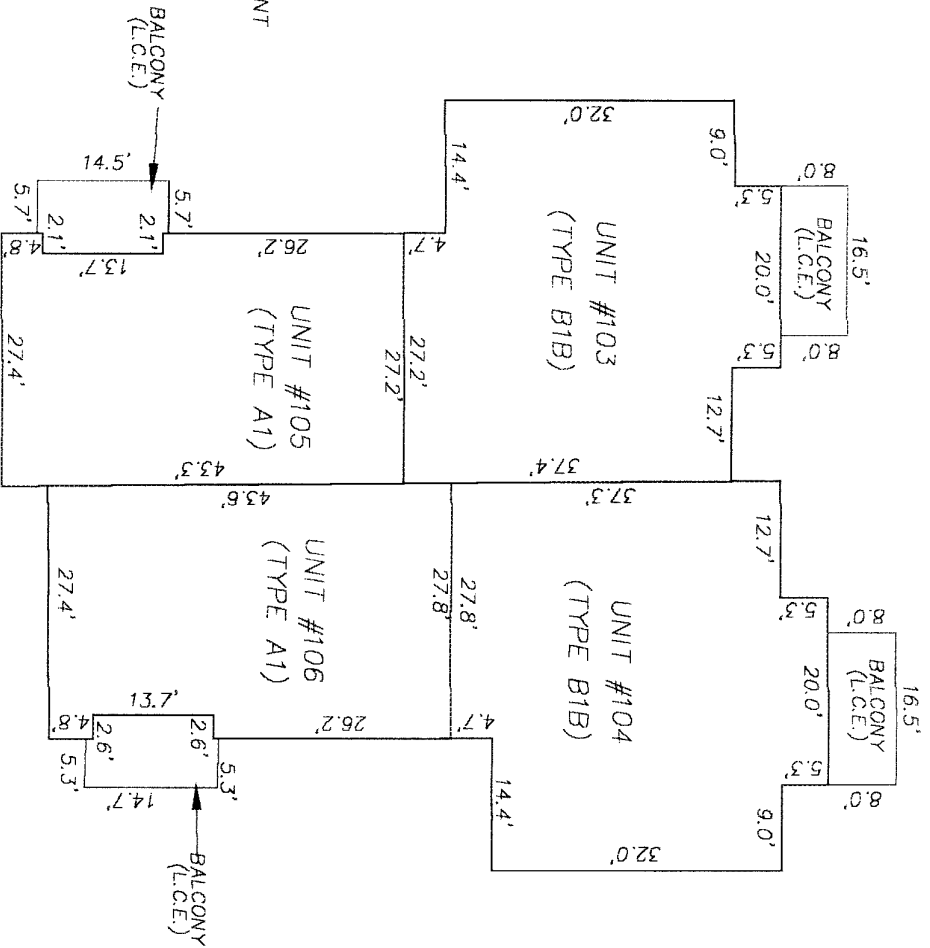

RICHARD A. MILLER & ASSOCIATES
 PROFESSIONAL LAND SURVEYORS
 6701 BEACH BLVD., SUITE 100
 JACKSONVILLE, FLORIDA 32225
 (904) 721-5758 (FAX)
 (904) 721-1226 (TEL)

BUILDING 100 PLOT PLAN
 SECOND FLOOR

EXHIBIT "B"

HERITAGE DEERWOOD, A CONDOMINIUM

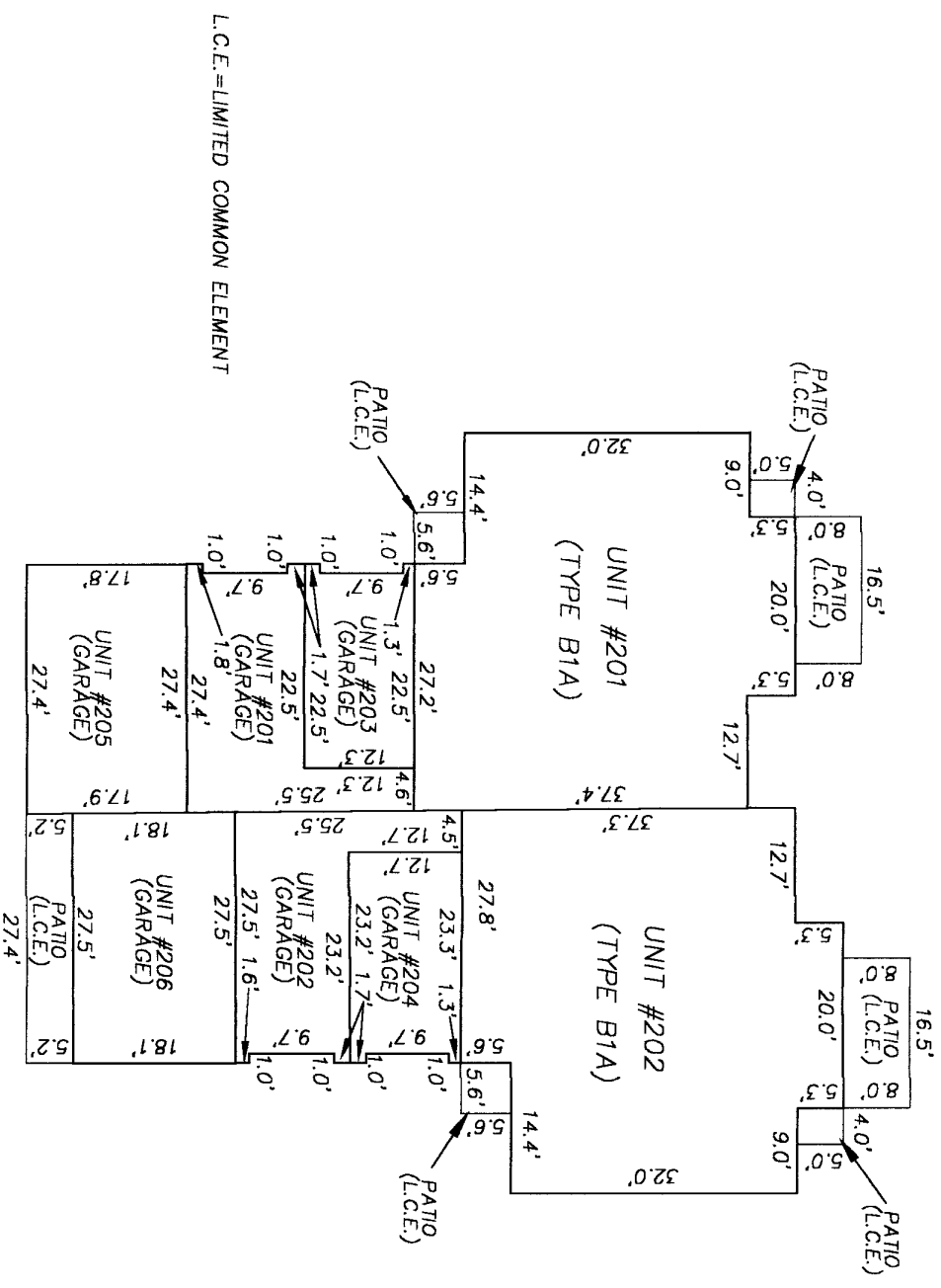
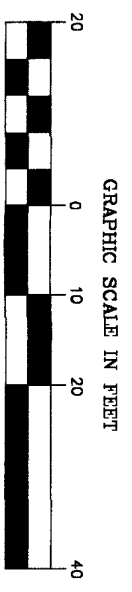

BUILDING 200 PLOT PLAN FIRST FLOOR

RICHARD A. MILLER & ASSOCIATES
 PROFESSIONAL LAND SURVEYORS
 6701 BEACH BLVD. SUITE 100
 JACKSONVILLE, FLORIDA 32225
 (904) 721-5758 (FAX)
 (904) 721-1226 (TEL)

EXHIBIT "B" HERITAGE DEERWOOD, A CONDOMINIUM

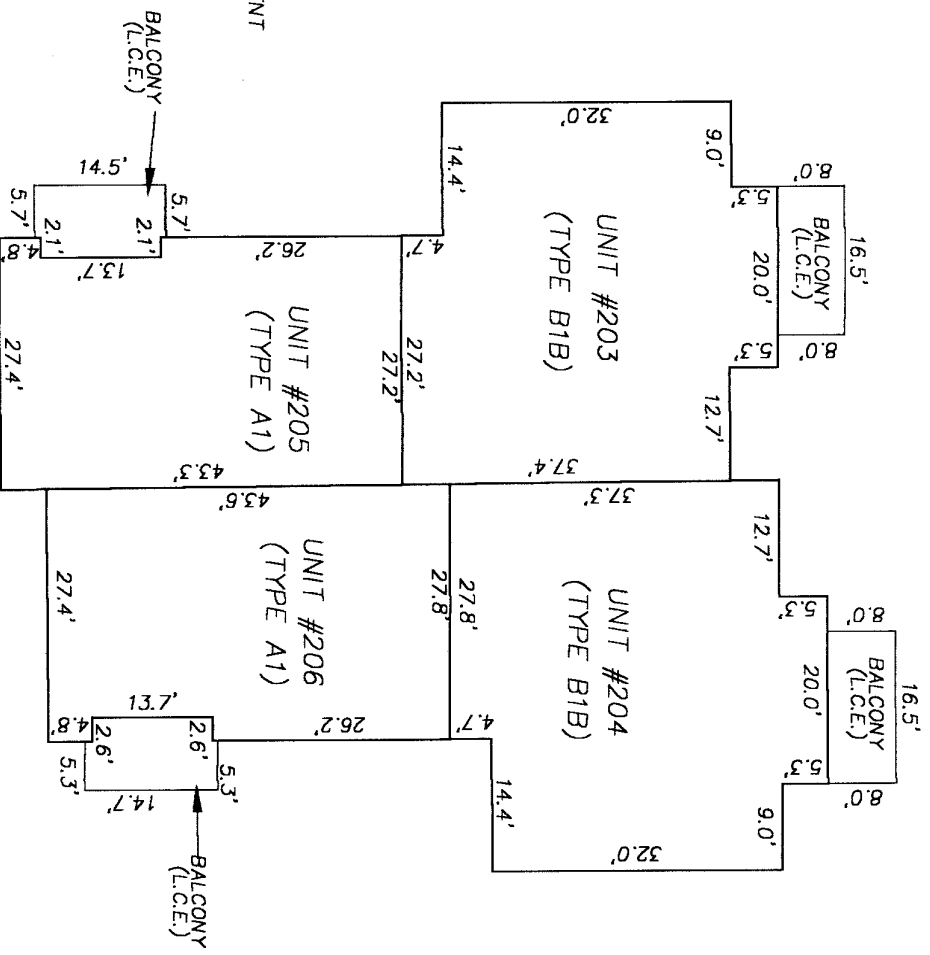
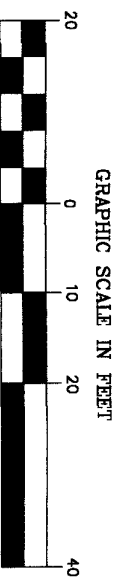

L.C.E.=LIMITED COMMON ELEMENT

RICHARD A. MILLER & ASSOCIATES
 PROFESSIONAL LAND SURVEYORS
 6701 BEACH BLVD., SUITE 100
 JACKSONVILLE, FLORIDA 32225
 (904) 721-5758 (FAX)
 (904) 721-1226 (TEL)

BUILDING 200 PLOT PLAN
 SECOND FLOOR

EXHIBIT "B" HERITAGE DEERWOOD, A CONDOMINIUM

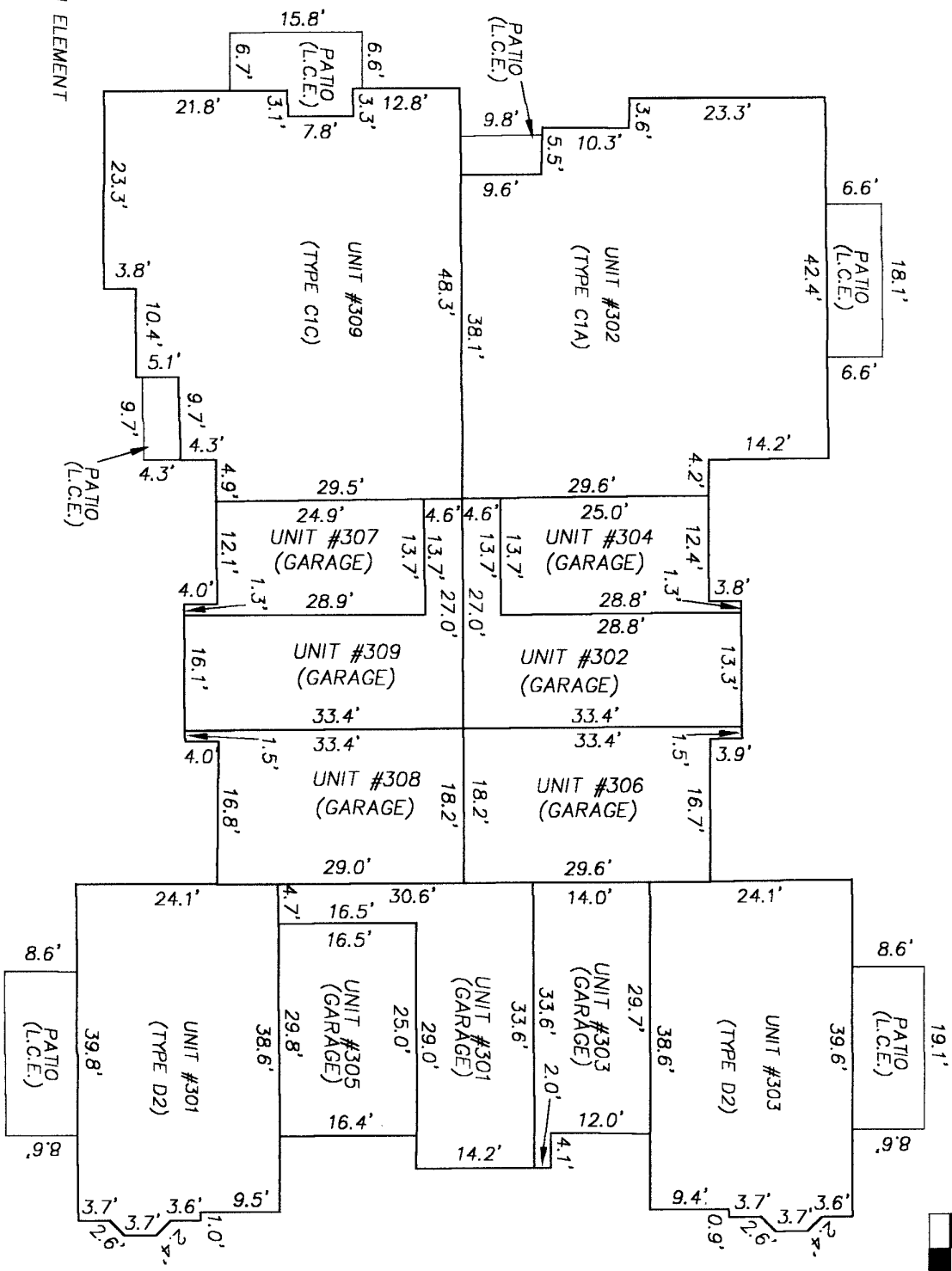
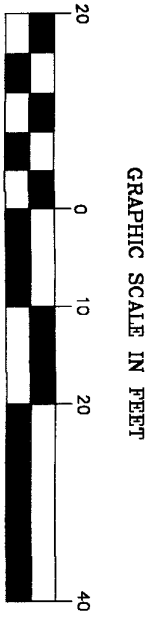

L.C.E.=LIMITED COMMON ELEMENT

RICHARD A. MILLER & ASSOCIATES
 PROFESSIONAL LAND SURVEYORS
 6701 BEACH BLVD. SUITE 100
 JACKSONVILLE, FLORIDA 32225
 (904) 721-5758 (FAX)
 (904) 721-1226 (TEL)

BUILDING 300 PLOT PLAN FIRST FLOOR

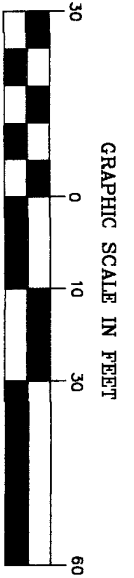
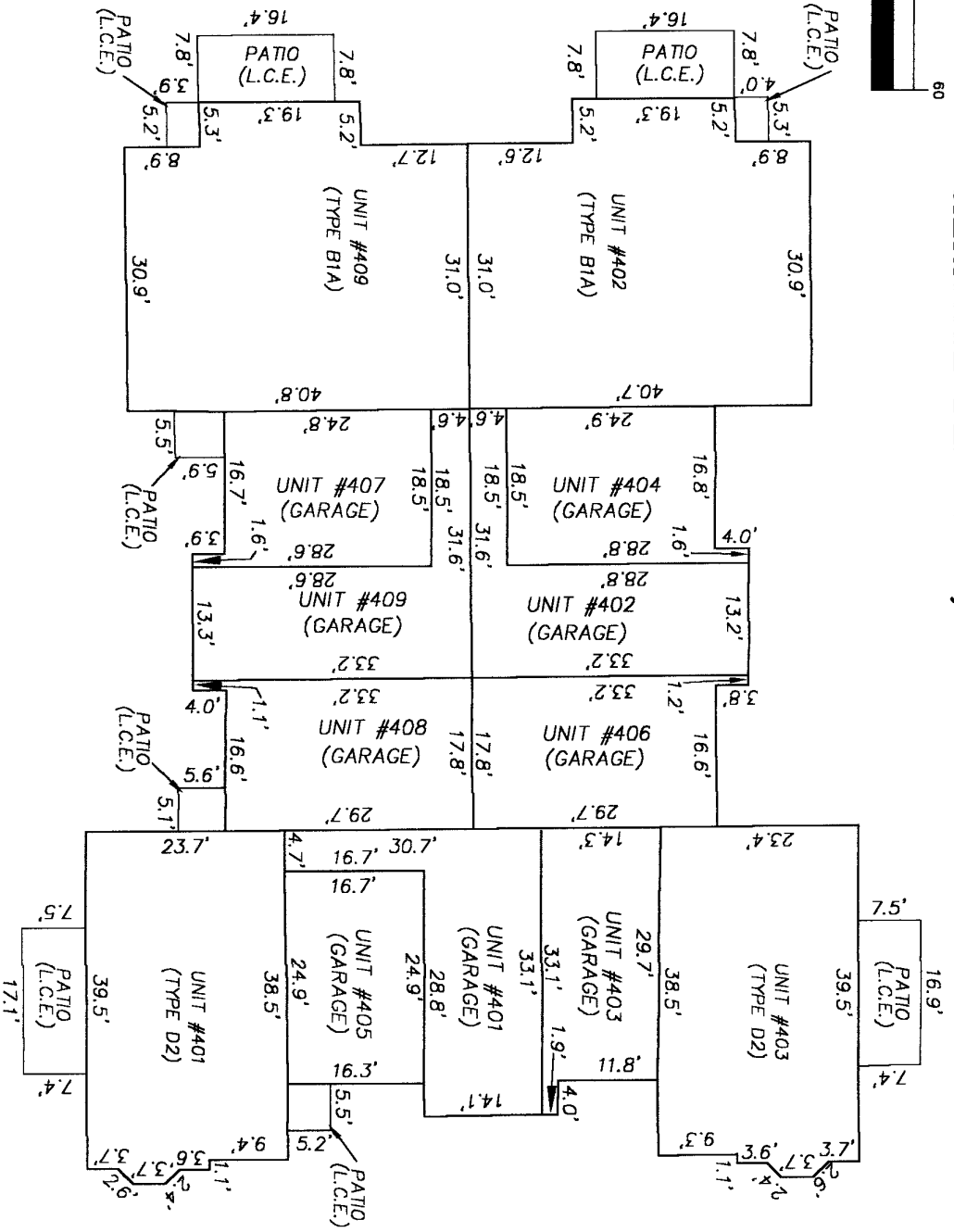

EXHIBIT "B"
HERITAGE DEERWOOD, A CONDOMINIUM



BUILDING 400 PLOT PLAN
FIRST FLOOR

RICHARD A. MILLER & ASSOCIATES
 PROFESSIONAL LAND SURVEYORS
 6701 BEACH BLVD., SUITE 100
 JACKSONVILLE, FLORIDA 32225
 (904) 721-5758 (FAX)
 (904) 721-1226 (TEL)

EXHIBIT "B" HERITAGE DEERWOOD, A CONDOMINIUM

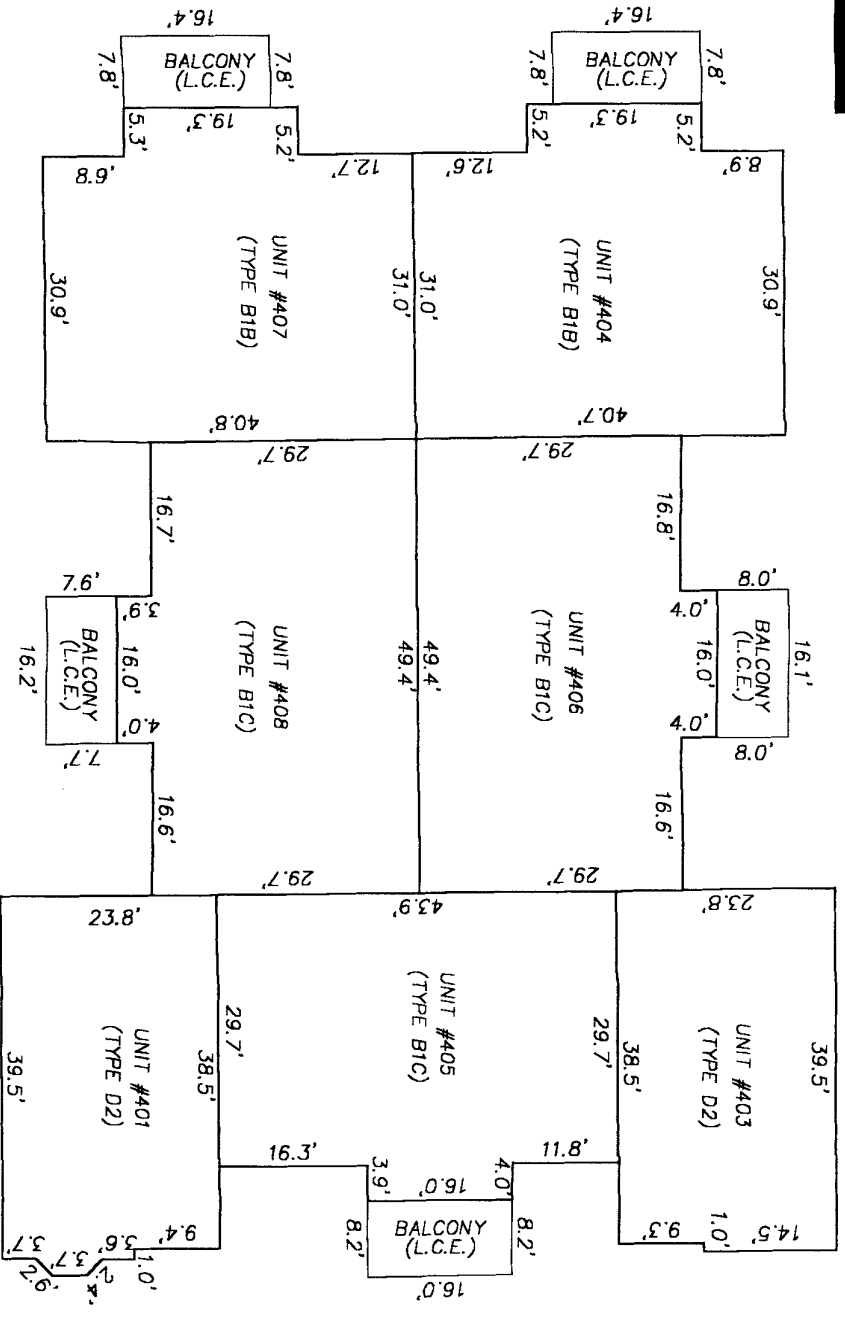
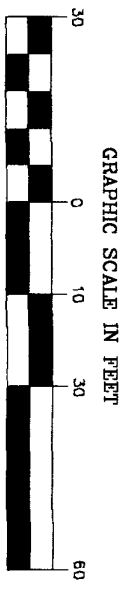

BUILDING 400 PLOT PLAN SECOND FLOOR

RICHARD A. MILLER & ASSOCIATES
PROFESSIONAL LAND SURVEYORS
6701 BEACH BLVD., SUITE 100
JACKSONVILLE, FLORIDA 32225
(904) 721-5758 (FAX)
(904) 721-1226 (TEL)



EXHIBIT "B" HERITAGE DEERWOOD, A CONDOMINIUM

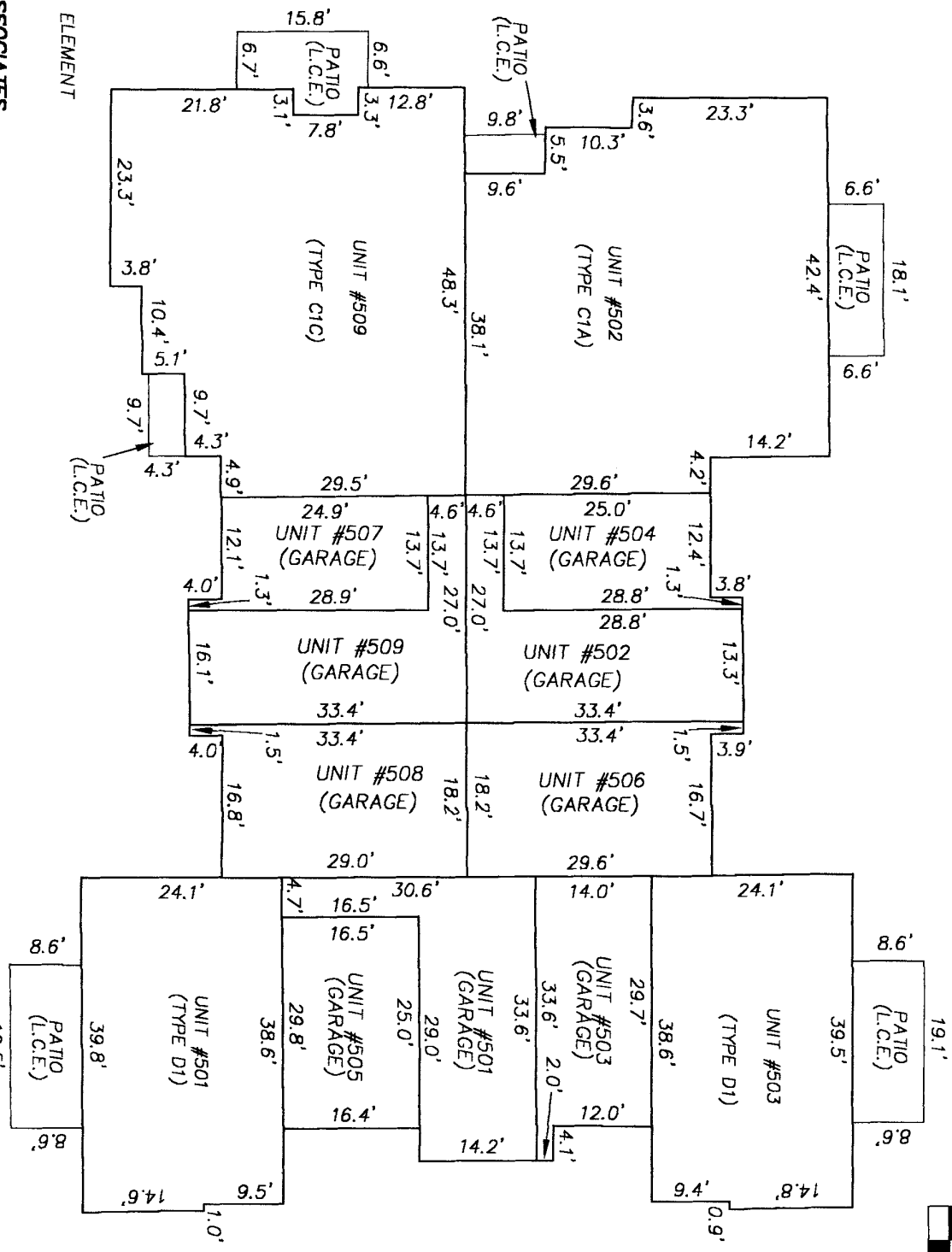
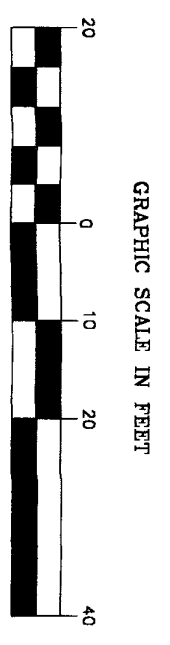

L.C.E. = LIMITED COMMON ELEMENT

RICHARD A. MILLER & ASSOCIATES
 PROFESSIONAL LAND SURVEYORS
 6701 BEACH BLVD. SUITE 100
 JACKSONVILLE, FLORIDA 32225
 (904) 721-5758 (FAX)
 (904) 721-1226 (TEL)

BUILDING 500 PLOT PLAN FIRST FLOOR

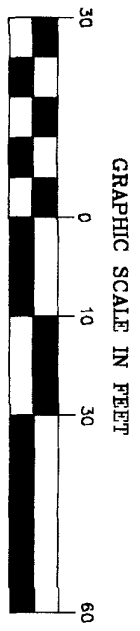
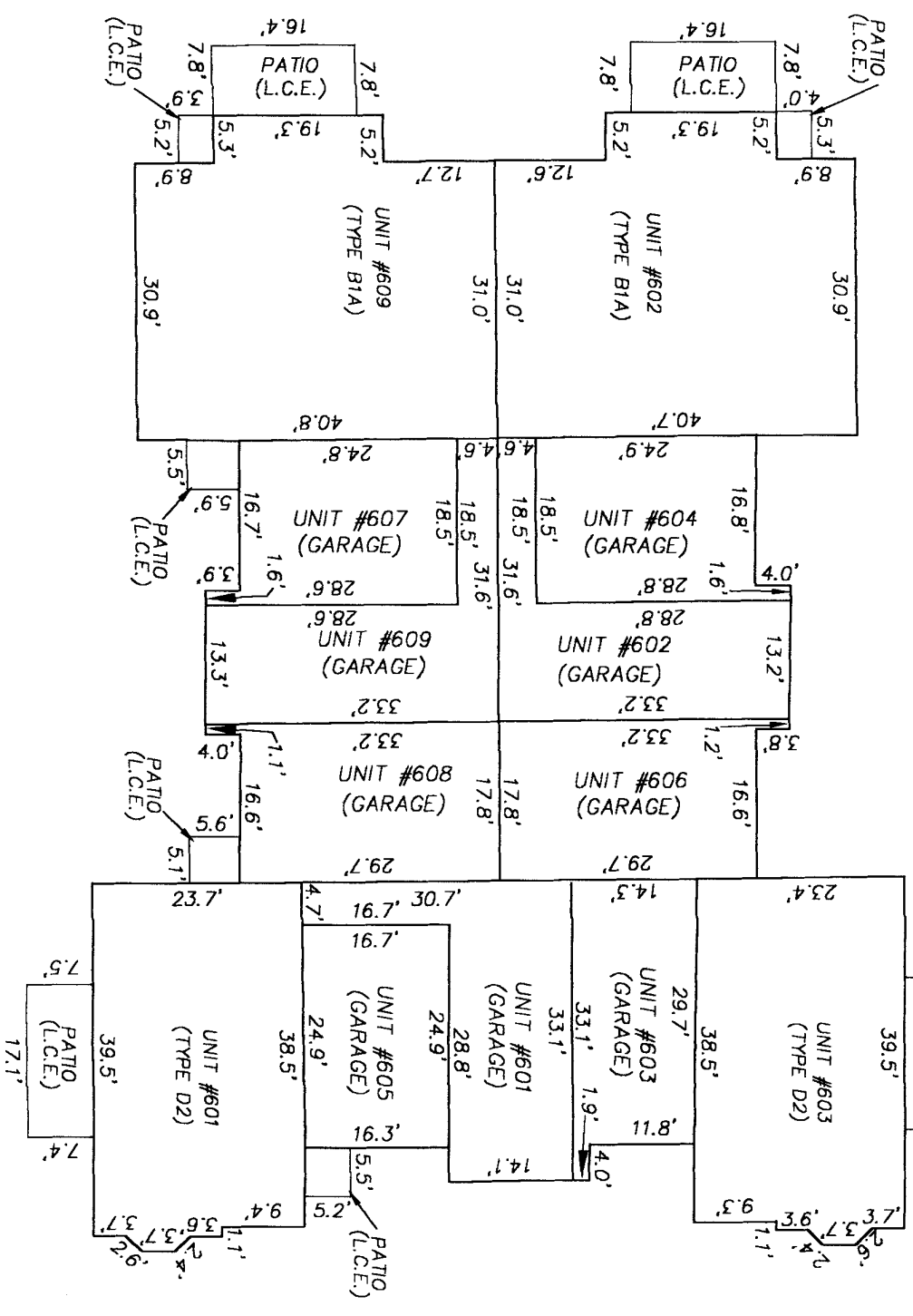

EXHIBIT "B" HERITAGE DEERWOOD, A CONDOMINIUM



L.C.E.=LIMITED COMMON ELEMENT

BUILDING 600 PLOT PLAN FIRST FLOOR

RICHARD A. MILLER & ASSOCIATES
PROFESSIONAL LAND SURVEYORS
6701 BEACH BLVD., SUITE 100
JACKSONVILLE, FLORIDA 32225
(904) 721-5758 (FAX)
(904) 721-1226 (TEL)

GRAPHIC SCALE IN FEET

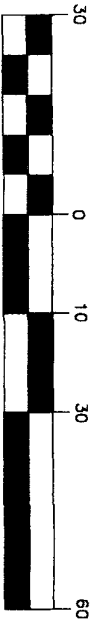
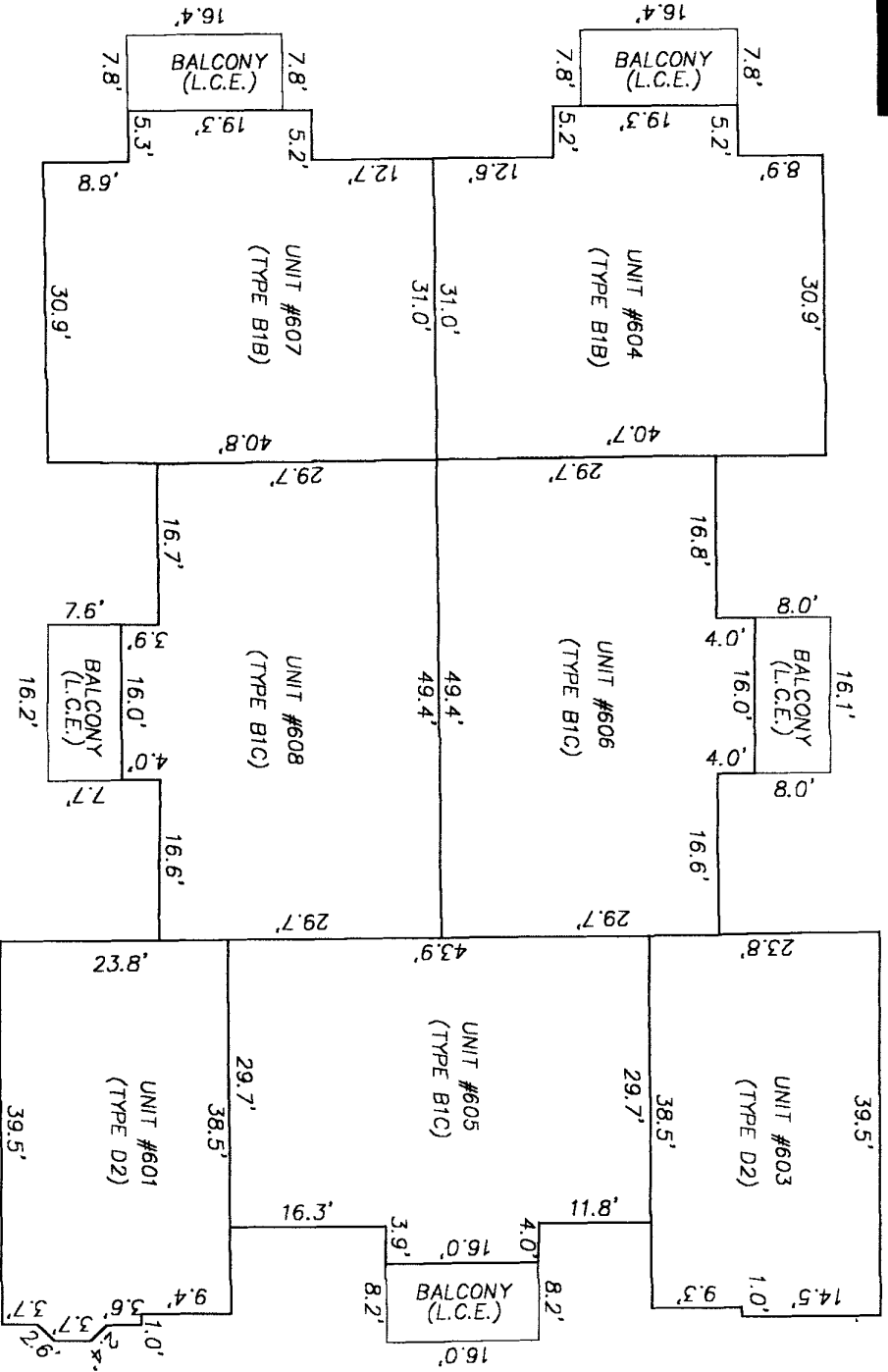

EXHIBIT "B"

HERITAGE DEERWOOD, A CONDOMINIUM



BUILDING 600 PLOT PLAN SECOND FLOOR

RICHARD A. MILLER & ASSOCIATES
 PROFESSIONAL LAND SURVEYORS
 6701 BEACH BLVD., SUITE 100
 JACKSONVILLE, FLORIDA 32225
 (904) 721-5758 (FAX)
 (904) 721-1226 (TEL)

AUGUST 25, 2005

SHEET: 43 OF 86

EXHIBIT "B" HERITAGE DEERWOOD, A CONDOMINIUM

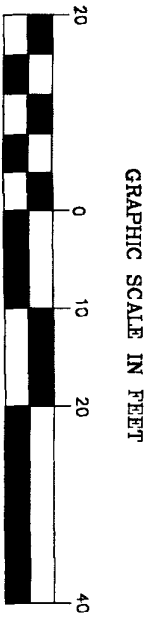
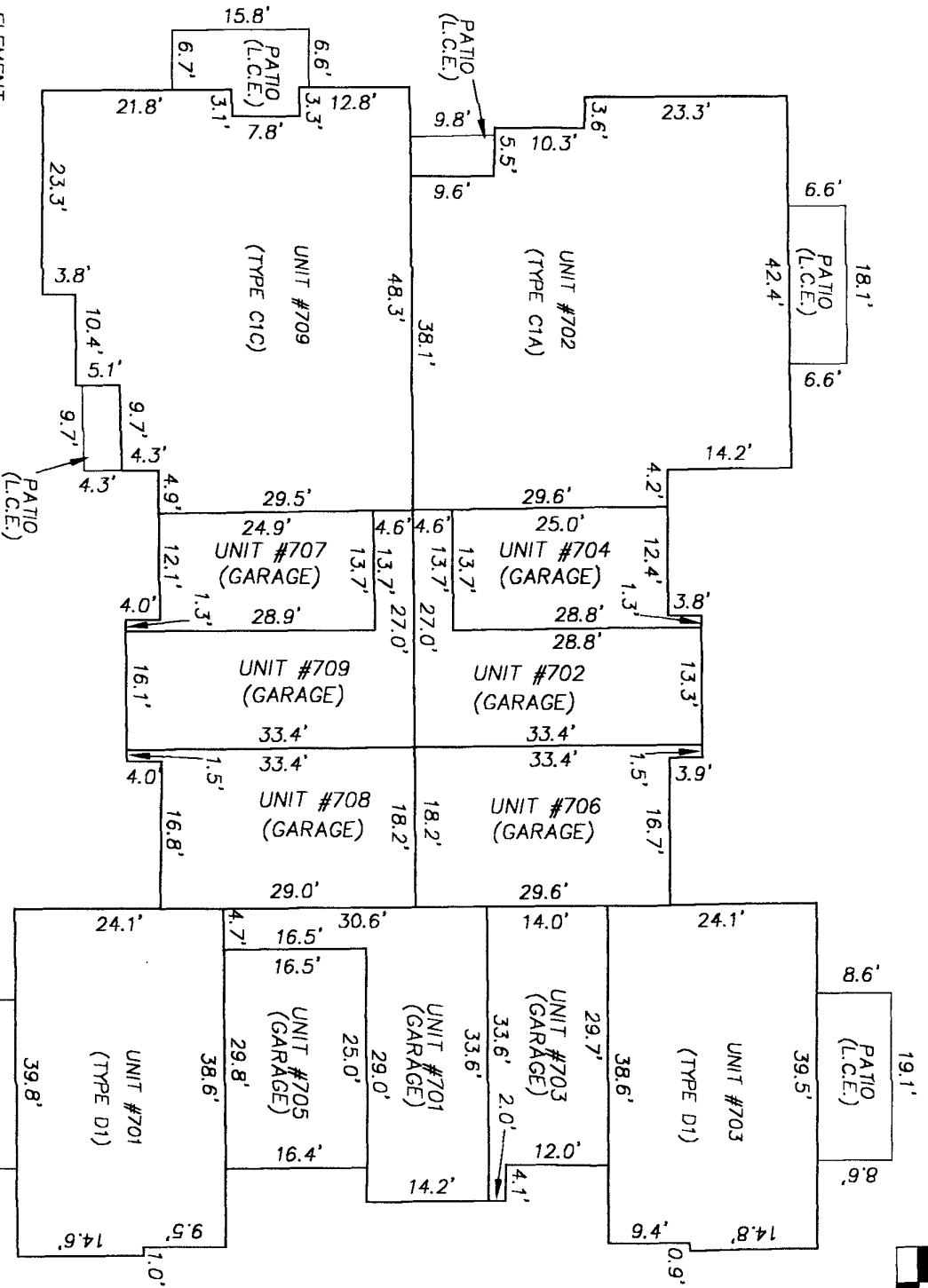

L.C.E.=LIMITED COMMON ELEMENT

RICHARD A. MILLER & ASSOCIATES
 PROFESSIONAL LAND SURVEYORS
 6701 BEACH BLVD, SUITE 100
 JACKSONVILLE, FLORIDA 32225
 (904) 721-5758 (FAX)
 (904) 721-1226 (TEL)

BUILDING 700 PLOT PLAN FIRST FLOOR

EXHIBIT "B"
HERITAGE DEERWOOD, A CONDOMINIUM

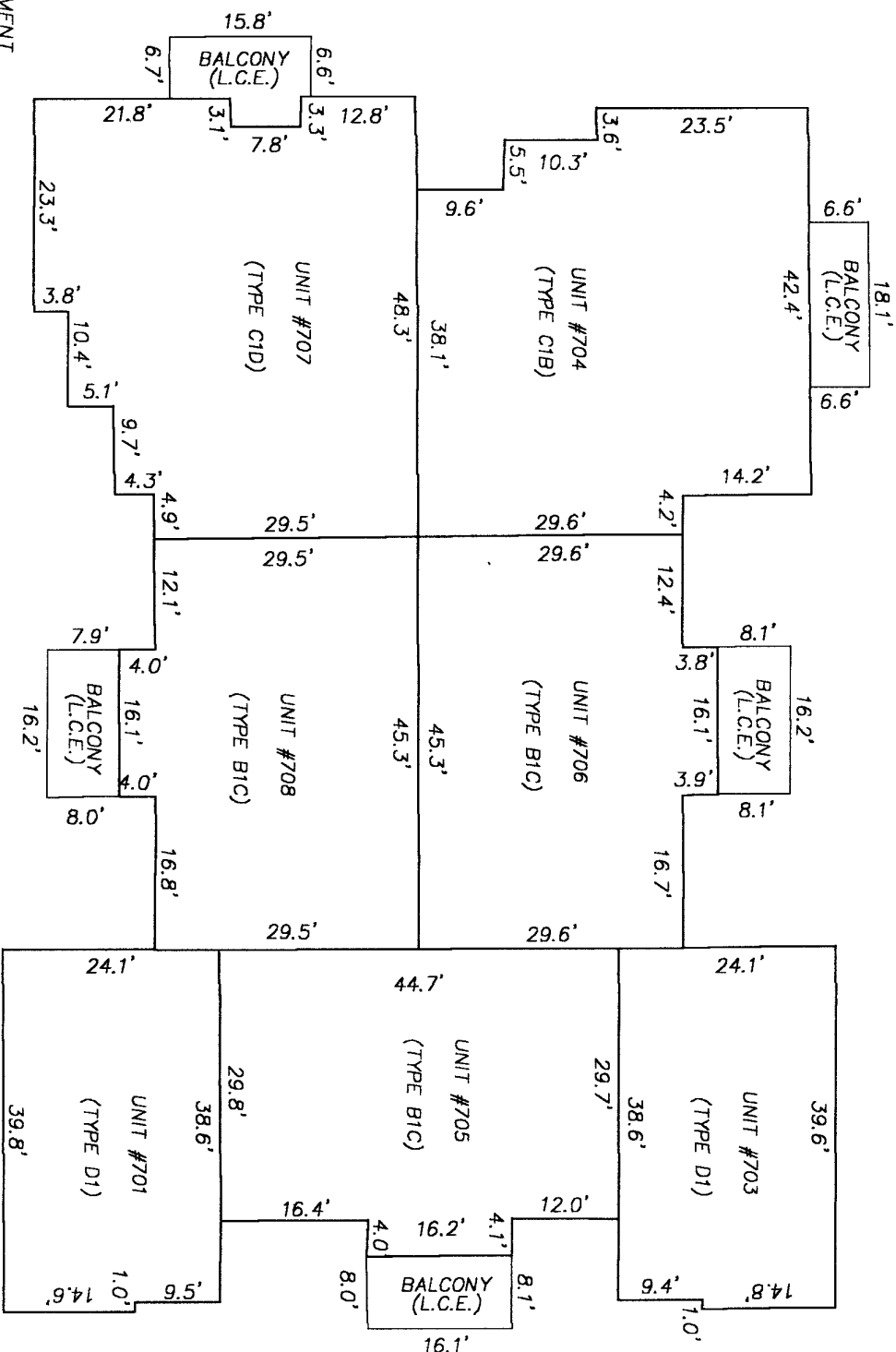
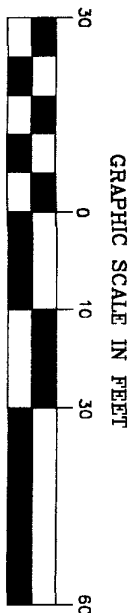

L.C.E.=LIMITED COMMON ELEMENT

RICHARD A. MILLER & ASSOCIATES
PROFESSIONAL LAND SURVEYORS
6701 BEACH BLVD. SUITE 100
JACKSONVILLE, FLORIDA 32225
(904) 721-5758 (FAX)
(904) 721-1226 (TEL)

BUILDING 700 PLOT PLAN
SECOND FLOOR

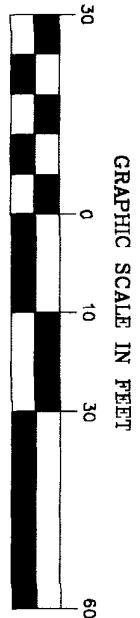
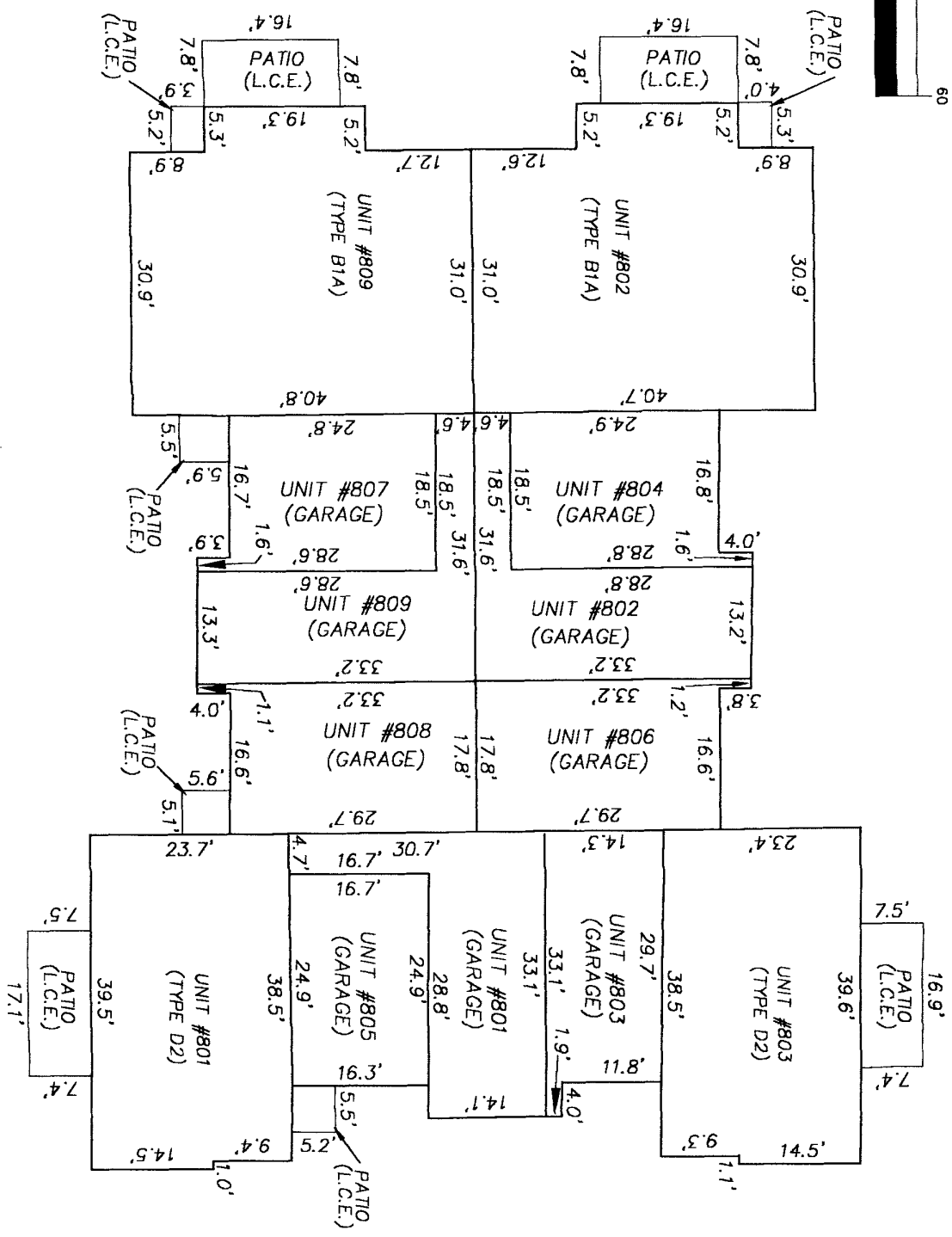

EXHIBIT "B"
HERITAGE DEERWOOD, A CONDOMINIUM



L.C.E.=LIMITED COMMON ELEMENT

BUILDING 800 PLOT PLAN
FIRST FLOOR

RICHARD A. MILLER & ASSOCIATES
 PROFESSIONAL LAND SURVEYORS
 6701 BEACH BLVD. SUITE 100
 JACKSONVILLE, FLORIDA 32225
 (904) 721-5758 (FAX)
 (904) 721-1226 (TEL)

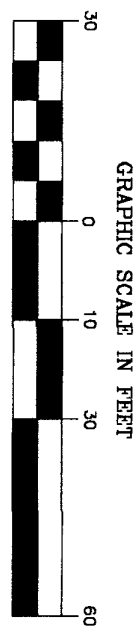
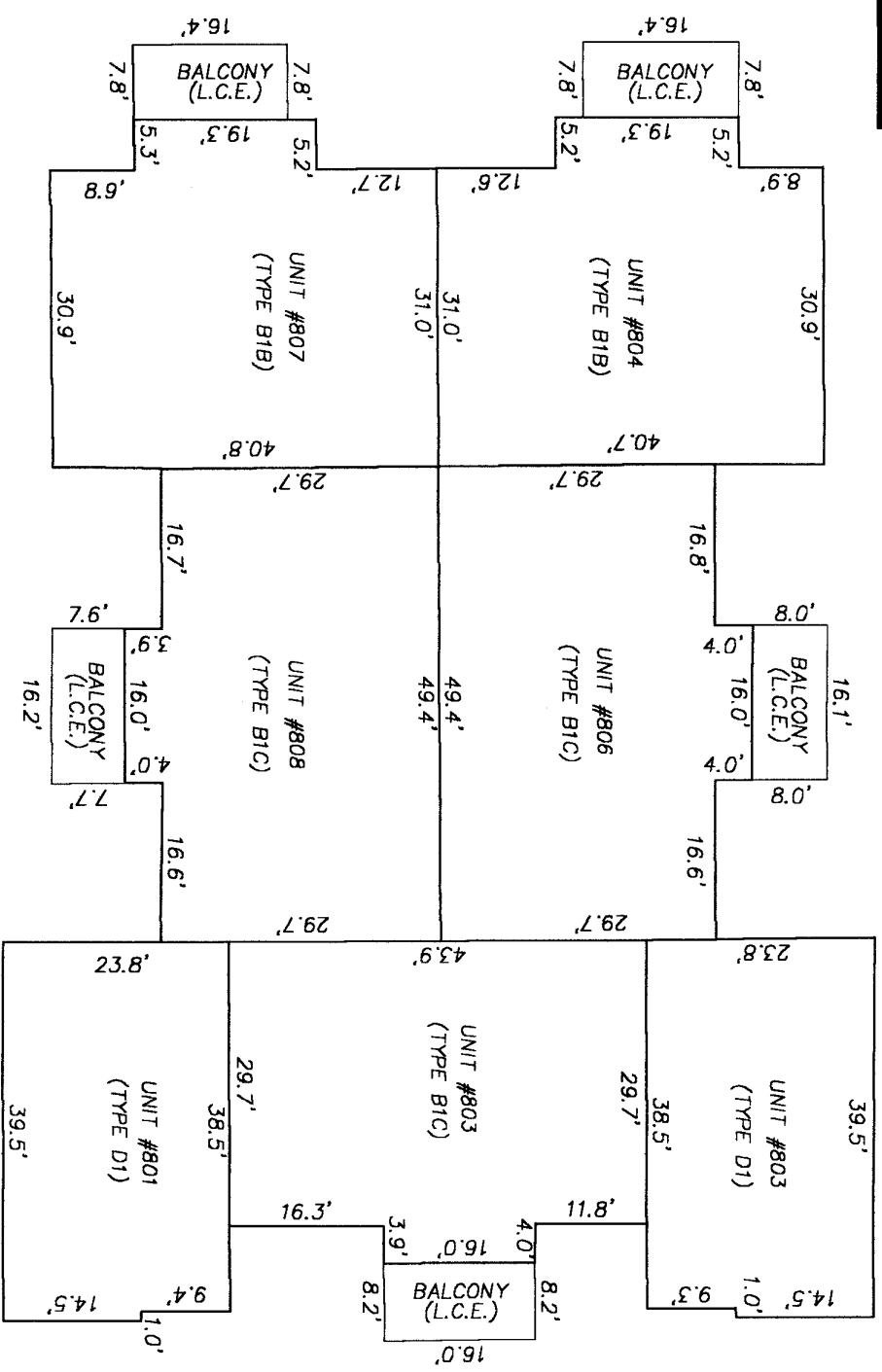

EXHIBIT "B" HERITAGE DEERWOOD, A CONDOMINIUM



L.C.E.=LIMITED COMMON ELEMENT

RICHARD A. MILLER & ASSOCIATES
 PROFESSIONAL LAND SURVEYORS
 6701 BEACH BLVD. SUITE 100
 JACKSONVILLE, FLORIDA 32225
 (904) 721-5758 (FAX)
 (904) 721-1226 (TEL)

BUILDING 800 PLOT PLAN SECOND FLOOR

EXHIBIT "B" HERITAGE DEERWOOD, A CONDOMINIUM

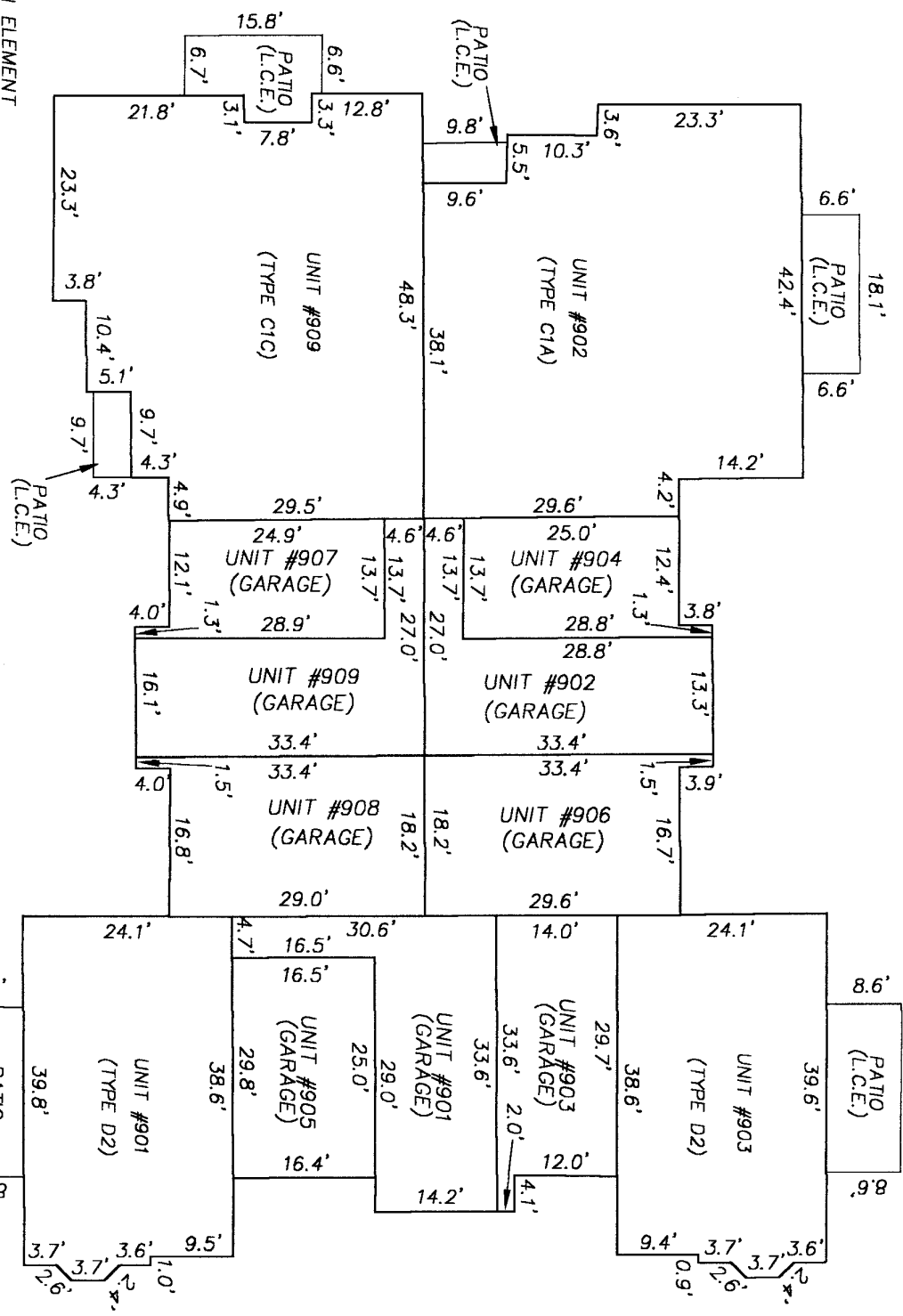

L.C.E.=LIMITED COMMON ELEMENT

RICHARD A. MILLER & ASSOCIATES
 PROFESSIONAL LAND SURVEYORS
 6701 BEACH BLVD, SUITE 100
 JACKSONVILLE, FLORIDA 32225
 (904) 721-5758 (FAX)
 (904) 721-1226 (TEL)

BUILDING 900 PLOT PLAN FIRST FLOOR

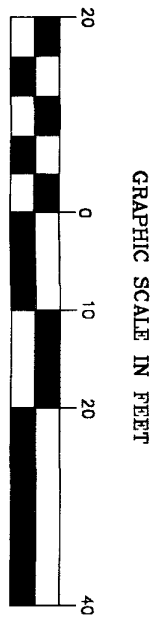
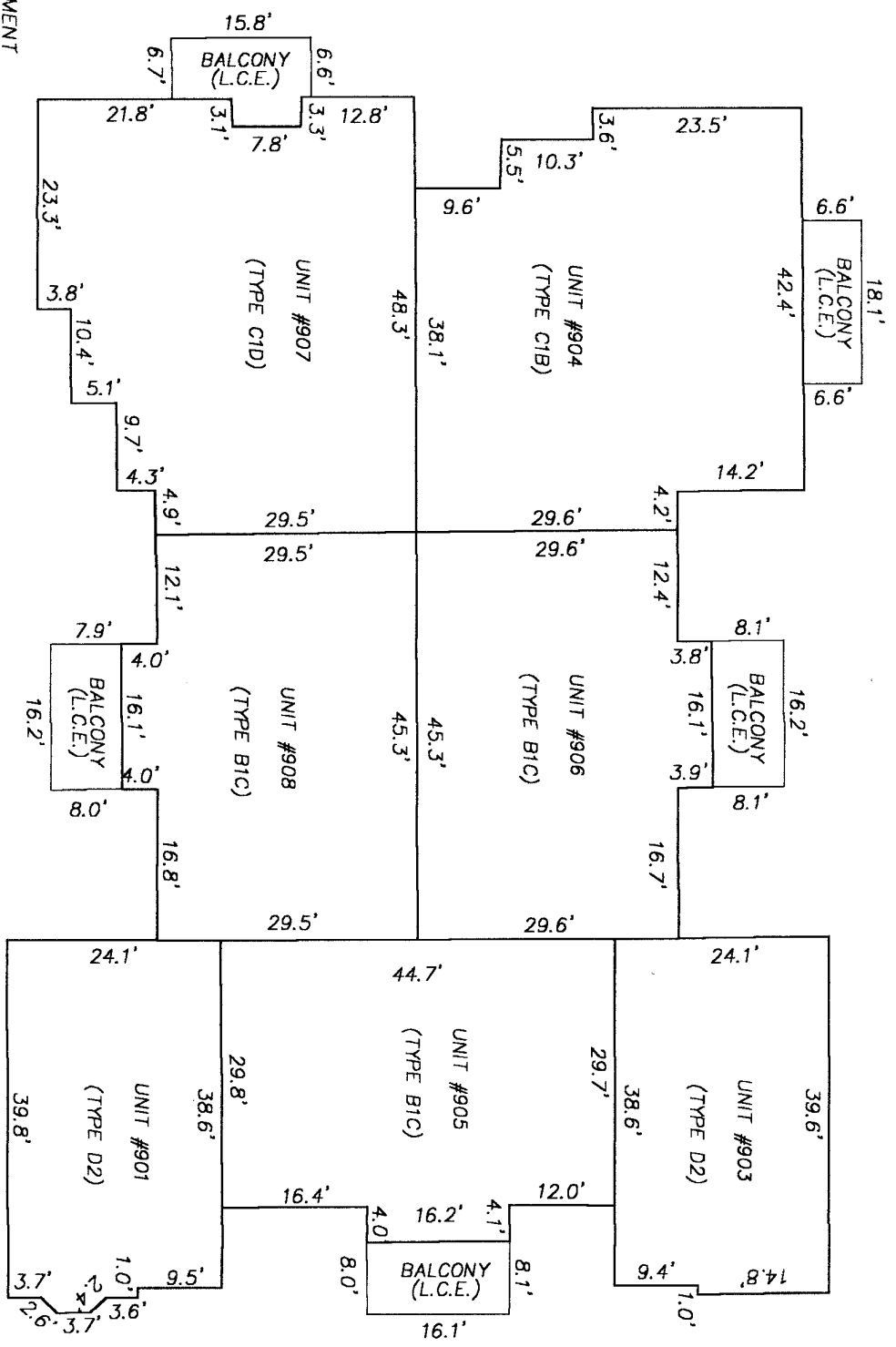
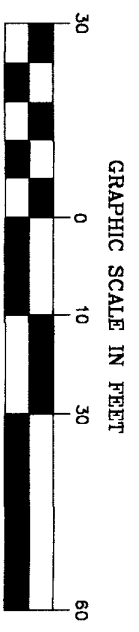

EXHIBIT "B" HERITAGE DEERWOOD, A CONDOMINIUM



L.C.E.=LIMITED COMMON ELEMENT

RICHARD A. MILLER & ASSOCIATES
PROFESSIONAL LAND SURVEYORS
6701 BEACH BLVD, SUITE 100
JACKSONVILLE, FLORIDA 32225
(904) 721-5758 (FAX)
(904) 721-1226 (TEL)

BUILDING 900 PLOT PLAN SECOND FLOOR

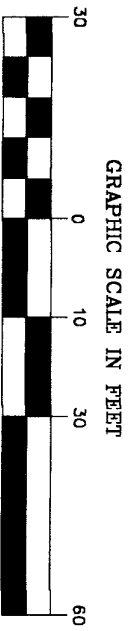

GRAPHIC SCALE IN FEET

EXHIBIT "B" HERITAGE DEERWOOD, A CONDOMINIUM

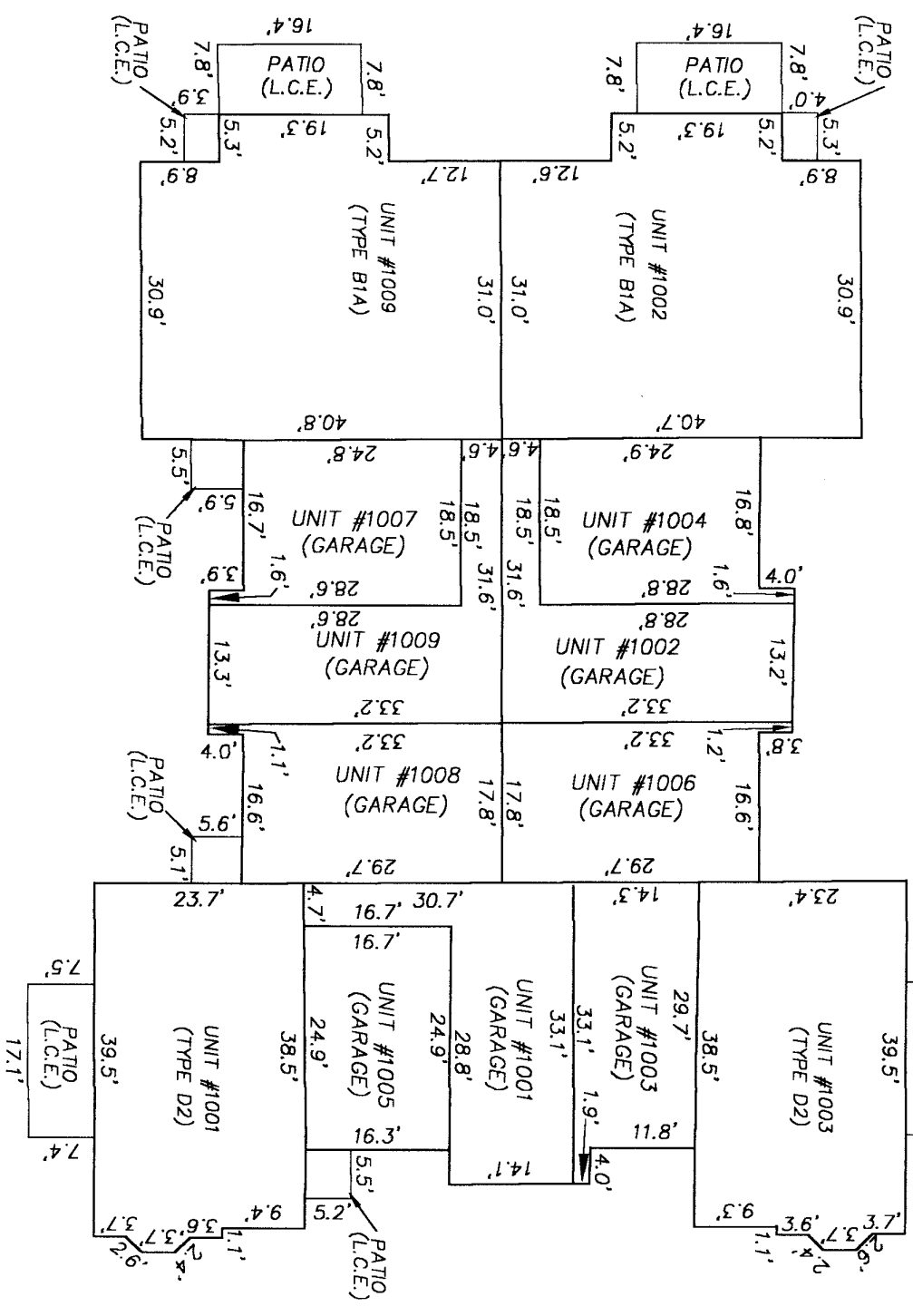

L.C.E. = LIMITED COMMON ELEMENT

BUILDING 1000 PLOT PLAN FIRST FLOOR

RICHARD A. MILLER & ASSOCIATES
PROFESSIONAL LAND SURVEYORS
6701 BEACH BLVD. SUITE 100
JACKSONVILLE, FLORIDA 32225
(904) 721-5758 (FAX)
(904) 721-1226 (TEL)

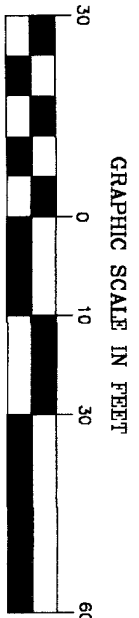
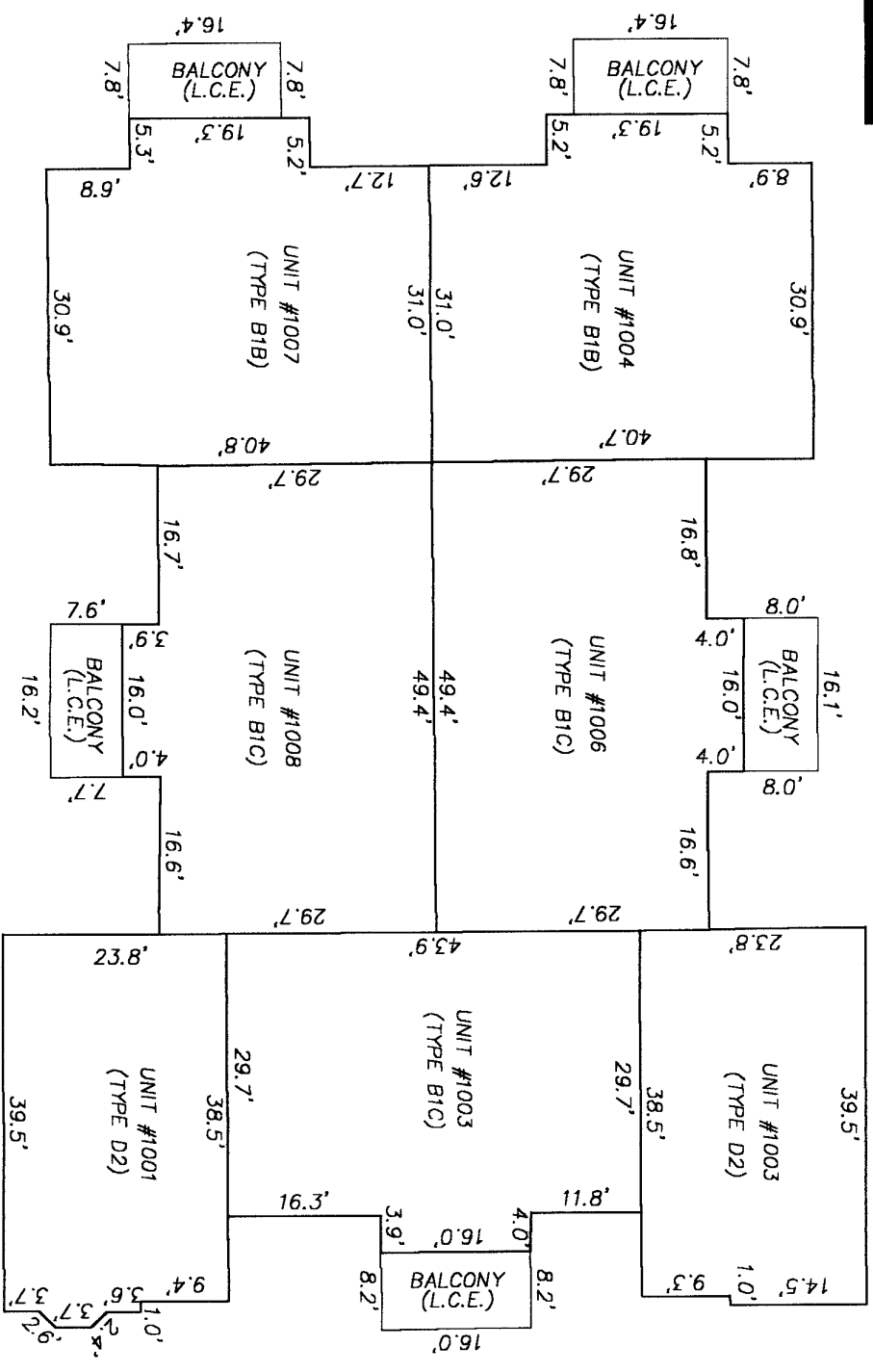

EXHIBIT "B" HERITAGE DEERWOOD, A CONDOMINIUM



L.C.E.=LIMITED COMMON ELEMENT

BUILDING 1000 PLOT PLAN SECOND FLOOR

RICHARD A. MILLER & ASSOCIATES
 PROFESSIONAL LAND SURVEYORS
 6701 BEACH BLVD, SUITE 100
 JACKSONVILLE, FLORIDA 32225
 (904) 721-5758 (FAX)
 (904) 721-1226 (TEL)

AUGUST 25, 2005

SHEET: 51 OF 86

EXHIBIT "B" HERITAGE DEERWOOD, A CONDOMINIUM

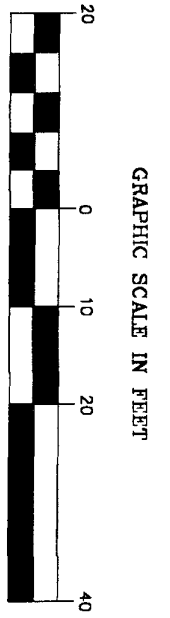
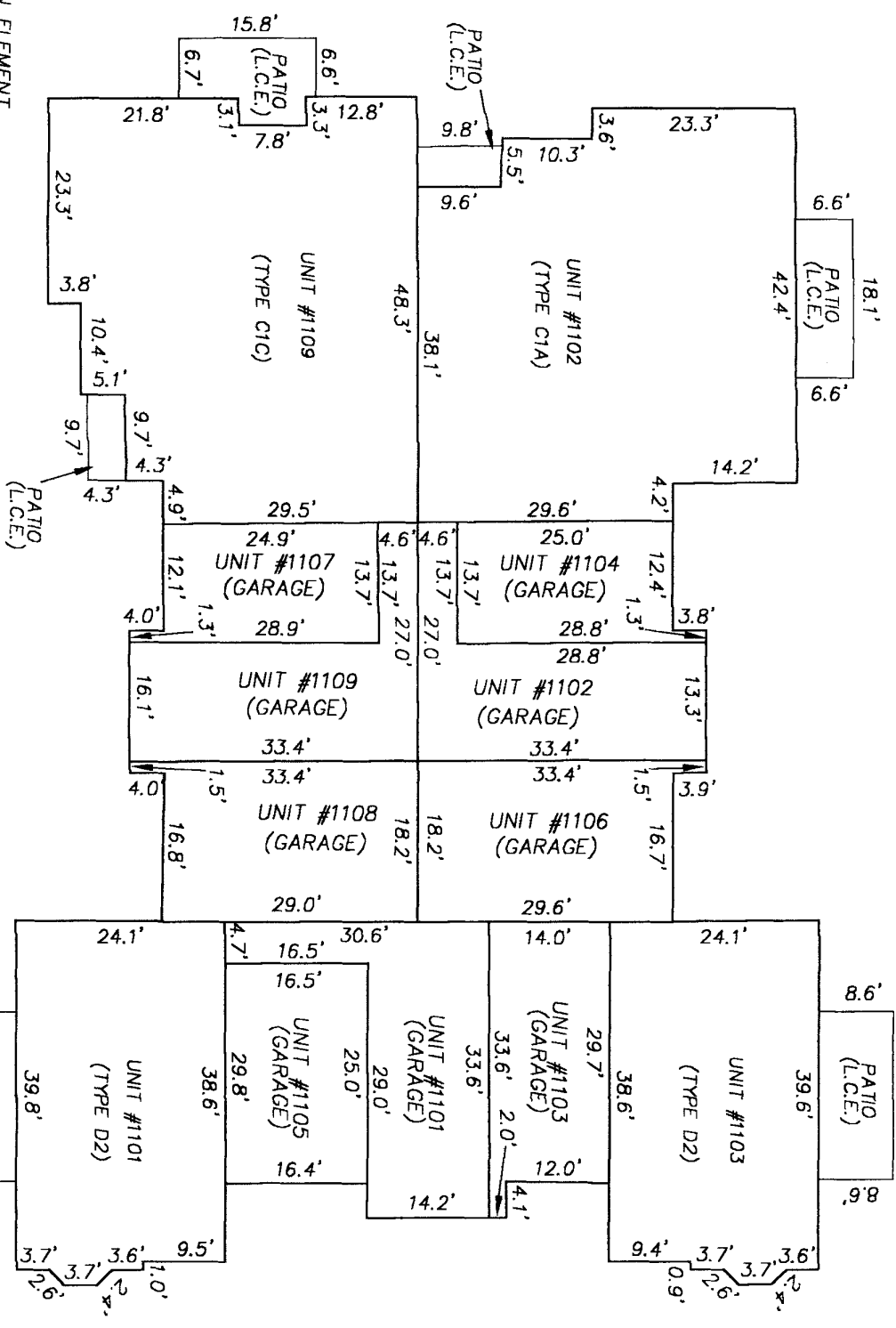

L.C.E.=LIMITED COMMON ELEMENT

BUILDING 1100 PLOT PLAN FIRST FLOOR

RICHARD A. MILLER & ASSOCIATES
 PROFESSIONAL LAND SURVEYORS
 6701 BEACH BLVD., SUITE 100
 JACKSONVILLE, FLORIDA 32225
 (904) 721-5758 (FAX)
 (904) 721-1226 (TEL)

EXHIBIT "B" HERITAGE DEERWOOD, A CONDOMINIUM

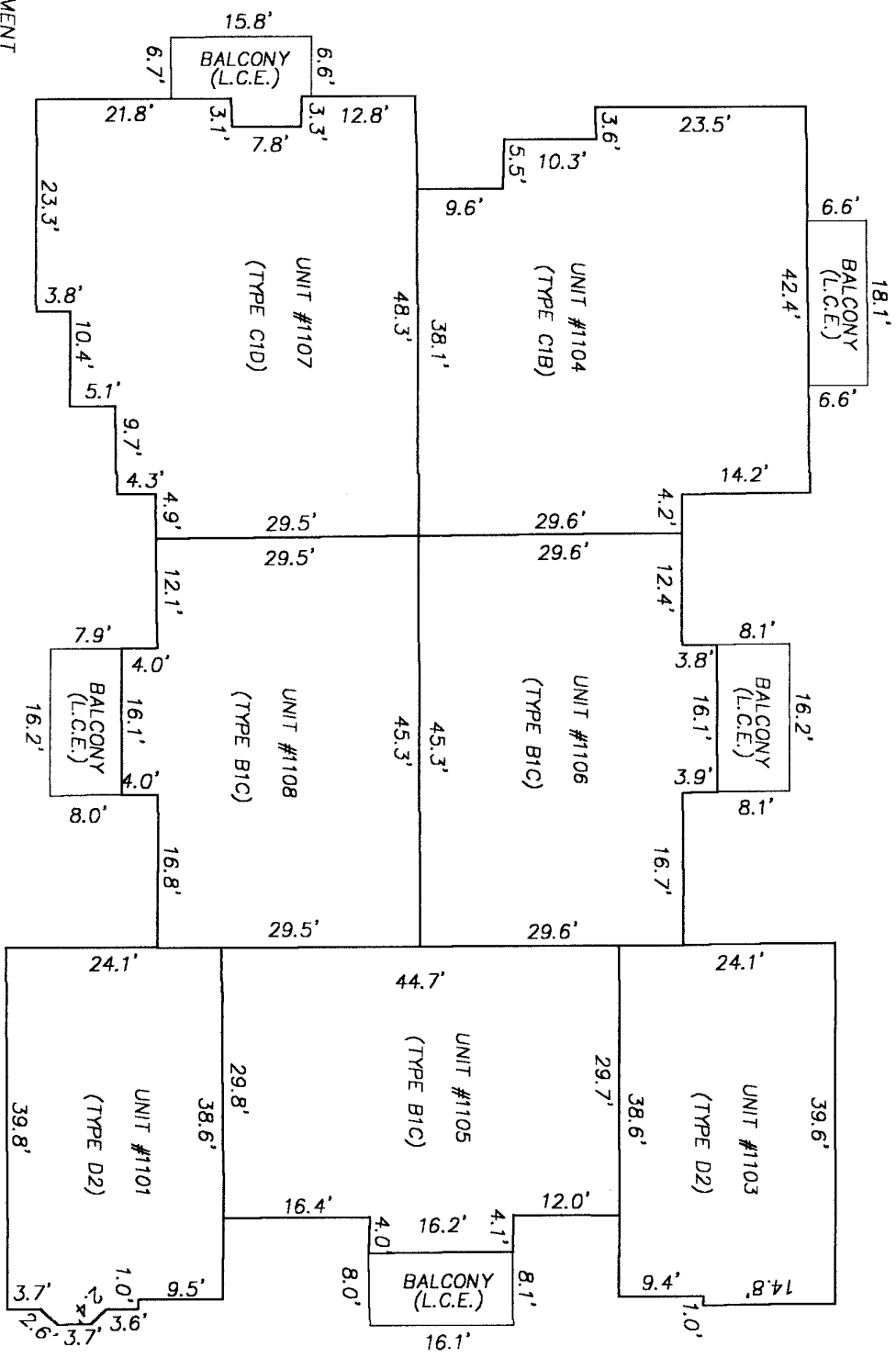
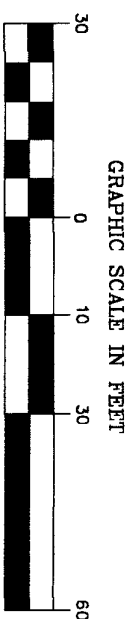

L.C.E.=LIMITED COMMON ELEMENT

RICHARD A. MILLER & ASSOCIATES
 PROFESSIONAL LAND SURVEYORS
 6701 BEACH BLVD. SUITE 100
 JACKSONVILLE, FLORIDA 32225
 (904) 721-5758 (FAX)
 (904) 721-1226 (TEL)

BUILDING 1100 PLOT PLAN SECOND FLOOR

EXHIBIT "B" HERITAGE DEERWOOD, A CONDOMINIUM

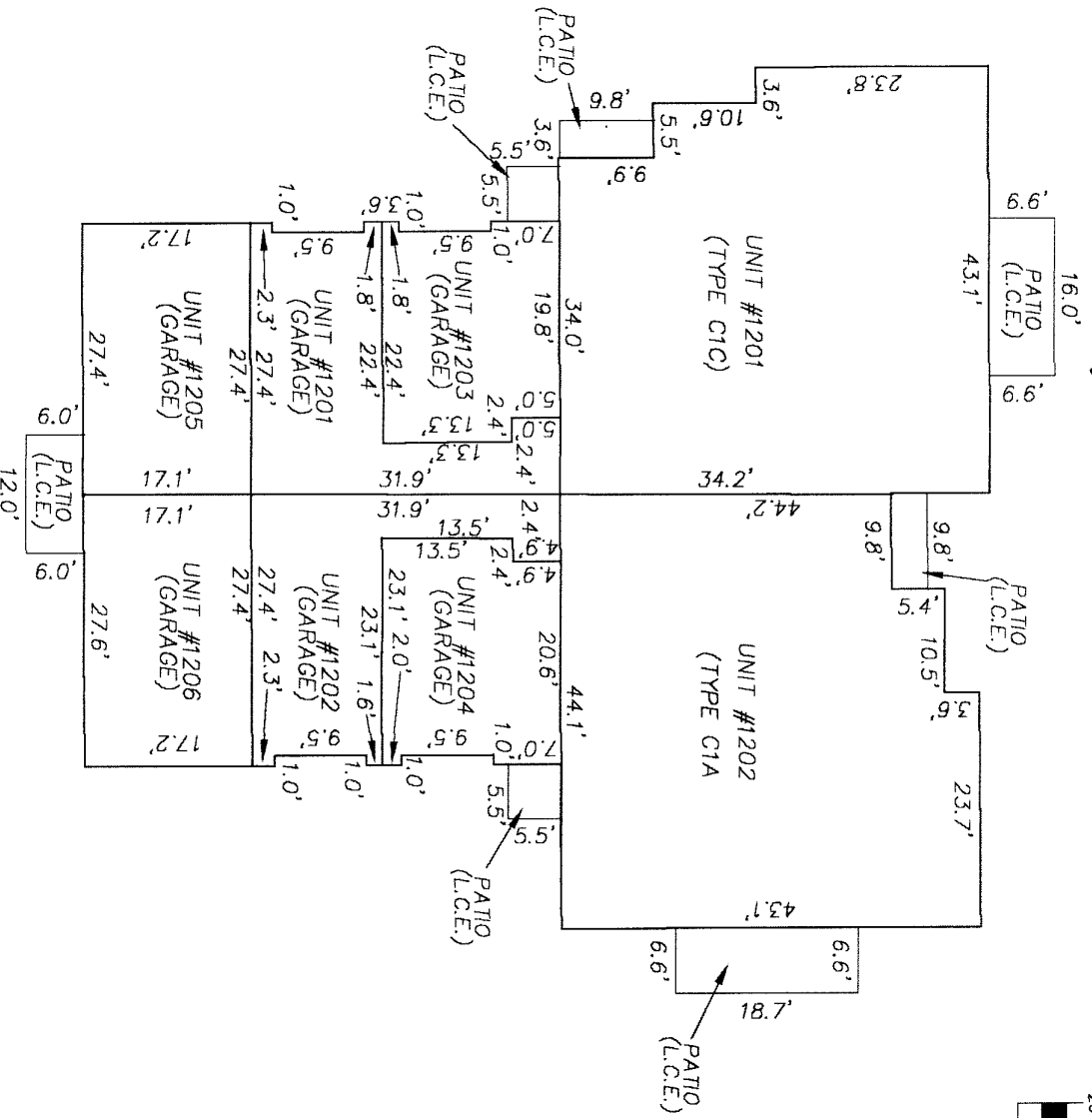

L.C.E.=LIMITED COMMON ELEMENT

RICHARD A. MILLER & ASSOCIATES
 PROFESSIONAL LAND SURVEYORS
 6701 BEACH BLVD., SUITE 100
 JACKSONVILLE, FLORIDA 32225
 (904) 721-5758 (FAX)
 (904) 721-1226 (TEL)

BUILDING 1200 PLOT PLAN FIRST FLOOR

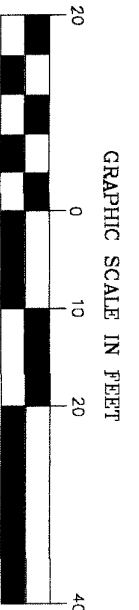
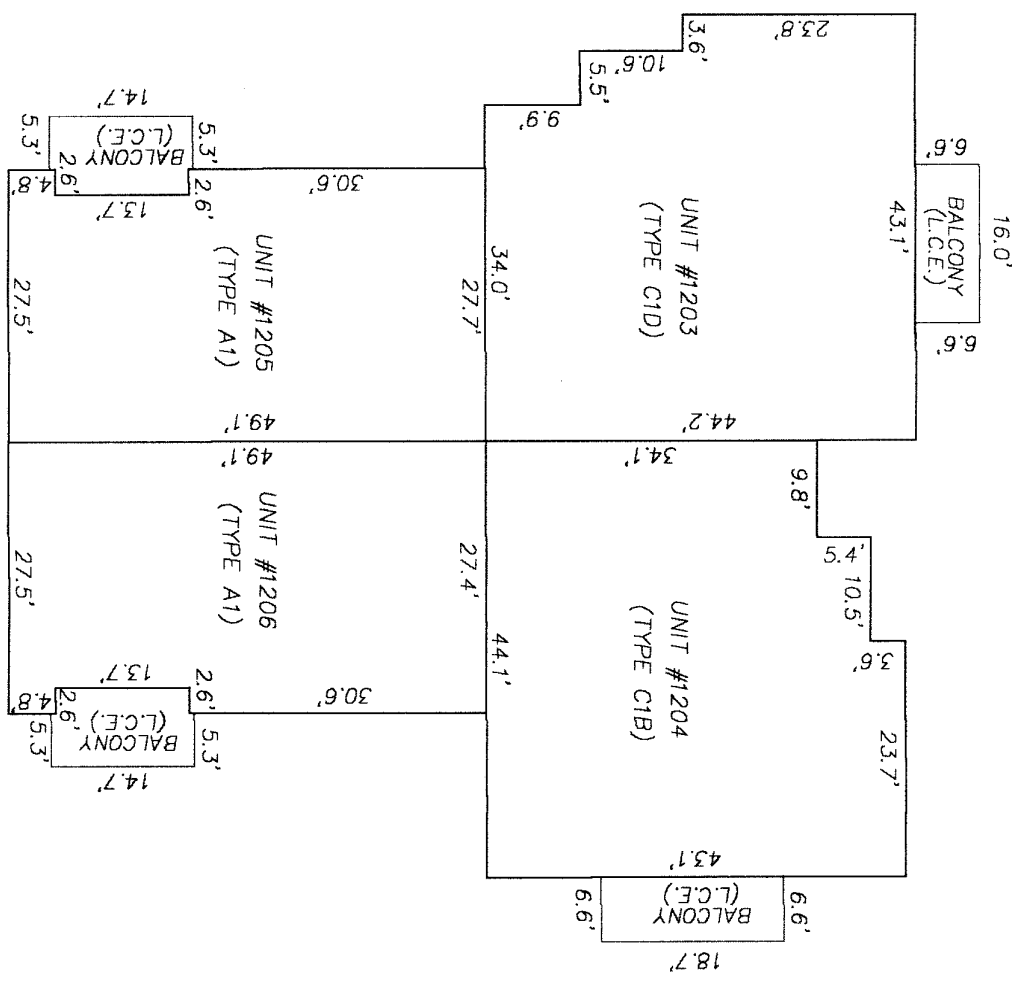
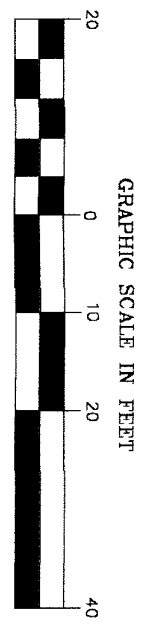

EXHIBIT "B" HERITAGE DEERWOOD, A CONDOMINIUM



L.C.E.=LIMITED COMMON ELEMENT

RICHARD A. MILLER & ASSOCIATES
 PROFESSIONAL LAND SURVEYORS
 6701 BEACH BLVD. SUITE 100
 JACKSONVILLE, FLORIDA 32225
 (904) 721-5758 (FAX)
 (904) 721-1226 (TEL)

BUILDING 1200 PLOT PLAN SECOND FLOOR

EXHIBIT "B" HERITAGE DEERWOOD, A CONDOMINIUM

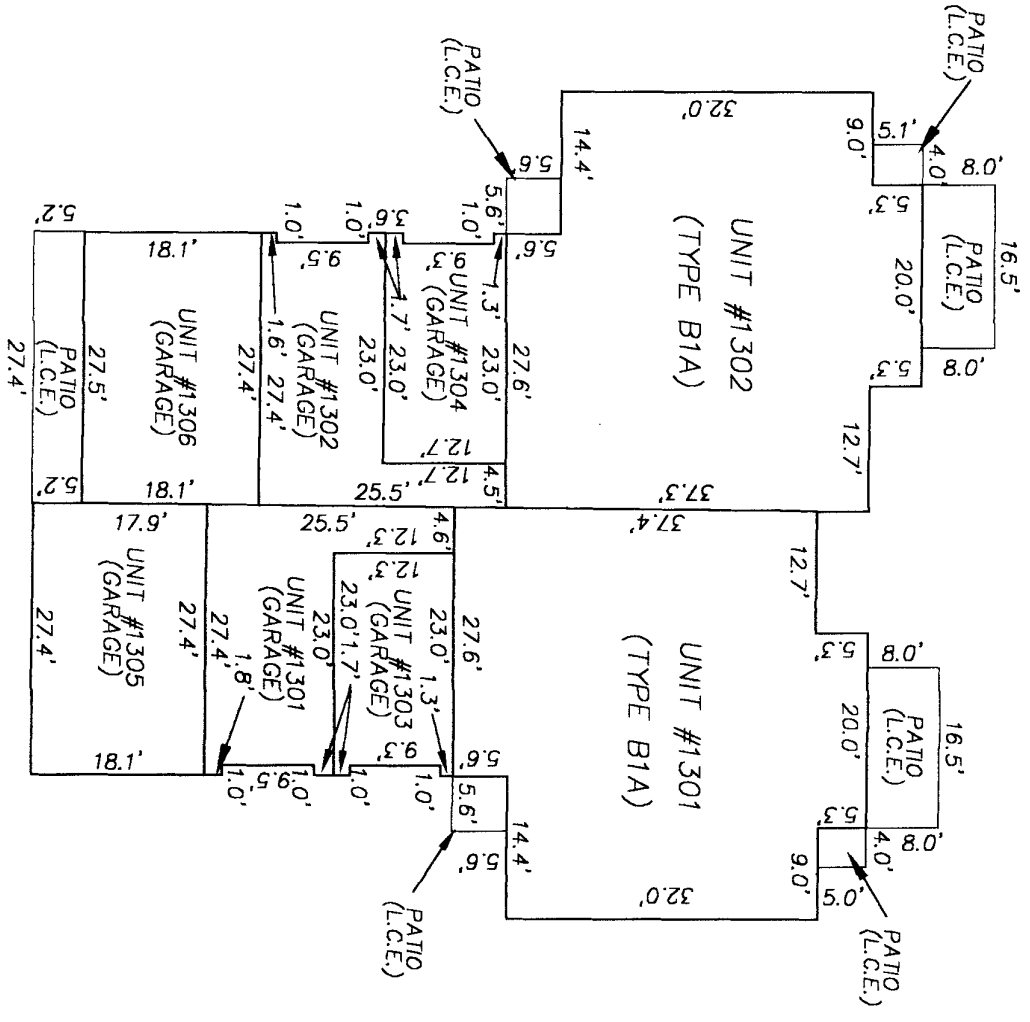
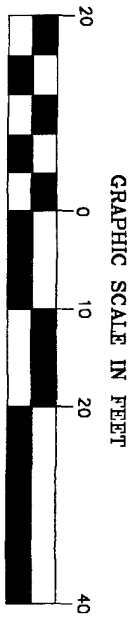

L.C.E.=LIMITED COMMON ELEMENT

BUILDING 1300 PLOT PLAN FIRST FLOOR

RICHARD A. MILLER & ASSOCIATES
 PROFESSIONAL LAND SURVEYORS
 6701 BEACH BLVD. SUITE 100
 JACKSONVILLE, FLORIDA 32225
 (904) 721-5758 (FAX)
 (904) 721-1226 (TEL)

AUGUST 25, 2005

SHEET: 56 OF 86

EXHIBIT "B" HERITAGE DEERWOOD, A CONDOMINIUM

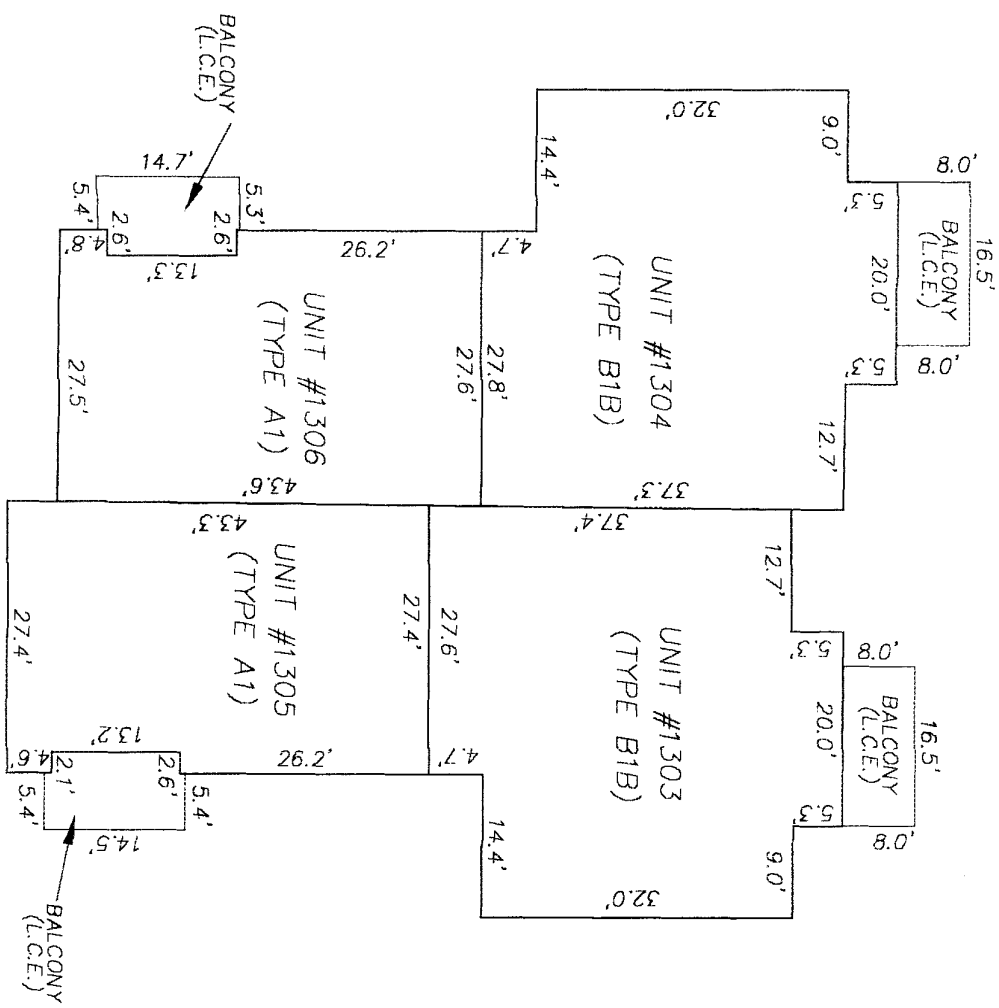
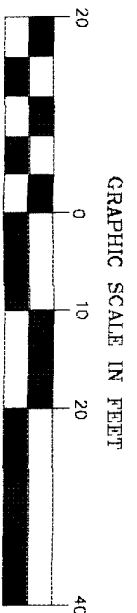

L.C.E.=LIMITED COMMON ELEMENT

BUILDING 1300 PLOT PLAN SECOND FLOOR

RICHARD A. MILLER & ASSOCIATES
 PROFESSIONAL LAND SURVEYORS
 6701 BEACH BLVD. SUITE 100
 JACKSONVILLE, FLORIDA 32225
 (904) 721-5758 (FAX)
 (904) 721-1226 (TEL)

EXHIBIT "B"

HERITAGE DEERWOOD, A CONDOMINIUM

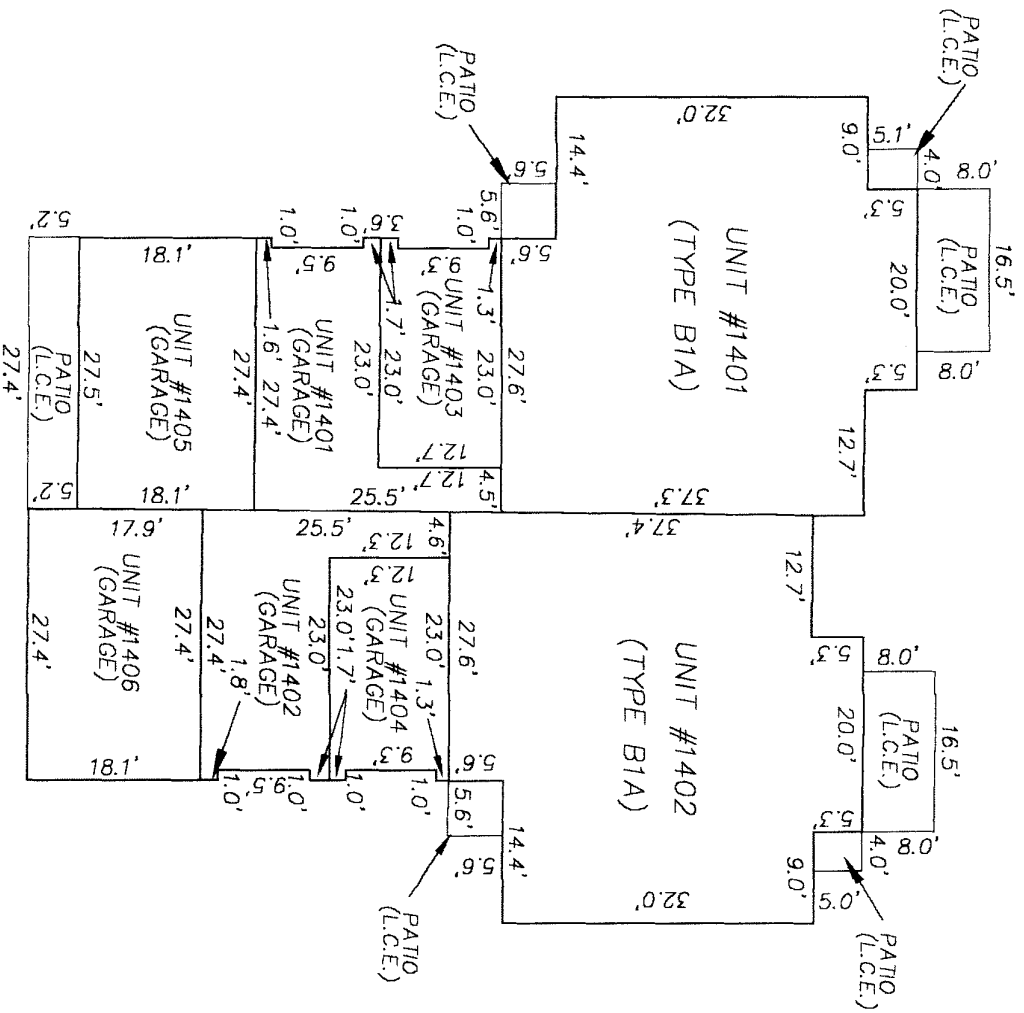

L.C.E.=LIMITED COMMON ELEMENT

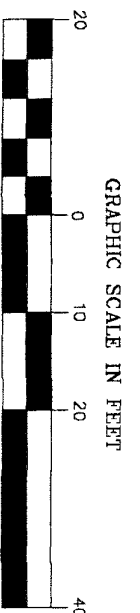

BUILDING 1400 PLOT PLAN FIRST FLOOR

RICHARD A. MILLER & ASSOCIATES
 PROFESSIONAL LAND SURVEYORS
 6701 BEACH BLVD. SUITE 100
 JACKSONVILLE, FLORIDA 32225
 (904) 721-5758 (FAX)
 (904) 721-1226 (TEL)

AUGUST 25, 2005

SHEET: 58 OF 86

EXHIBIT "B" HERITAGE DEERWOOD, A CONDOMINIUM

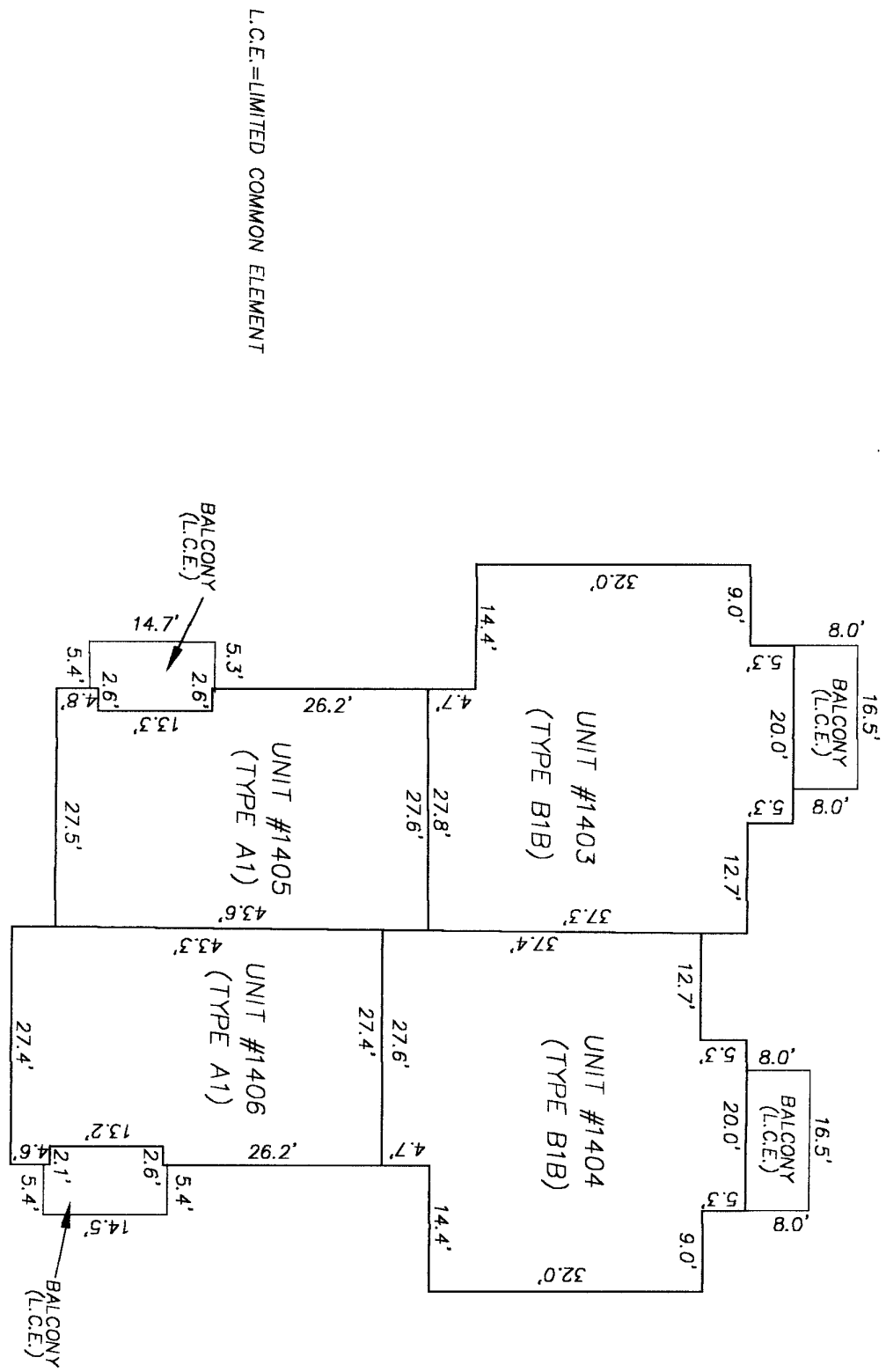
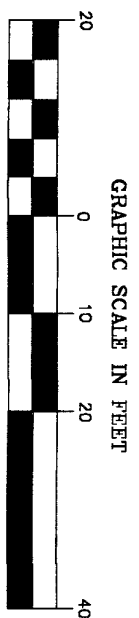

BUILDING 1400 PLOT PLAN SECOND FLOOR

RICHARD A. MILLER & ASSOCIATES
 PROFESSIONAL LAND SURVEYORS
 6701 BEACH BLVD. SUITE 100
 JACKSONVILLE, FLORIDA 32225
 (904) 721-5758 (FAX)
 (904) 721-1226 (TEL)

AUGUST 25, 2005

SHEET: 59 OF 86

EXHIBIT "B" HERITAGE DEERWOOD, A CONDOMINIUM

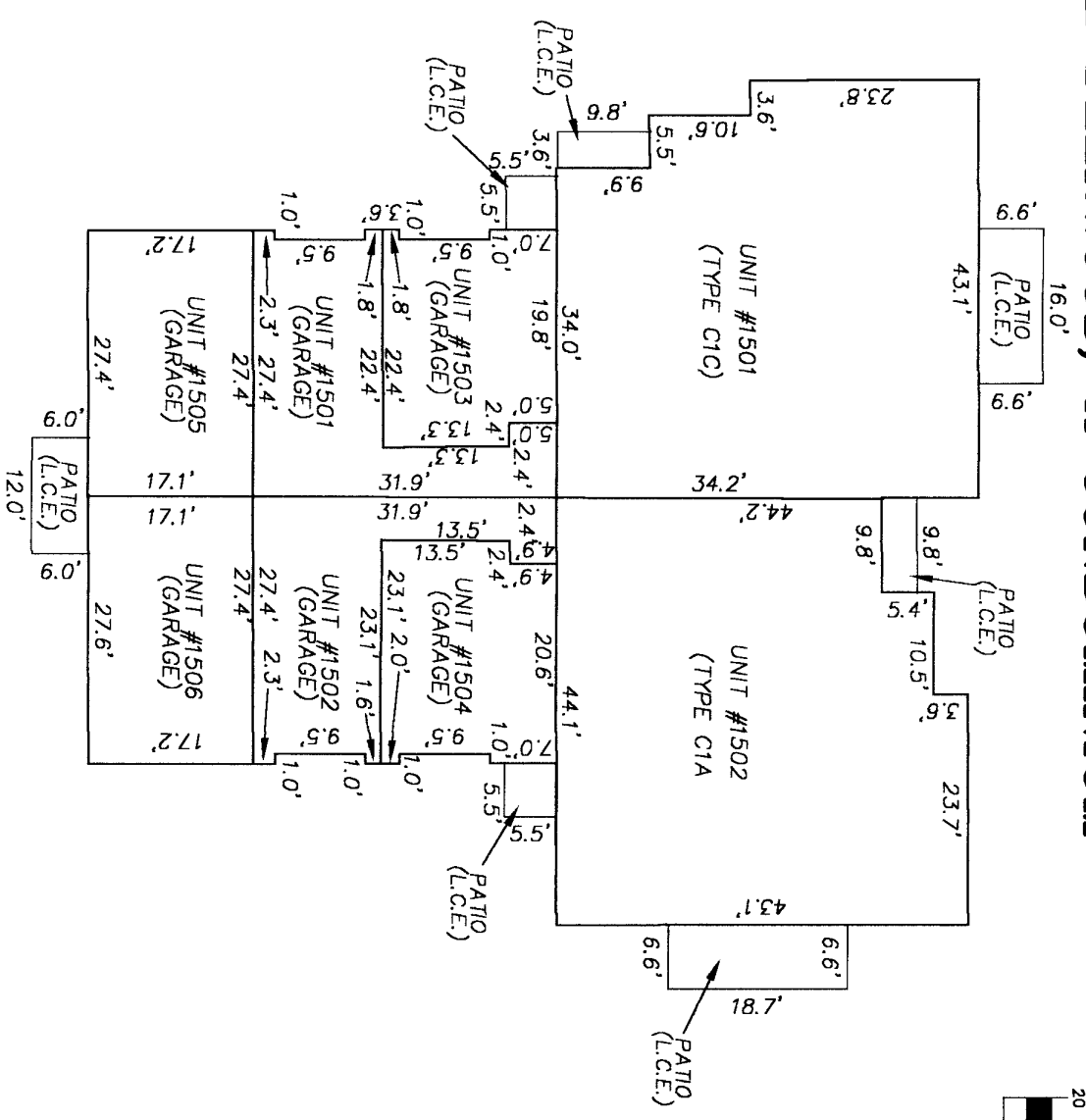

L.C.E.=LIMITED COMMON ELEMENT

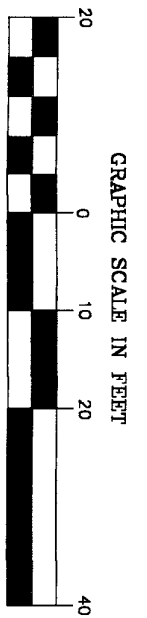

BUILDING 1500 PLOT PLAN FIRST FLOOR

RICHARD A. MILLER & ASSOCIATES
 PROFESSIONAL LAND SURVEYORS
 6701 BEACH BLVD. SUITE 100
 JACKSONVILLE, FLORIDA 32225
 (904) 721-5758 (FAX)
 (904) 721-1226 (TEL)

EXHIBIT "B"

HERITAGE DEERWOOD, A CONDOMINIUM

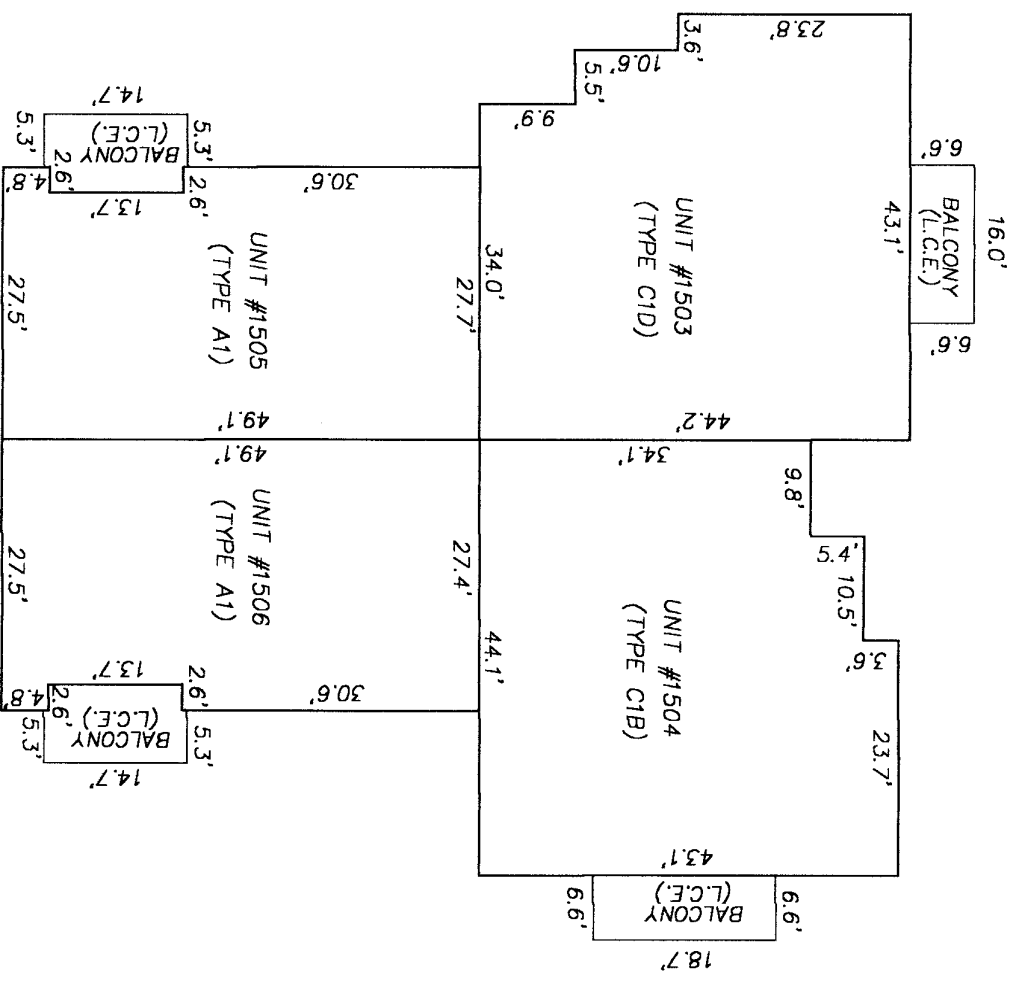

L.C.E.=LIMITED COMMON ELEMENT

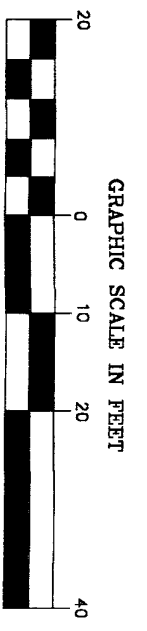

RICHARD A. MILLER & ASSOCIATES
 PROFESSIONAL LAND SURVEYORS
 6701 BEACH BLVD. SUITE 100
 JACKSONVILLE, FLORIDA 32225
 (904) 721-5758 (FAX)
 (904) 721-1226 (TEL)

BUILDING 1500 PLOT PLAN SECOND FLOOR

AUGUST 25, 2005

SHEET: 61 OF 86

EXHIBIT "B" HERITAGE DEERWOOD, A CONDOMINIUM

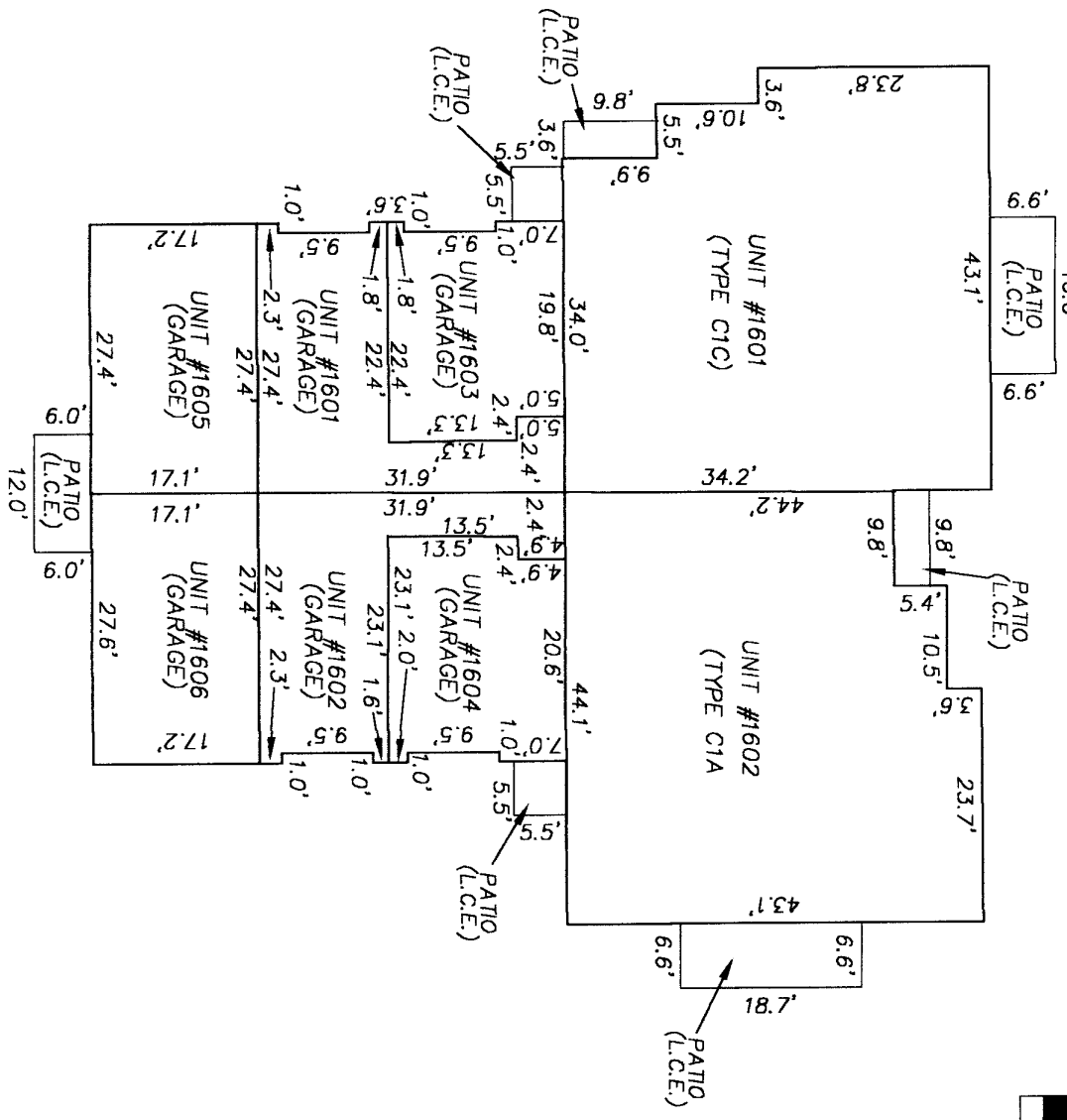
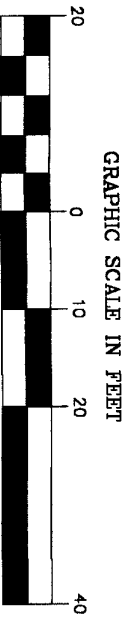

L.C.E.=LIMITED COMMON ELEMENT

BUILDING 1600 PLOT PLAN FIRST FLOOR

RICHARD A. MILLER & ASSOCIATES
 PROFESSIONAL LAND SURVEYORS
 6701 BEACH BLVD., SUITE 100
 JACKSONVILLE, FLORIDA 32225
 (904) 721-5758 (FAX)
 (904) 721-1226 (TEL)

EXHIBIT "B" HERITAGE DEERWOOD, A CONDOMINIUM

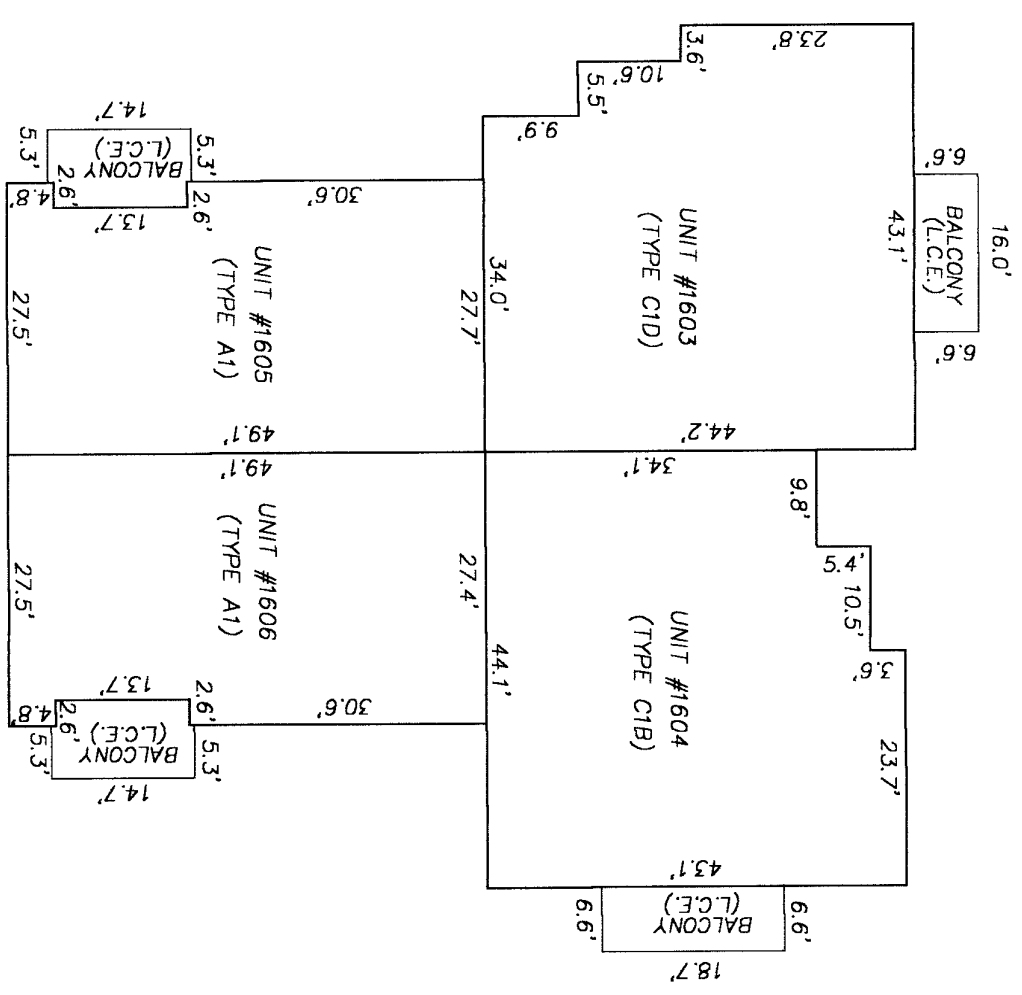
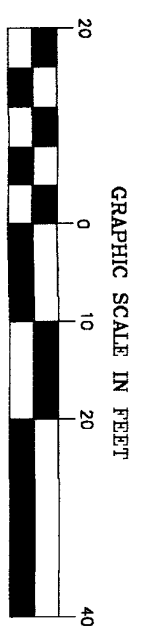

L.C.E.=LIMITED COMMON ELEMENT

RICHARD A. MILLER & ASSOCIATES
 PROFESSIONAL LAND SURVEYORS
 6701 BEACH BLVD. SUITE 100
 JACKSONVILLE, FLORIDA 32225
 (904) 721-5758 (FAX)
 (904) 721-1226 (TEL)

BUILDING 1600 PLOT PLAN SECOND FLOOR

AUGUST 25, 2005

SHEET: 63 OF 86

EXHIBIT "B" HERITAGE DEERWOOD, A CONDOMINIUM

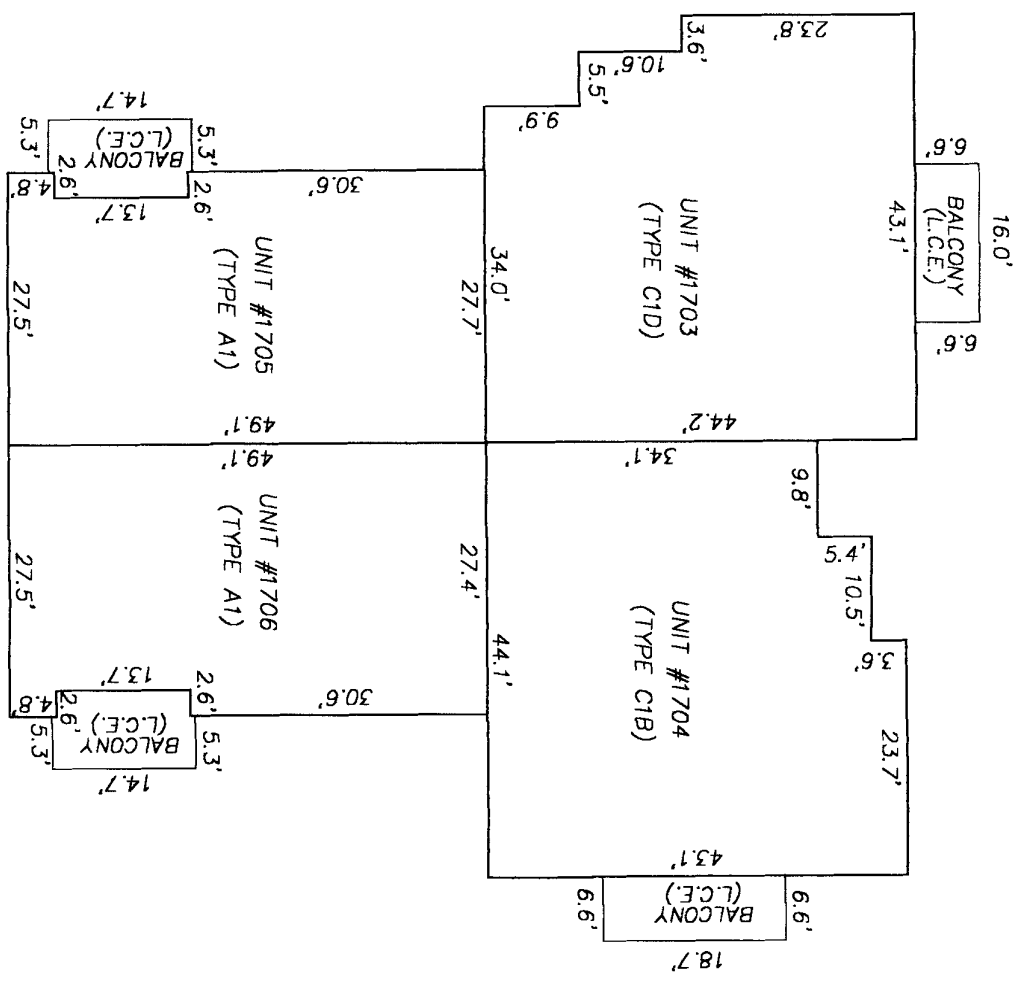
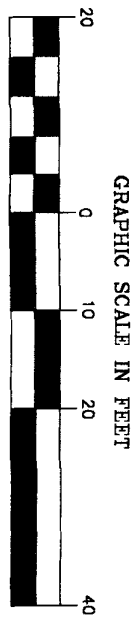

L.C.E.=LIMITED COMMON ELEMENT

RICHARD A. MILLER & ASSOCIATES
 PROFESSIONAL LAND SURVEYORS
 6701 BEACH BLVD., SUITE 100
 JACKSONVILLE, FLORIDA 32225
 (904) 721-5758 (FAX)
 (904) 721-1226 (TEL)

BUILDING 1700 PLOT PLAN SECOND FLOOR

AUGUST 25, 2005

SHEET: 65 OF 86

EXHIBIT "B" HERITAGE DEERWOOD, A CONDOMINIUM

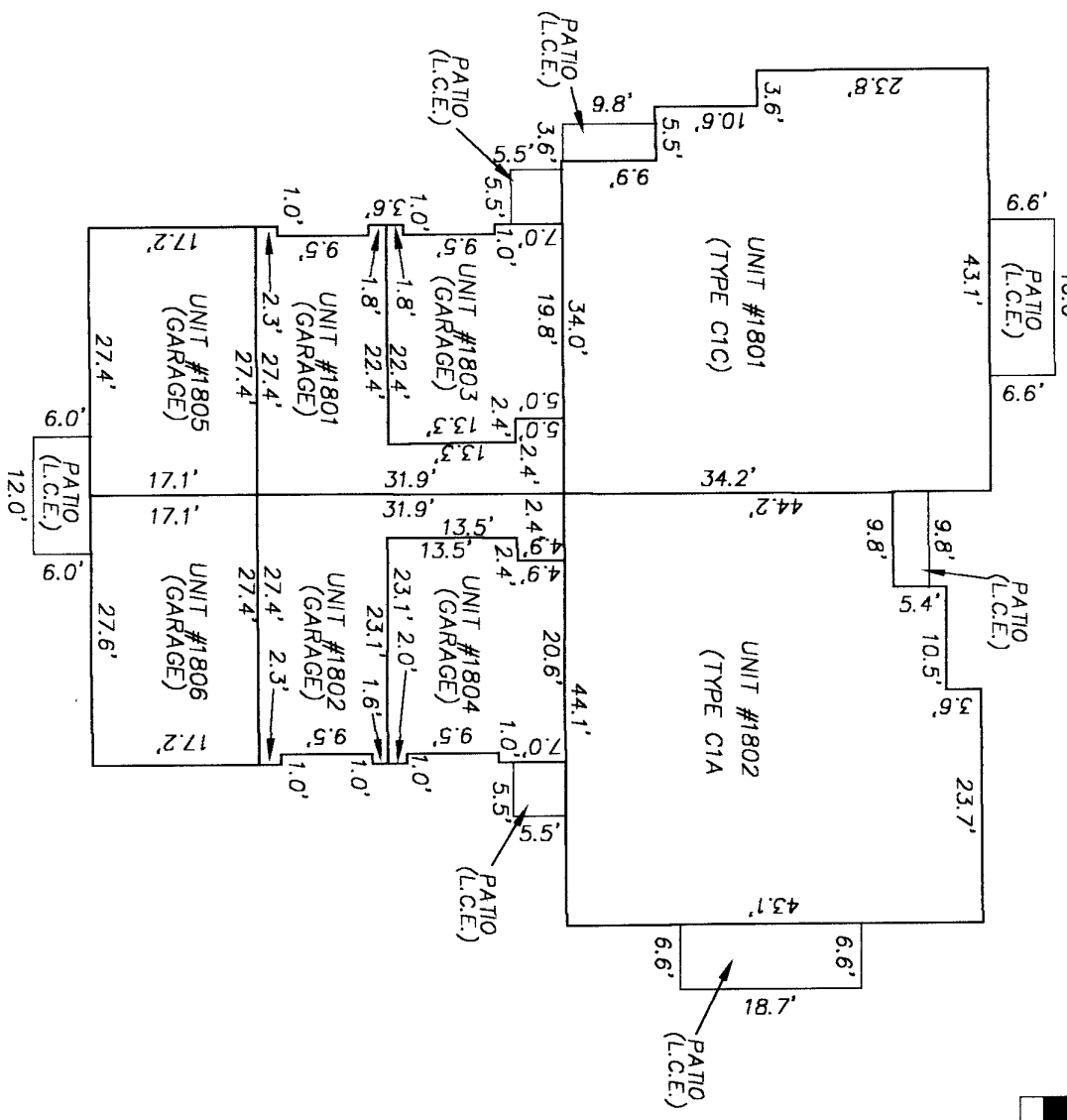

L.C.E.=LIMITED COMMON ELEMENT

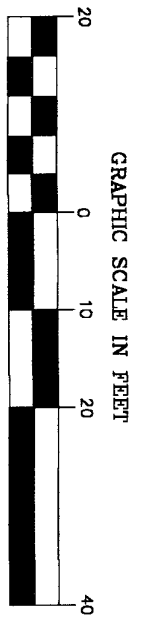

BUILDING 1800 PLOT PLAN FIRST FLOOR

RICHARD A. MILLER & ASSOCIATES
 PROFESSIONAL LAND SURVEYORS
 6701 BEACH BLVD., SUITE 100
 JACKSONVILLE, FLORIDA 32225
 (904) 721-5758 (FAX)
 (904) 721-1226 (TEL)

AUGUST 25, 2005

SHEET: 66 OF 86

EXHIBIT "B" HERITAGE DEERWOOD, A CONDOMINIUM

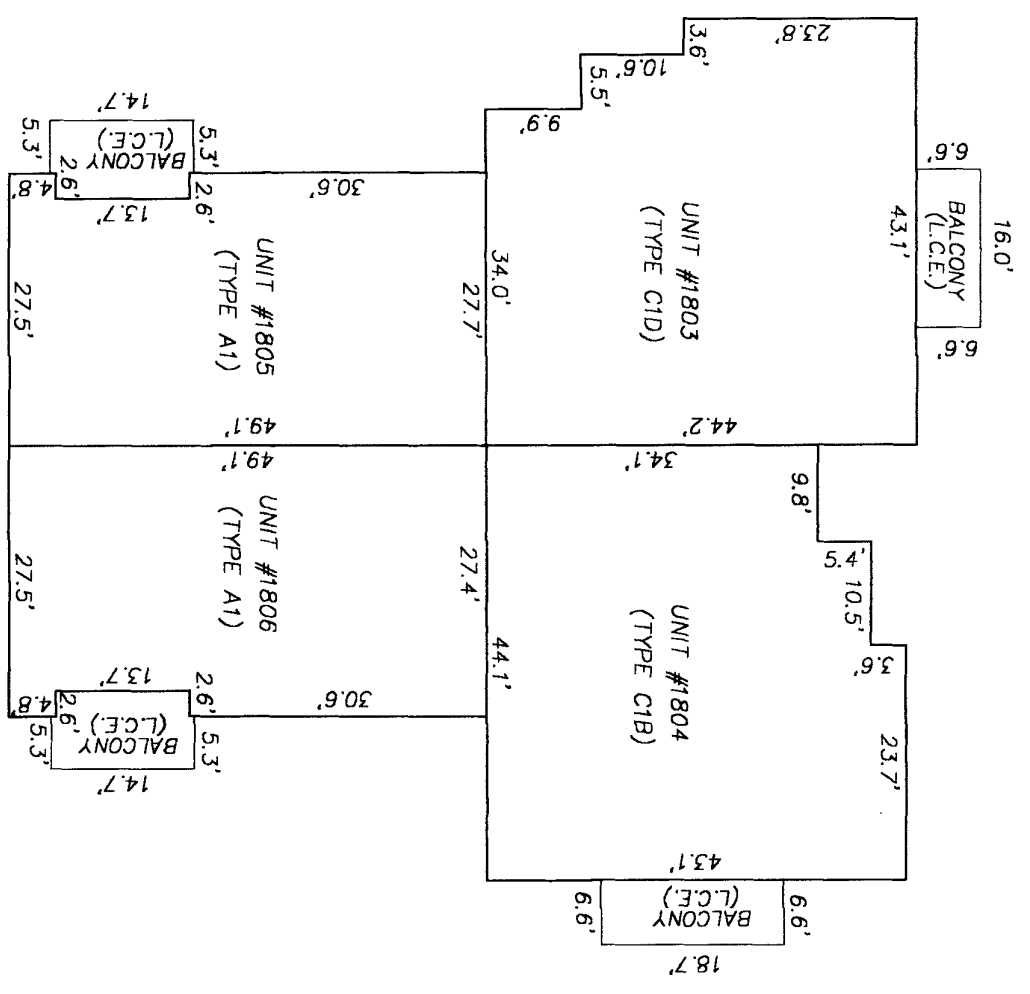
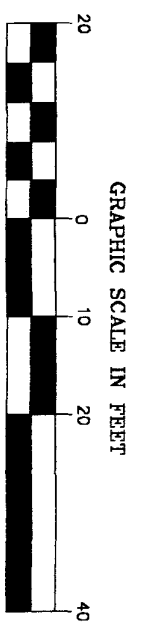

L.C.E.=LIMITED COMMON ELEMENT

RICHARD A. MILLER & ASSOCIATES
 PROFESSIONAL LAND SURVEYORS
 6701 BEACH BLVD, SUITE 100
 JACKSONVILLE, FLORIDA 32225
 (904) 721-5758 (FAX)
 (904) 721-1226 (TEL)

BUILDING 1800 PLOT PLAN SECOND FLOOR

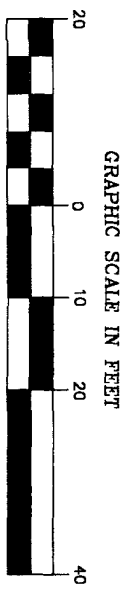
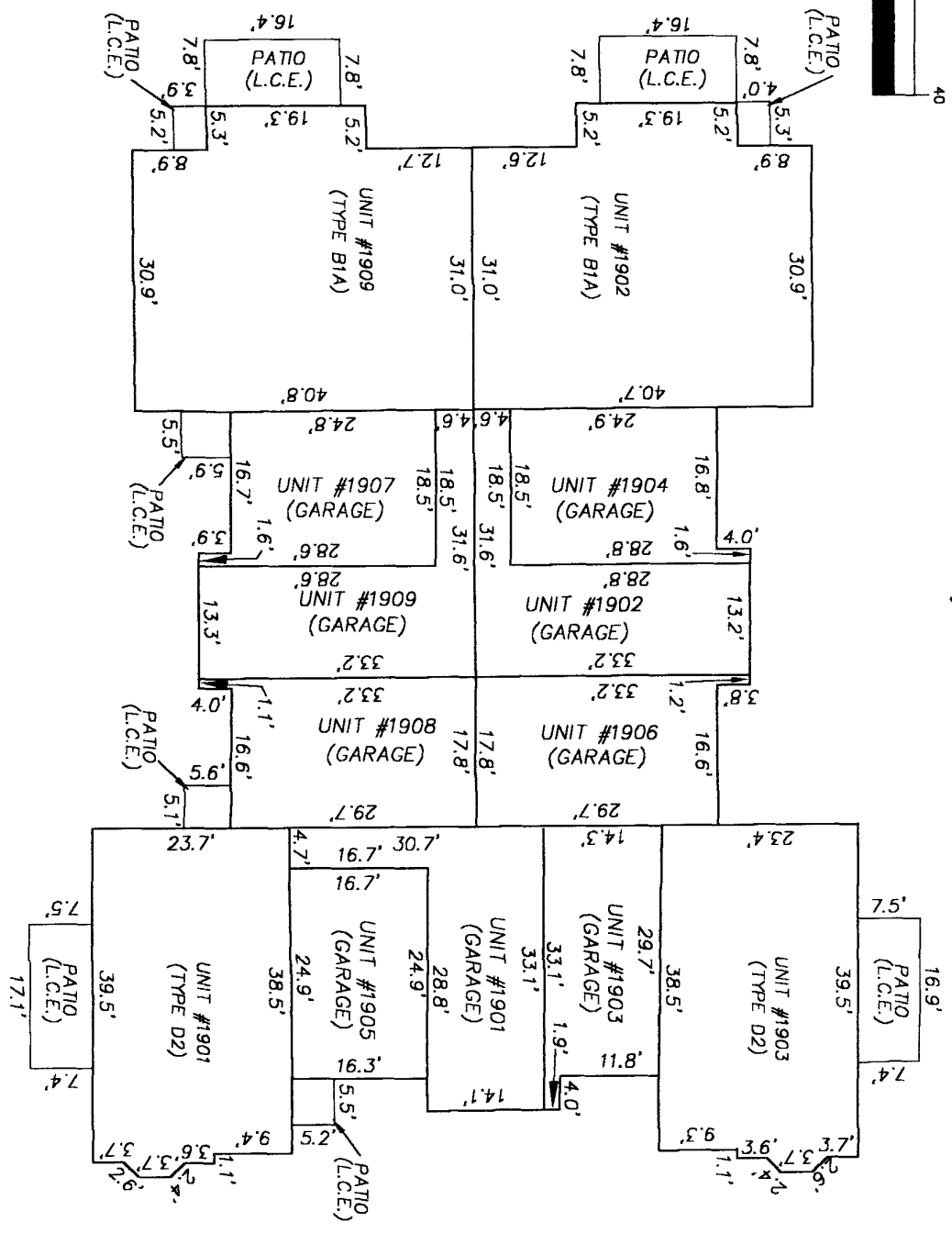

EXHIBIT "B"
HERITAGE DERWOOD, A CONDOMINIUM



L.C.E.=LIMITED COMMON ELEMENT

BUILDING 1900 PLOT PLAN
FIRST FLOOR

RICHARD A. MILLER & ASSOCIATES
 PROFESSIONAL LAND SURVEYORS
 6701 BEACH BLVD, SUITE 100
 JACKSONVILLE, FLORIDA 32225
 (904) 721-5758 (FAX)
 (904) 721-1226 (TEL)

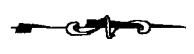
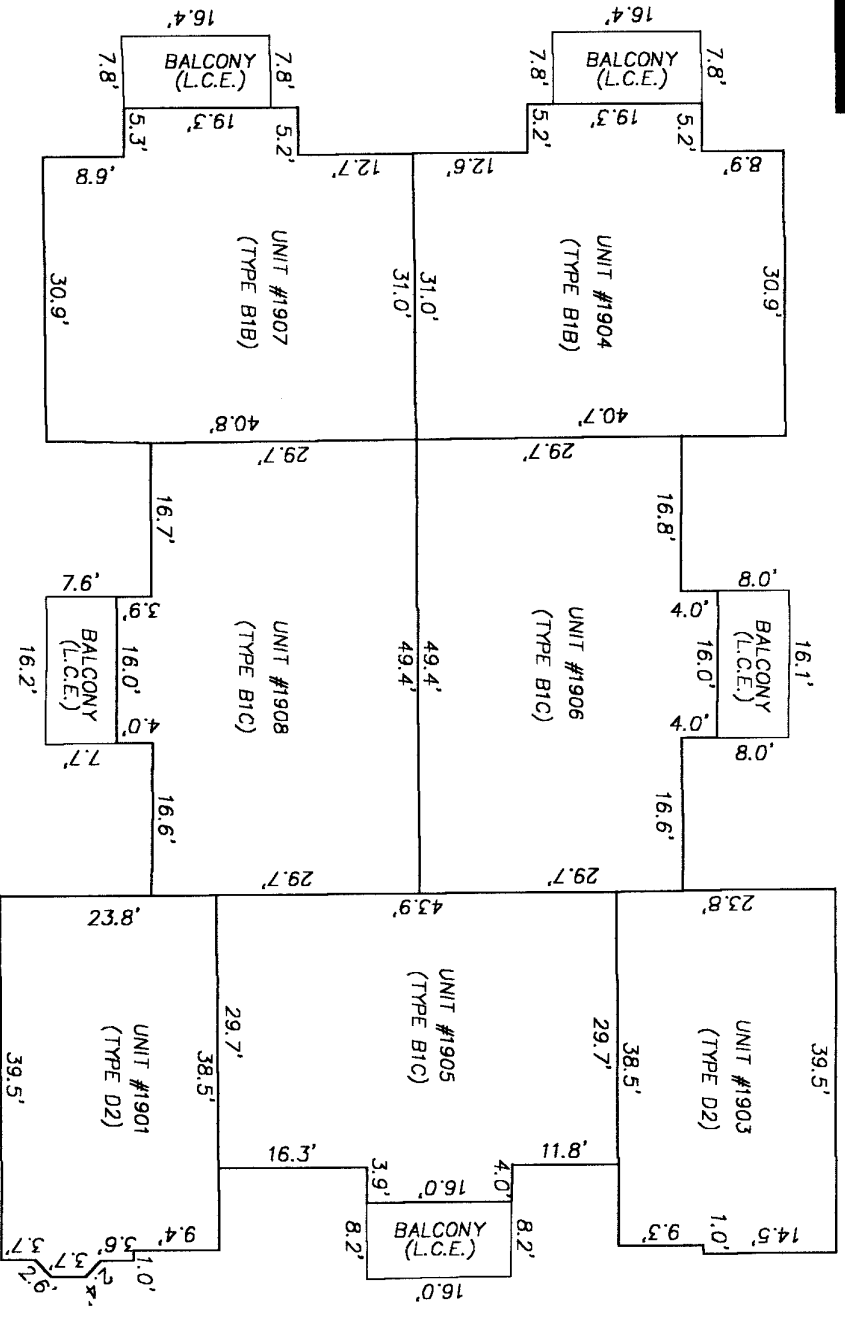
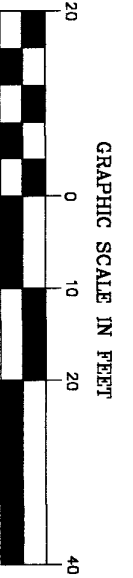

EXHIBIT "B" HERITAGE DEERWOOD, A CONDOMINIUM



L.C.E.=LIMITED COMMON ELEMENT

BUILDING 1900 PLOT PLAN SECOND FLOOR

RICHARD A. MILLER & ASSOCIATES
PROFESSIONAL LAND SURVEYORS
6701 BEACH BLVD., SUITE 100
JACKSONVILLE, FLORIDA 32225
(904) 721-5758 (FAX)
(904) 721-1226 (TEL)



EXHIBIT "B" HERITAGE DEERWOOD, A CONDOMINIUM

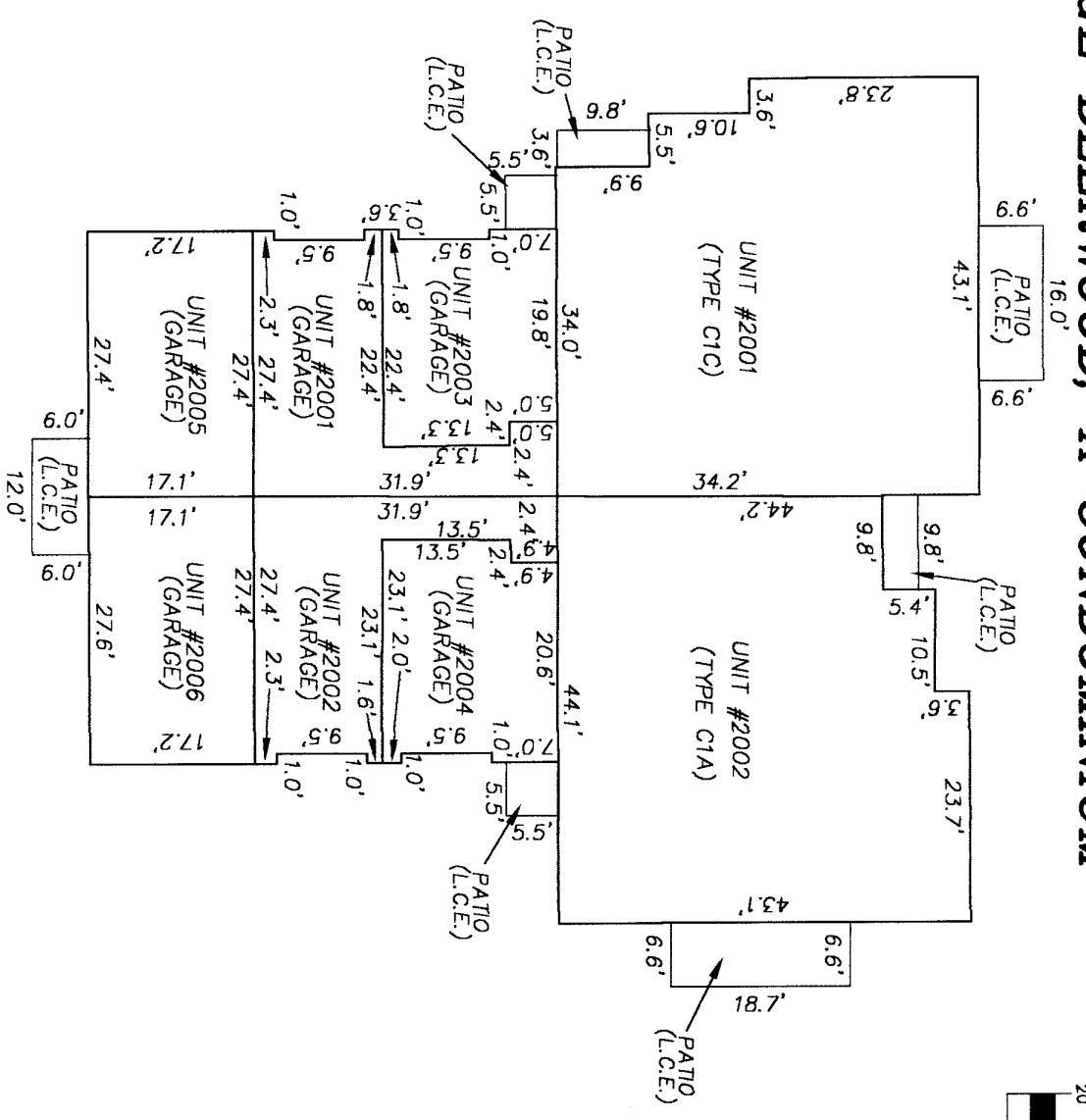

L.C.E.=LIMITED COMMON ELEMENT

RICHARD A. MILLER & ASSOCIATES
 PROFESSIONAL LAND SURVEYORS
 6701 BEACH BLVD. SUITE 100
 JACKSONVILLE, FLORIDA 32225
 (904) 721-5758 (FAX)
 (904) 721-1226 (TEL)

BUILDING 2000 PLOT PLAN FIRST FLOOR

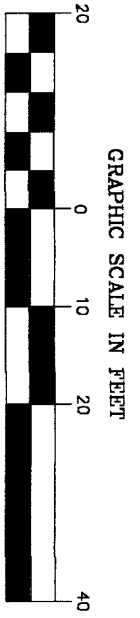
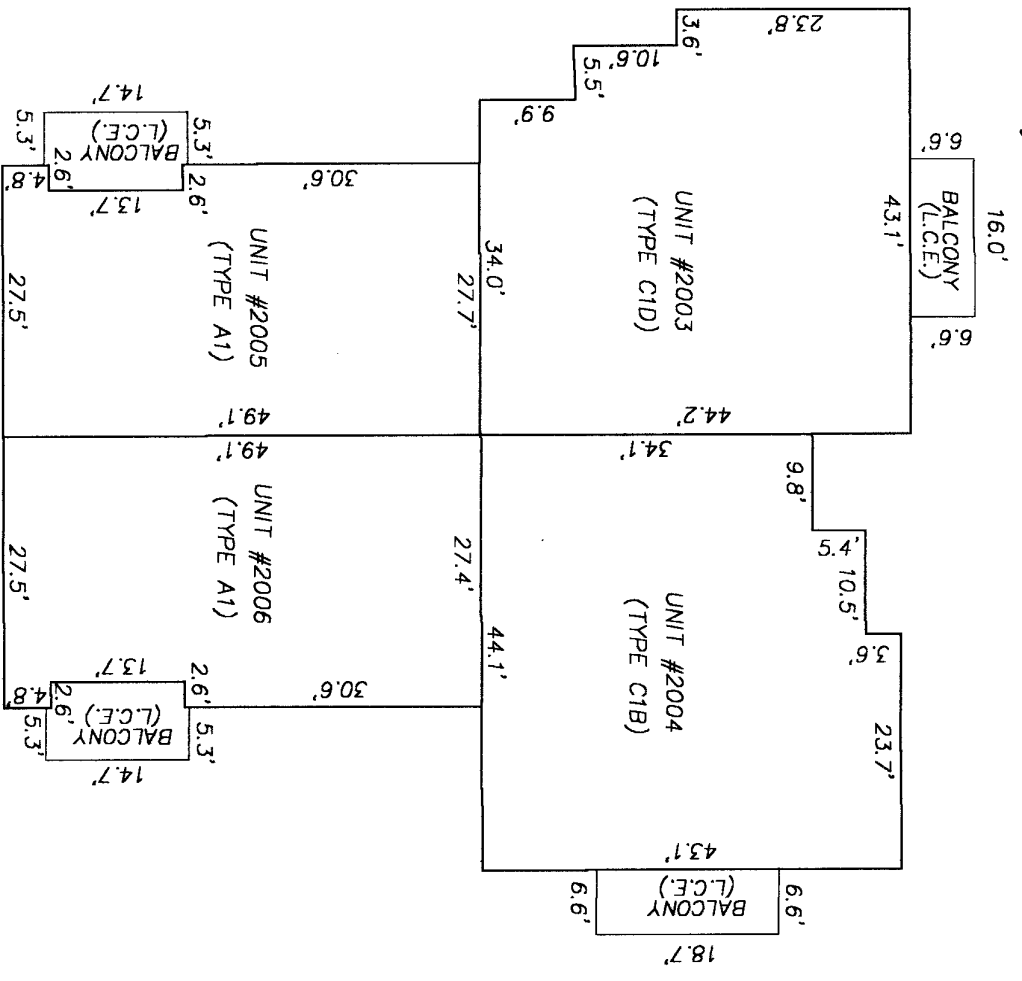
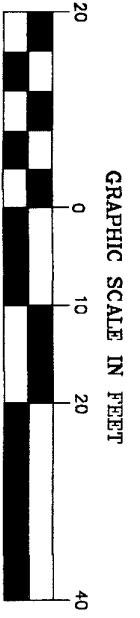

EXHIBIT "B" HERITAGE DEERWOOD, A CONDOMINIUM



L.C.E.=LIMITED COMMON ELEMENT



RICHARD A. MILLER & ASSOCIATES
 PROFESSIONAL LAND SURVEYORS
 6701 BEACH BLVD. SUITE 100
 JACKSONVILLE, FLORIDA 32225
 (904) 721-5758 (FAX)
 (904) 721-1226 (TEL)

BUILDING 2000 PLOT PLAN SECOND FLOOR

AUGUST 25, 2005

SHEET: 71 OF 86

EXHIBIT "B" HERITAGE DEERWOOD, A CONDOMINIUM

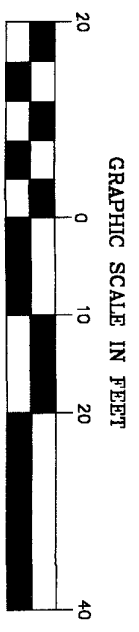
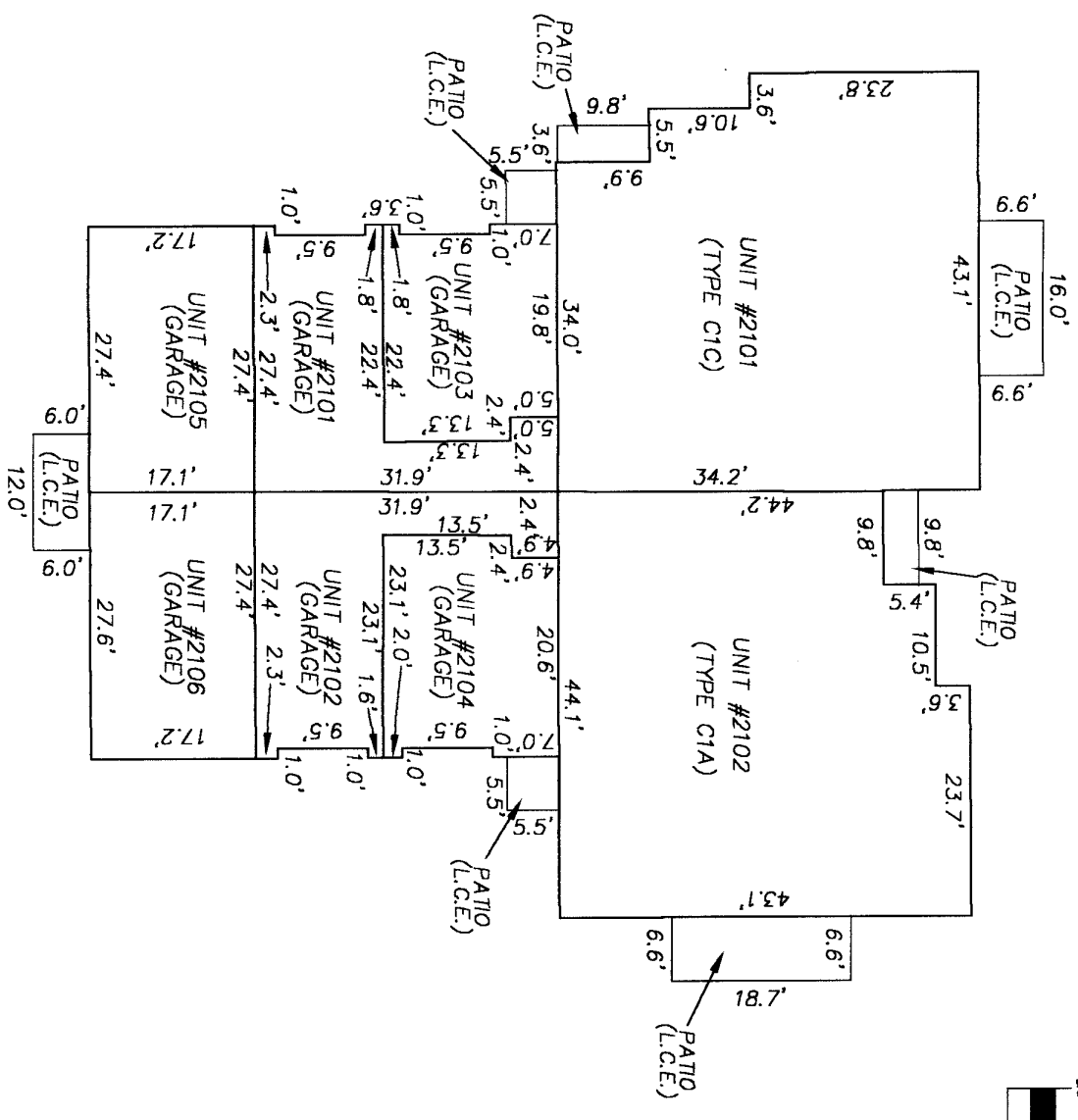

L.C.E.=LIMITED COMMON ELEMENT

RICHARD A. MILLER & ASSOCIATES
 PROFESSIONAL LAND SURVEYORS
 6701 BEACH BLVD, SUITE 100
 JACKSONVILLE, FLORIDA 32225
 (904) 721-5758 (FAX)
 (904) 721-1226 (TEL)

BUILDING 2100 PLOT PLAN FIRST FLOOR

AUGUST 25, 2005

SHEET: 72 of 86

EXHIBIT "B" HERITAGE DEERWOOD, A CONDOMINIUM

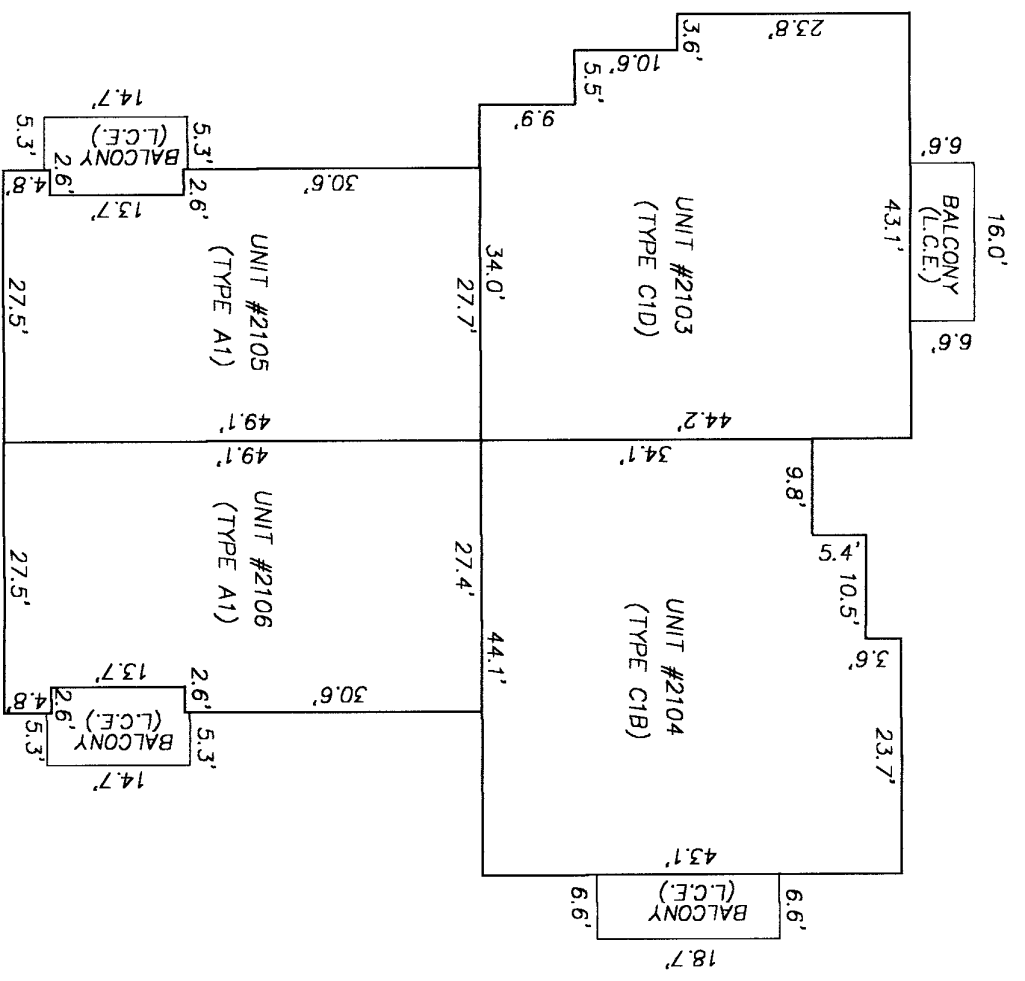

L.C.E.=LIMITED COMMON ELEMENT

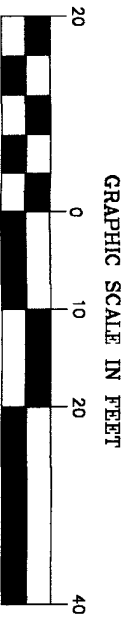

RICHARD A. MILLER & ASSOCIATES
 PROFESSIONAL LAND SURVEYORS
 6701 BEACH BLVD, SUITE 100
 JACKSONVILLE, FLORIDA 32225
 (904) 721-5758 (FAX)
 (904) 721-1226 (TEL)

BUILDING 2100 PLOT PLAN SECOND FLOOR

AUGUST 25, 2005

SHEET: 73 OF 86

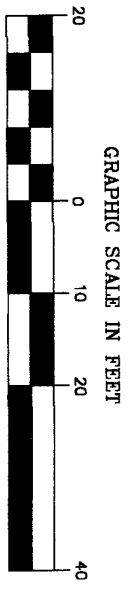
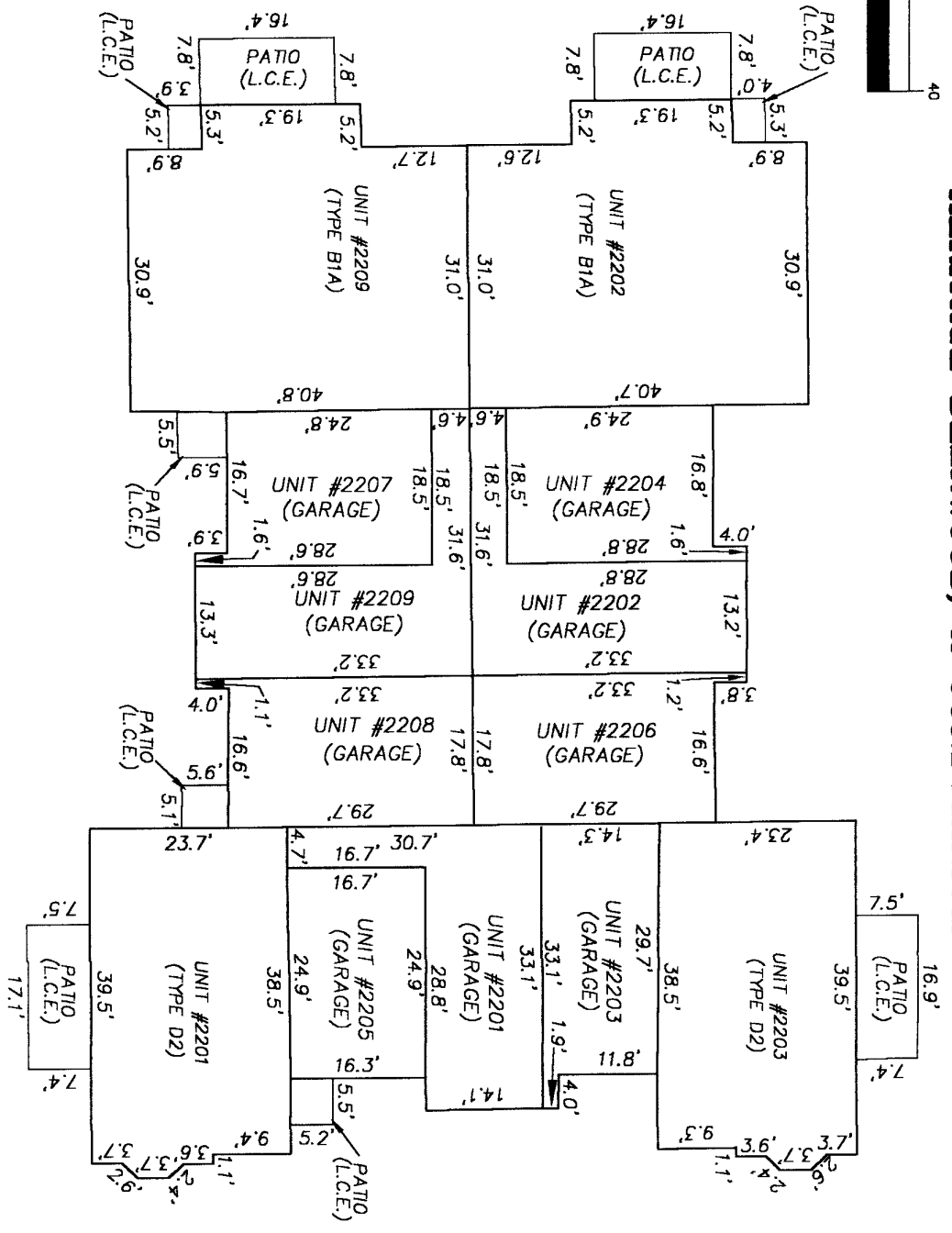

EXHIBIT "B"
HERITAGE DEERWOOD, A CONDOMINIUM



L.C.E.=LIMITED COMMON ELEMENT

BUILDING 2200 PLOT PLAN
FIRST FLOOR

RICHARD A. MILLER & ASSOCIATES
 PROFESSIONAL LAND SURVEYORS
 6701 BEACH BLVD. SUITE 100
 JACKSONVILLE, FLORIDA 32225
 (904) 721-5758 (FAX)
 (904) 721-1226 (TEL)

EXHIBIT "B"
HERITAGE DEERWOOD, A CONDOMINIUM

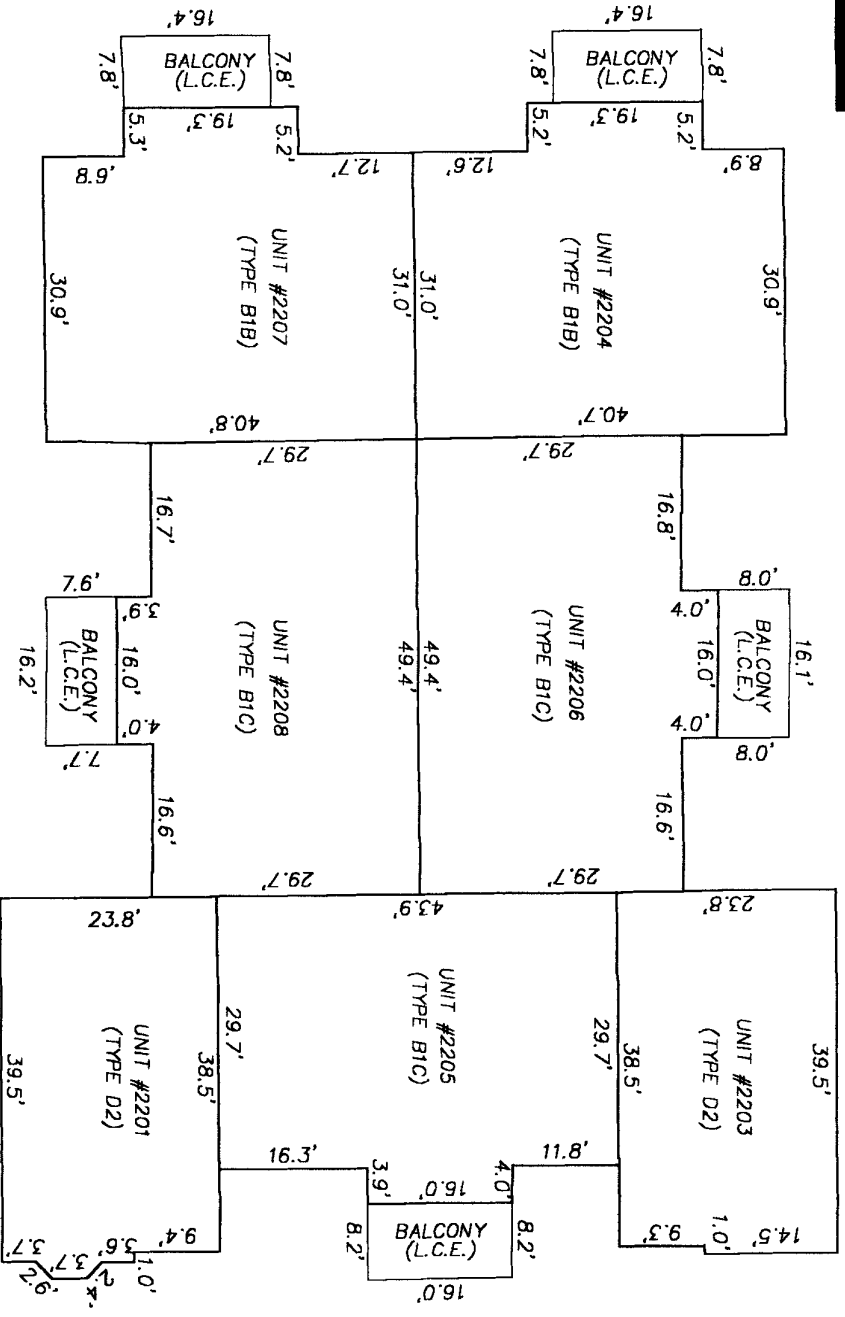
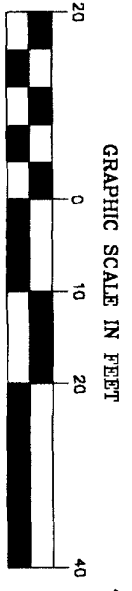

L.C.E.=LIMITED COMMON ELEMENT

BUILDING 2200 PLOT PLAN
SECOND FLOOR

RICHARD A. MILLER & ASSOCIATES
 PROFESSIONAL LAND SURVEYORS
 6701 BEACH BLVD., SUITE 100
 JACKSONVILLE, FLORIDA 32225
 (904) 721-5758 (FAX)
 (904) 721-1226 (TEL)

EXHIBIT "B" HERITAGE DEERWOOD, A CONDOMINIUM

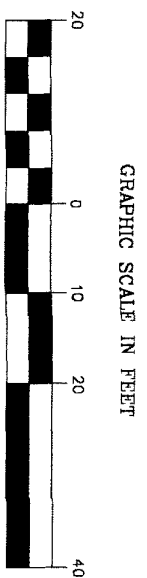
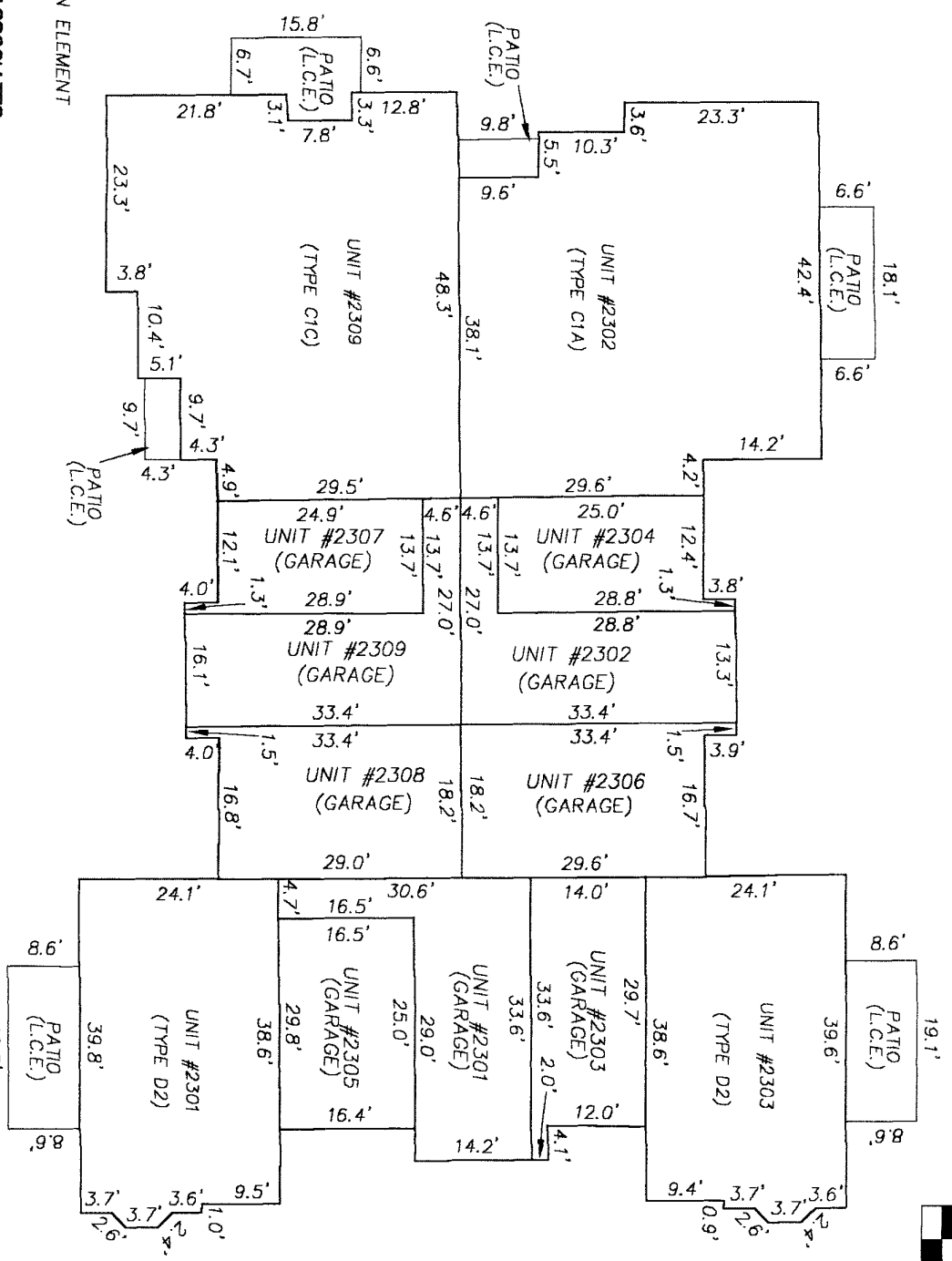

L.C.E.=LIMITED COMMON ELEMENT

BUILDING 2300 PLOT PLAN FIRST FLOOR

RICHARD A. MILLER & ASSOCIATES
 PROFESSIONAL LAND SURVEYORS
 6701 BEACH BLVD., SUITE 100
 JACKSONVILLE, FLORIDA 32225
 (904) 721-5758 (FAX)
 (904) 721-1226 (TEL)

EXHIBIT "B"

HERITAGE DEERWOOD, A CONDOMINIUM

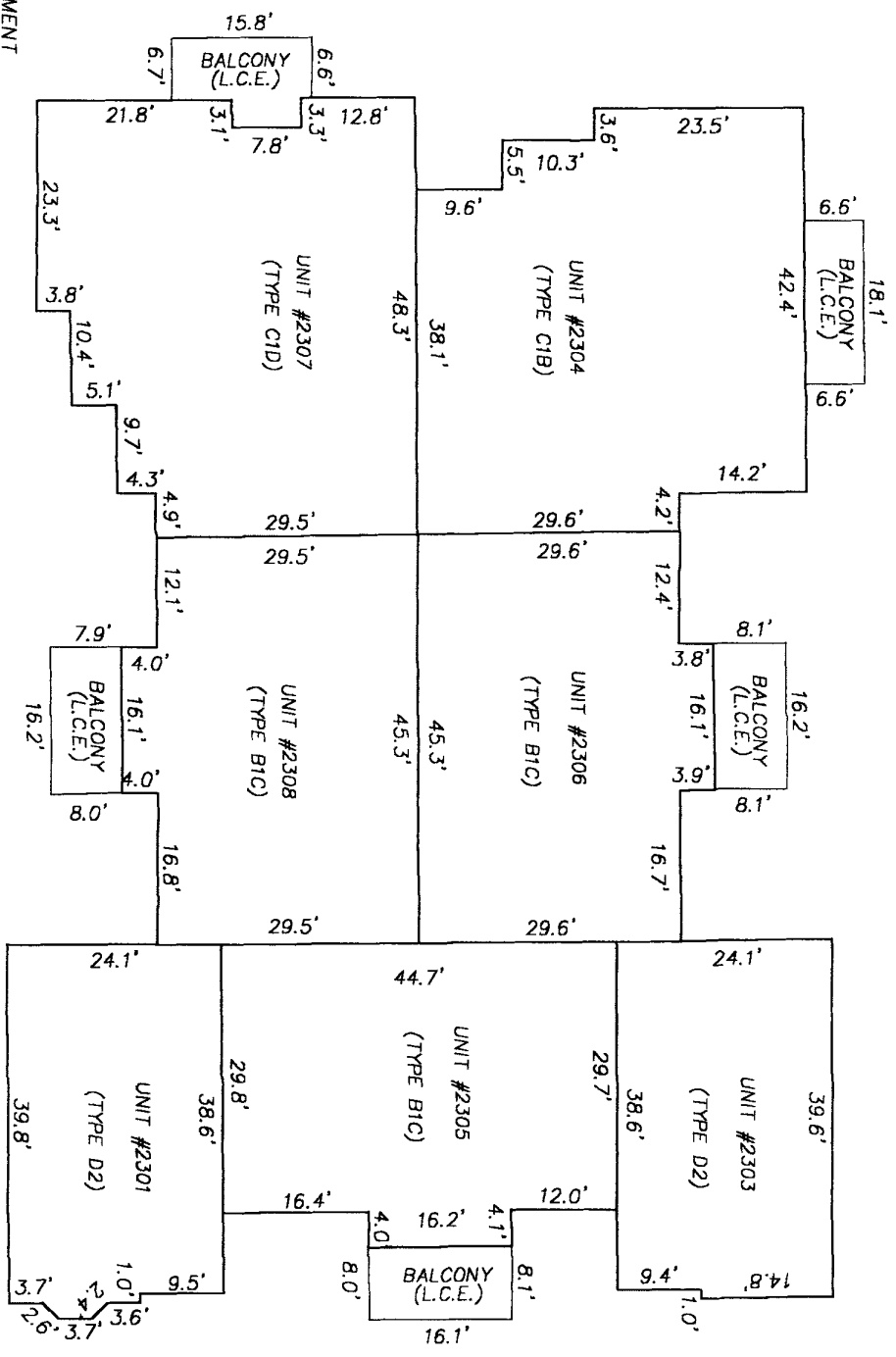
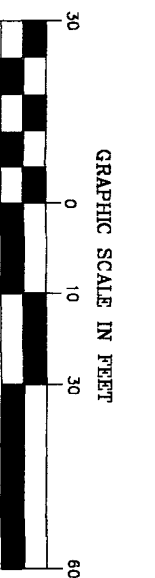

L.C.E.=LIMITED COMMON ELEMENT

RICHARD A. MILLER & ASSOCIATES
 PROFESSIONAL LAND SURVEYORS
 6701 BEACH BLVD. SUITE 100
 JACKSONVILLE, FLORIDA 32225
 (904) 721-5758 (FAX)
 (904) 721-1226 (TEL)

BUILDING 2300 PLOT PLAN SECOND FLOOR

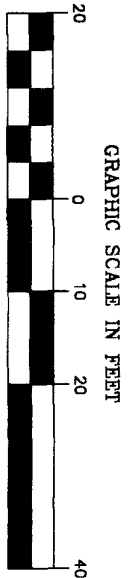
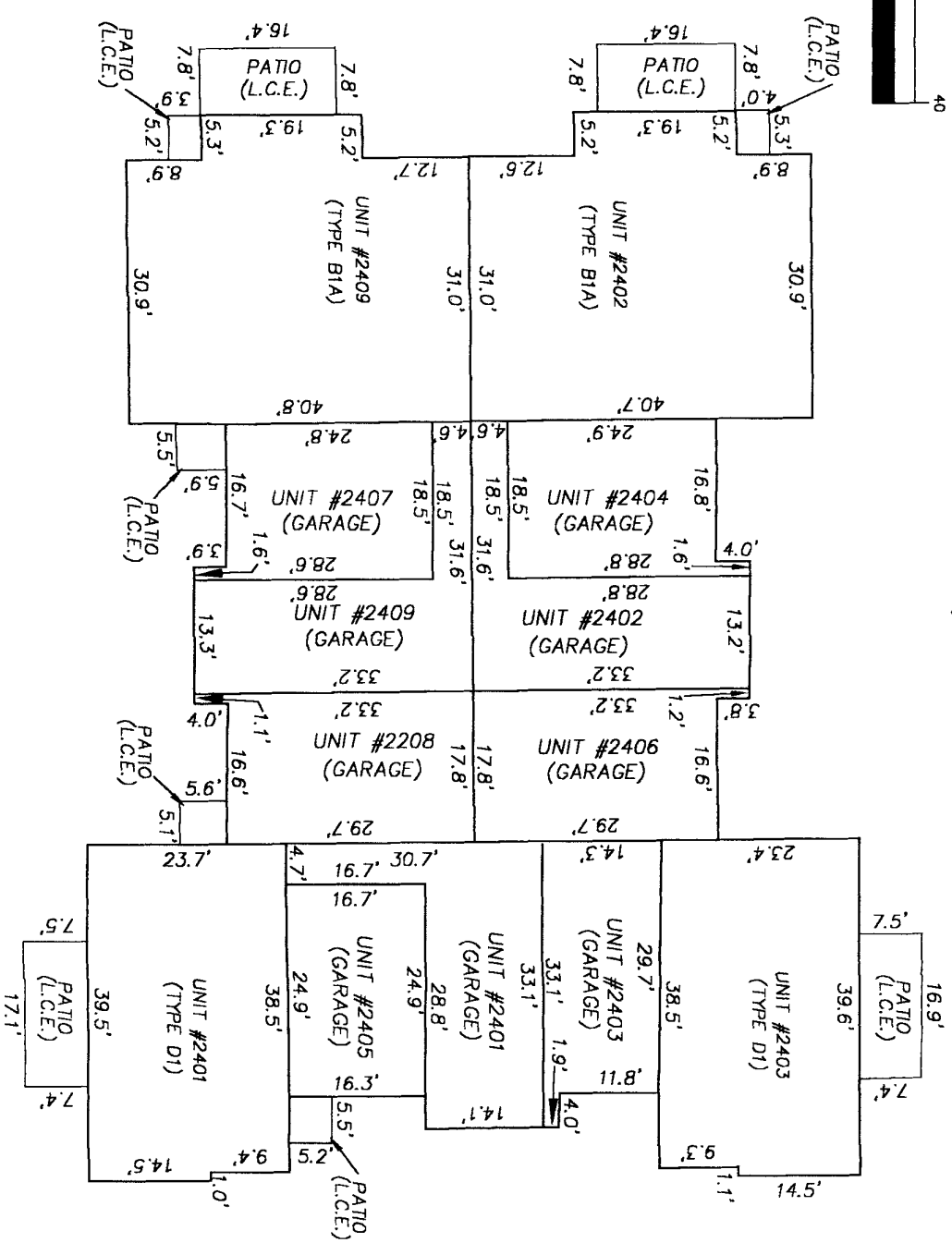

EXHIBIT "B"
HERITAGE DEERWOOD, A CONDOMINIUM



L.C.E.=LIMITED COMMON ELEMENT

RICHARD A. MILLER & ASSOCIATES
 PROFESSIONAL LAND SURVEYORS
 6701 BEACH BLVD., SUITE 100
 JACKSONVILLE, FLORIDA 32225
 (904) 721-5758 (FAX)
 (904) 721-1226 (TEL)

BUILDING 2400 PLOT PLAN
FIRST FLOOR

GRAPHIC SCALE IN FEET



EXHIBIT "B"
HERITAGE DEERWOOD, A CONDOMINIUM

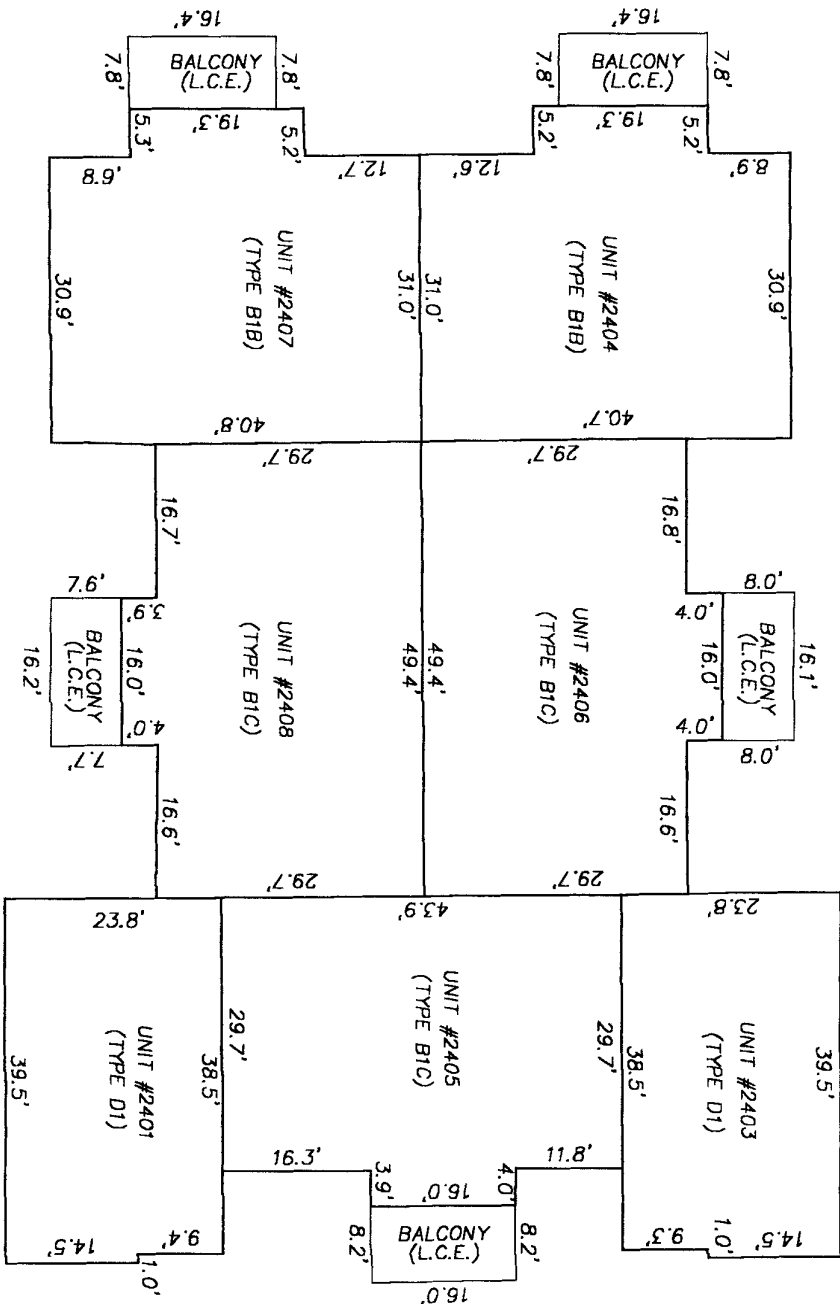

L.C.E.=LIMITED COMMON ELEMENT

BUILDING 2400 PLOT PLAN
SECOND FLOOR

RICHARD A. MILLER & ASSOCIATES
PROFESSIONAL LAND SURVEYORS
6701 BEACH BLVD., SUITE 100
JACKSONVILLE, FLORIDA 32225
(904) 721-5758 (FAX)
(904) 721-1226 (TEL)

EXHIBIT "B" HERITAGE DEERWOOD, A CONDOMINIUM

GRAPHIC SCALE IN FEET

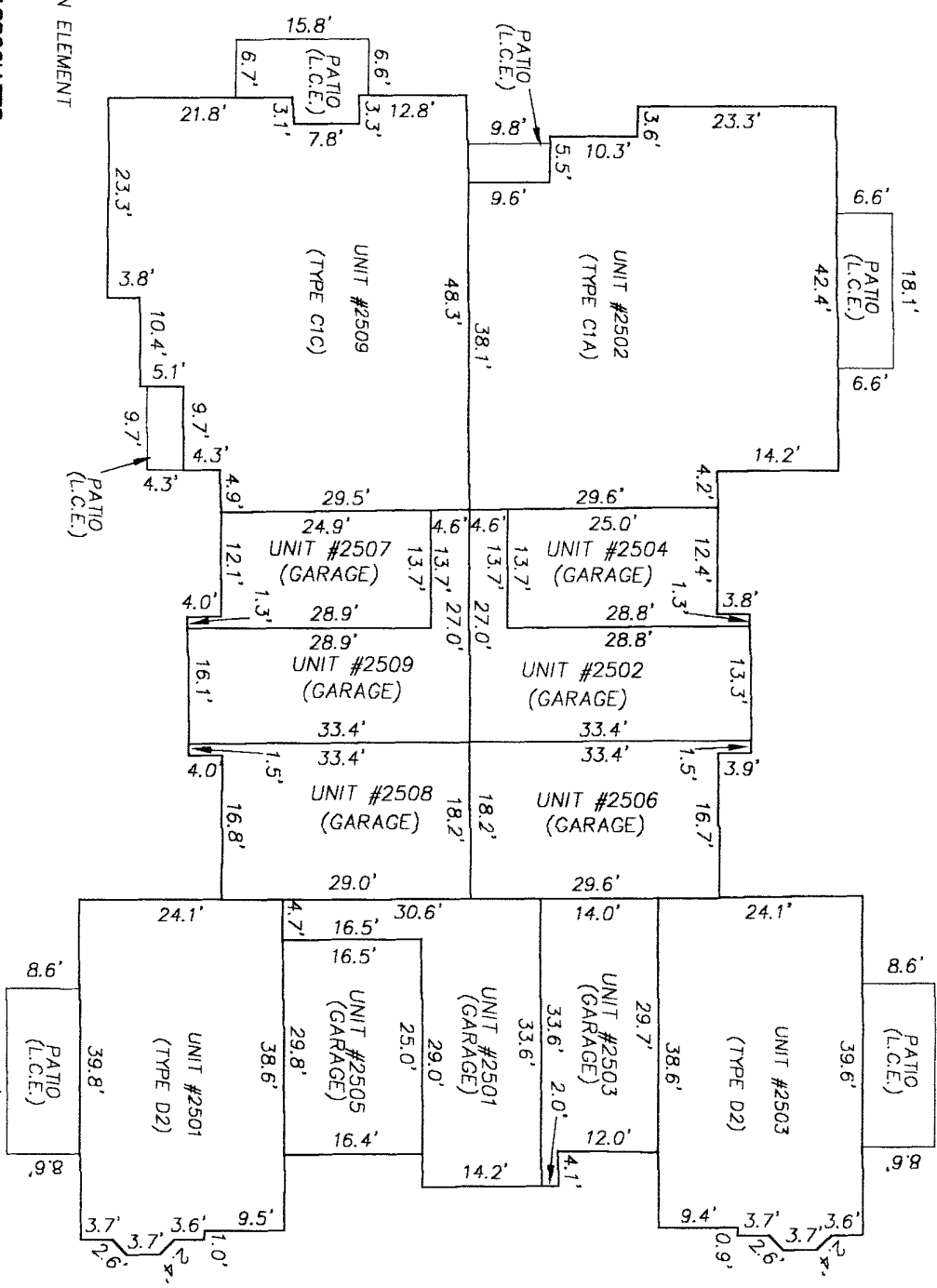

L.C.E.=LIMITED COMMON ELEMENT

RICHARD A. MILLER & ASSOCIATES
 PROFESSIONAL LAND SURVEYORS
 6701 BEACH BLVD, SUITE 100
 JACKSONVILLE, FLORIDA 32225
 (904) 721-5758 (FAX)
 (904) 721-1226 (TEL)

BUILDING 2500 PLOT PLAN FIRST FLOOR

EXHIBIT "B" HERITAGE DEERWOOD, A CONDOMINIUM

GRAPHIC SCALE IN FEET

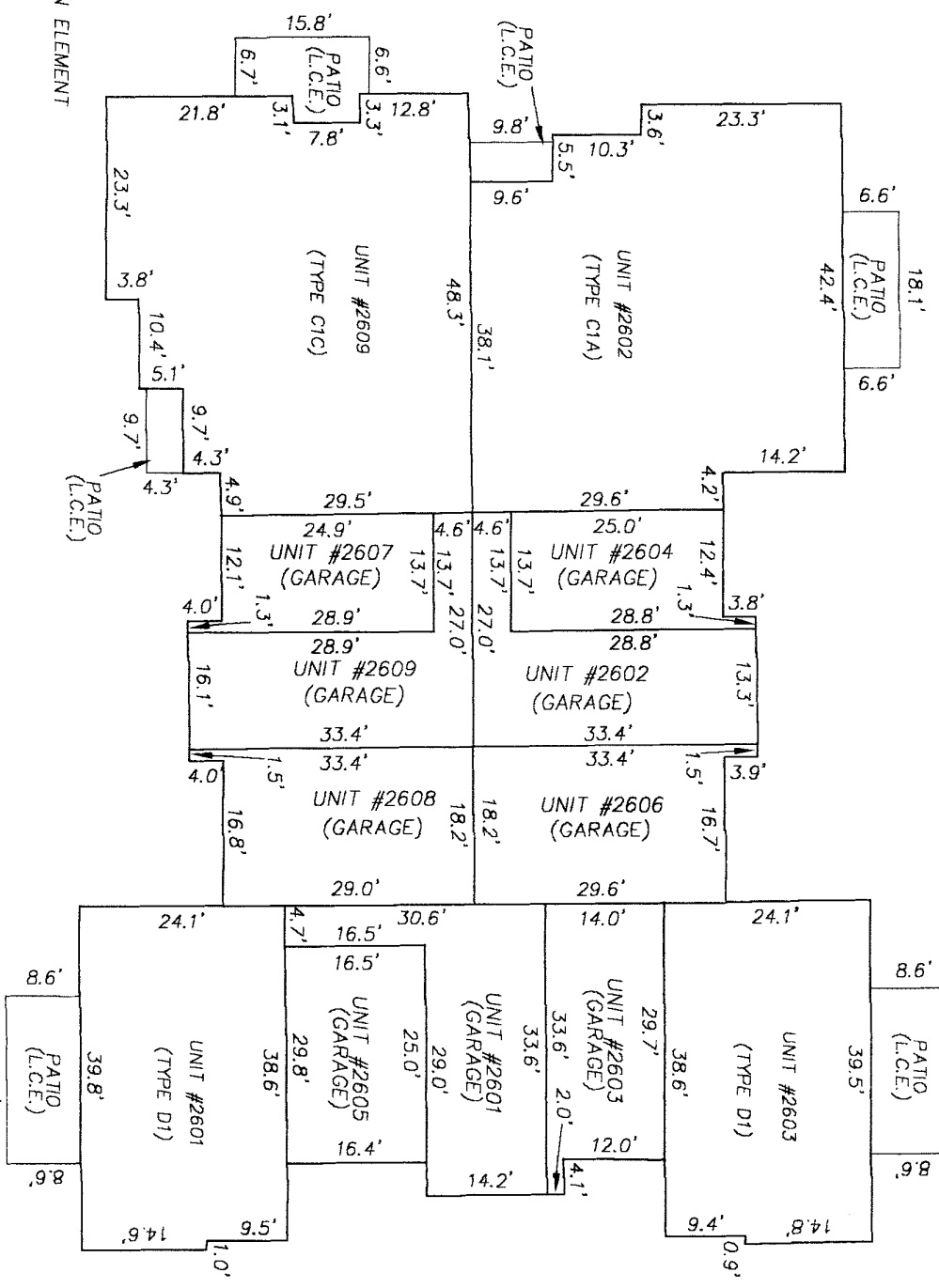

L.C.E.=LIMITED COMMON ELEMENT

BUILDING 2600 PLOT PLAN FIRST FLOOR

RICHARD A. MILLER & ASSOCIATES
 PROFESSIONAL LAND SURVEYORS
 6701 BEACH BLVD, SUITE 100
 JACKSONVILLE, FLORIDA 32225
 (904) 721-5758 (FAX)
 (904) 721-1226 (TEL)

EXHIBIT "B" HERITAGE DEERWOOD, A CONDOMINIUM

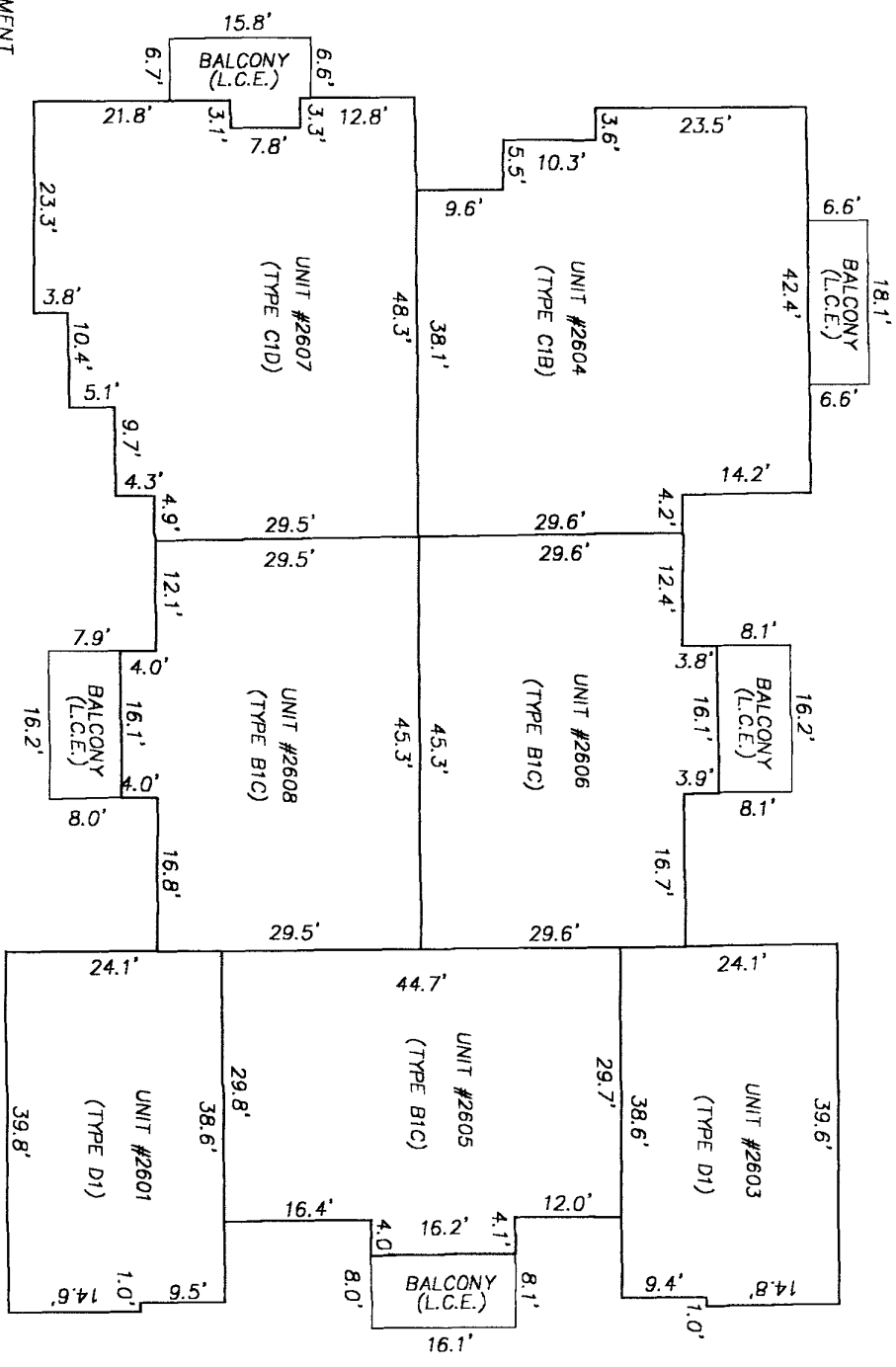
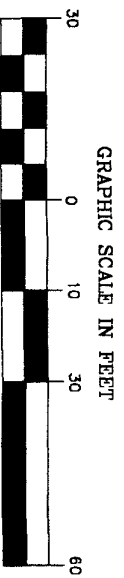

L.C.E. = LIMITED COMMON ELEMENT

RICHARD A. MILLER & ASSOCIATES
 PROFESSIONAL LAND SURVEYORS
 6701 BEACH BLVD., SUITE 100
 JACKSONVILLE, FLORIDA 32225
 (904) 721-5758 (FAX)
 (904) 721-1226 (TEL)

BUILDING 2600 PLOT PLAN SECOND FLOOR

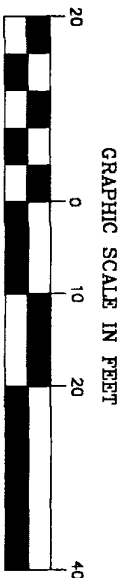
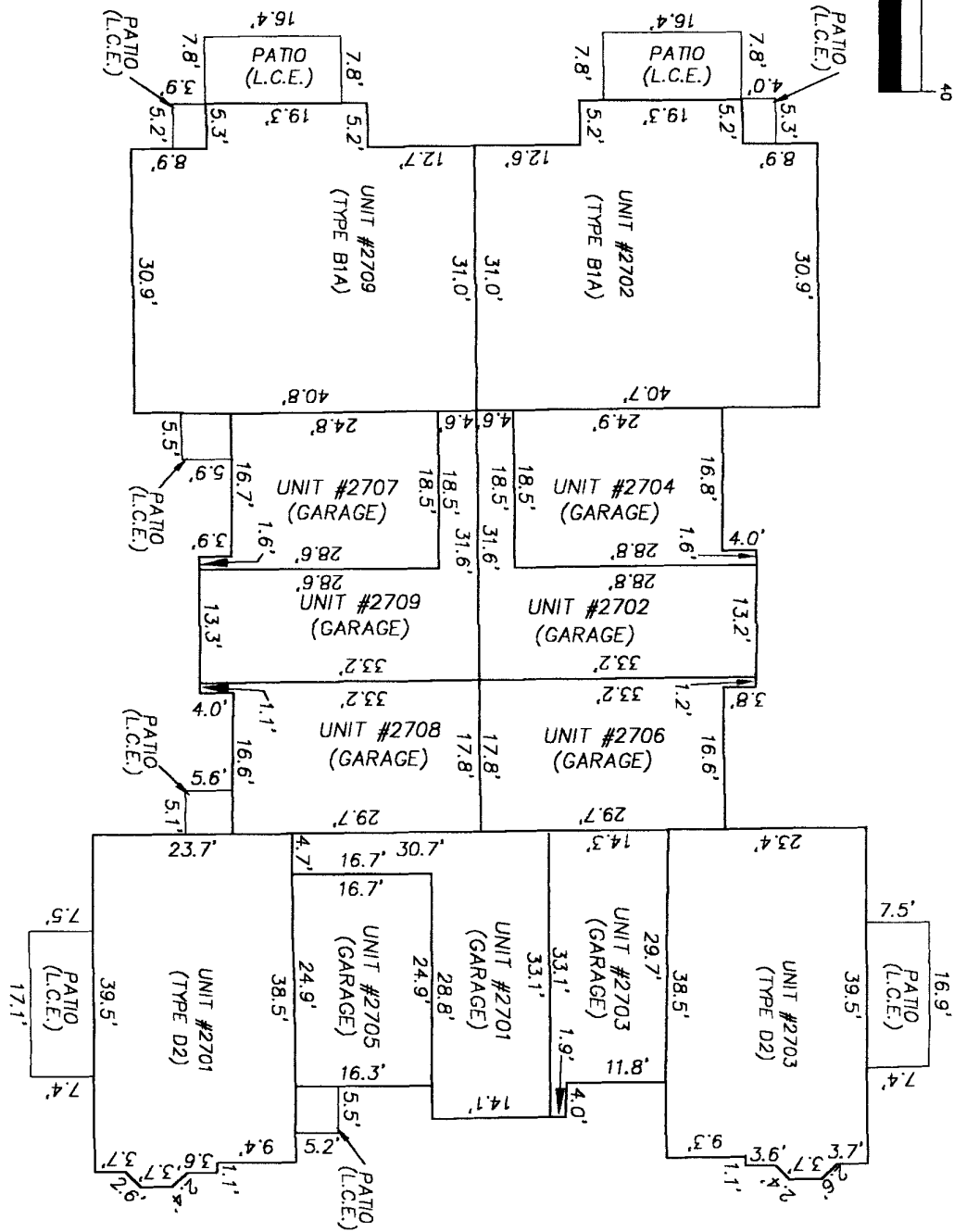

EXHIBIT "B" HERITAGE DEERWOOD, A CONDOMINIUM



BUILDING 2700 PLOT PLAN FIRST FLOOR

RICHARD A. MILLER & ASSOCIATES
 PROFESSIONAL LAND SURVEYORS
 6701 BEACH BLVD, SUITE 100
 JACKSONVILLE, FLORIDA 32225
 (904) 721-5758 (FAX)
 (904) 721-1226 (TEL)

EXHIBIT "B" HERITAGE DEERWOOD, A CONDOMINIUM

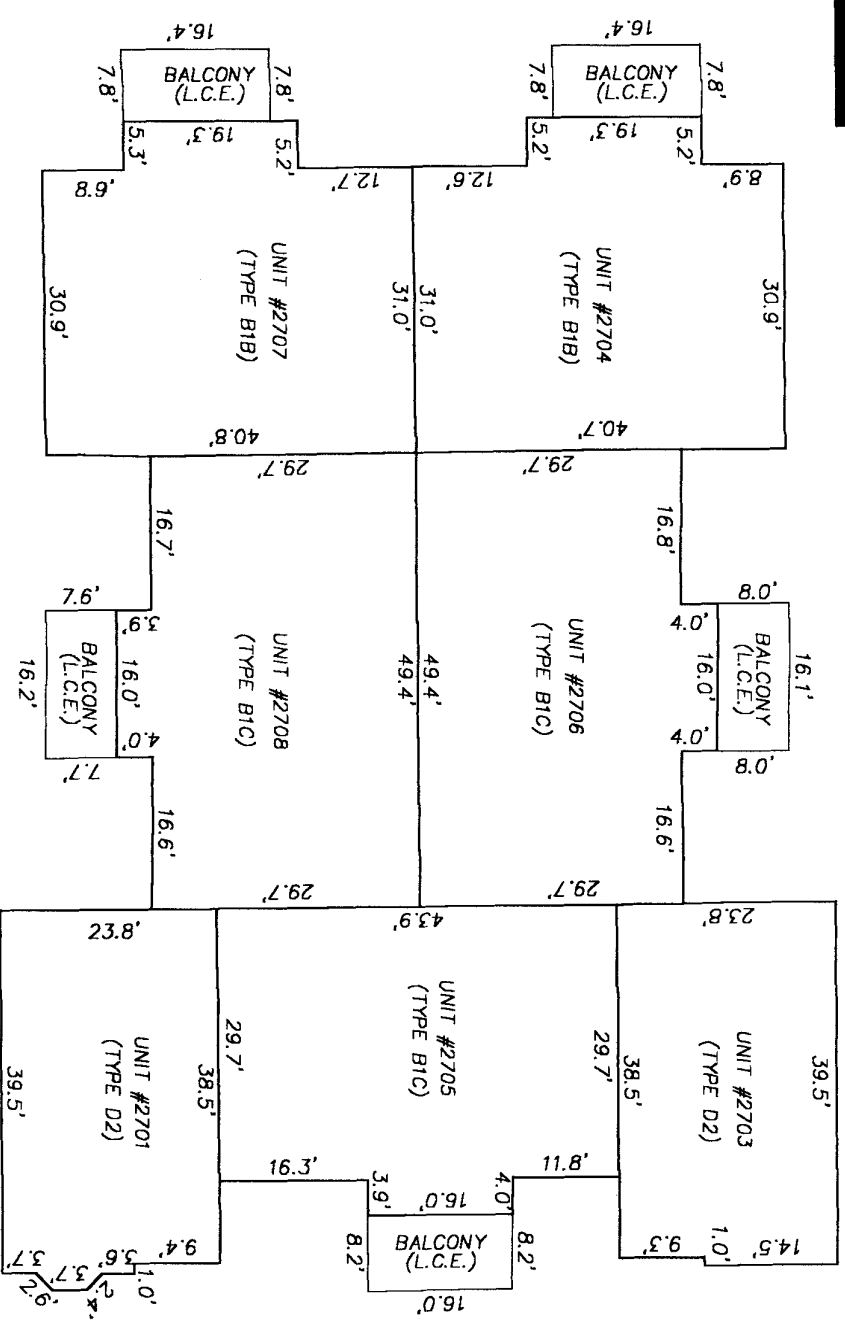
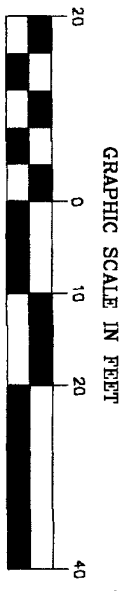

BUILDING 2700 PLOT PLAN SECOND FLOOR

RICHARD A. MILLER & ASSOCIATES
 PROFESSIONAL LAND SURVEYORS
 6701 BEACH BLVD., SUITE 100
 JACKSONVILLE, FLORIDA 32225
 (904) 721-5758 (FAX)
 (904) 721-1226 (TEL)

HERITAGE DEERWOOD, A CONDOMINIUM

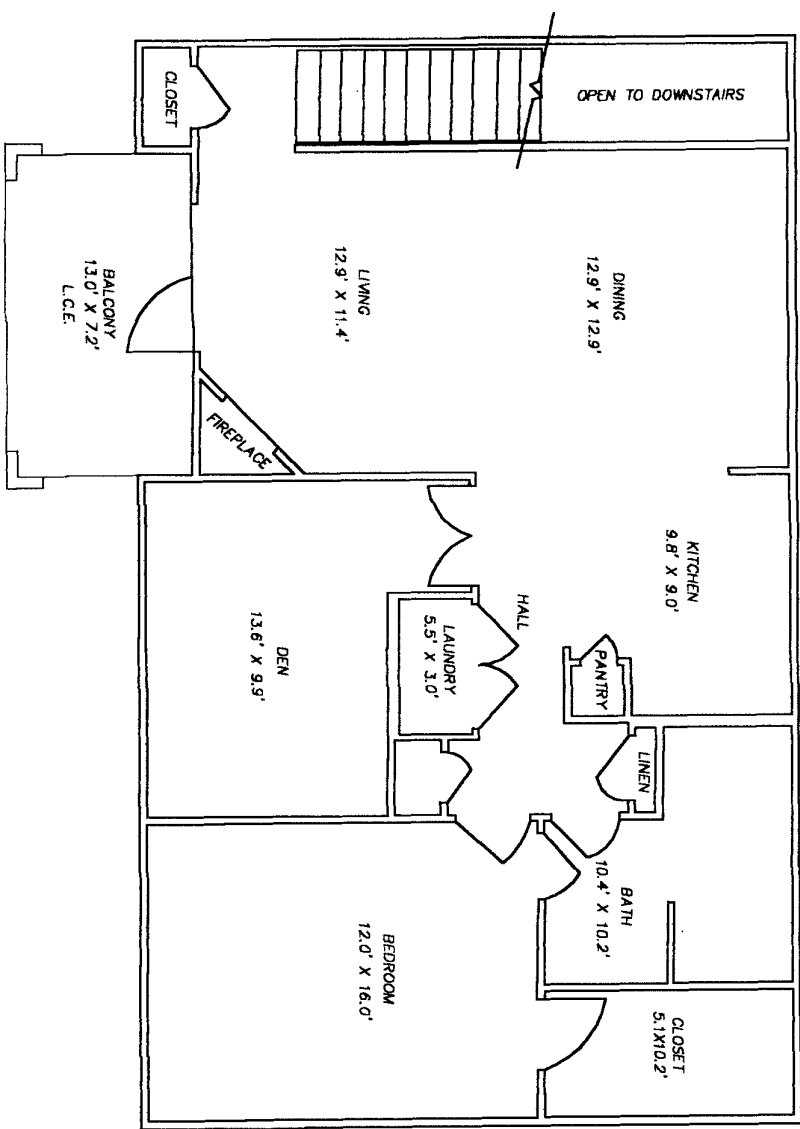

APPLIES TO

UNIT #1206	UNIT #1806
UNIT #206	UNIT #1706
UNIT #1206	UNIT #1806
UNIT #1306	UNIT #2006
UNIT #1406	UNIT #2106
UNIT #1506	

UNIT TYPE A1 FLOOR PLAN

RICHARD A. MILLER & ASSOCIATES
 PROFESSIONAL LAND SURVEYORS
 6701 BEACH BLVD. SUITE 100
 JACKSONVILLE, FLORIDA 32225
 (904) 721-5758 (FAX)
 (904) 721-1226 (TEL)

AUGUST 25, 2005

SHEET: 1 OF 16

HERITAGE DEERWOOD, A CONDOMINIUM

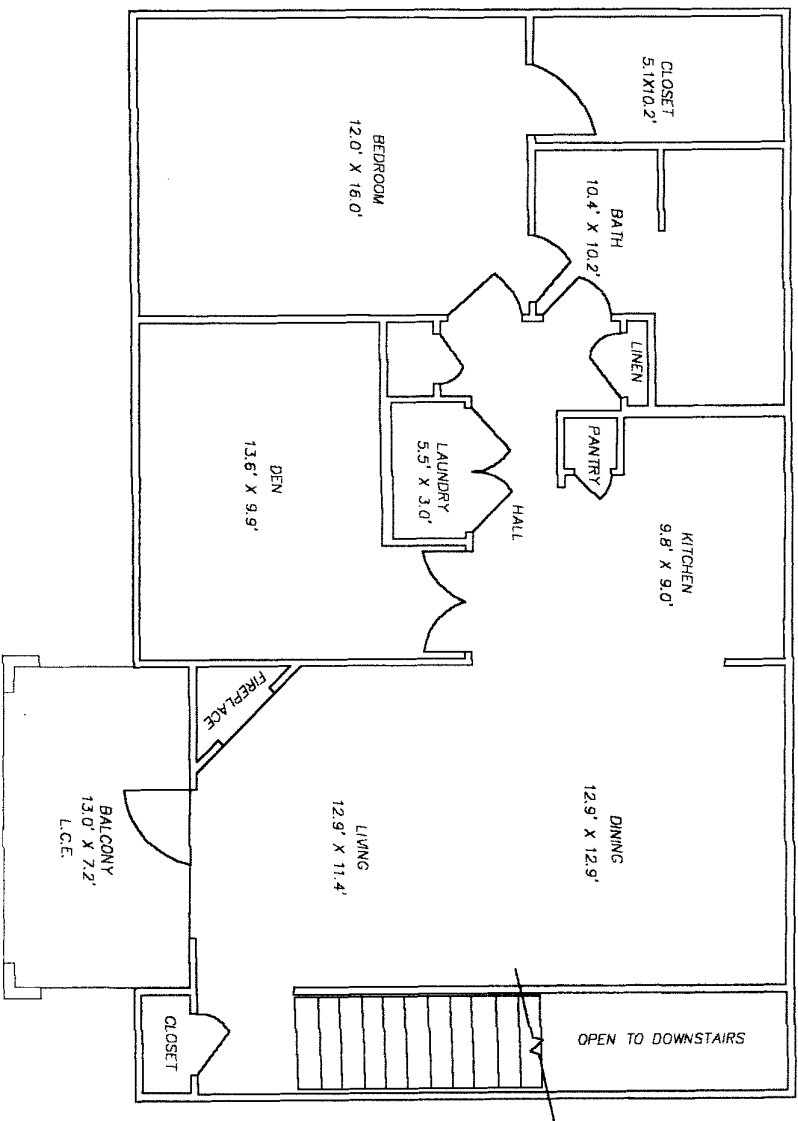
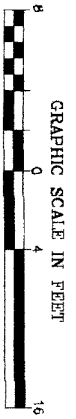

L.C.E.=LIMITED COMMON ELEMENT

APPLIES TO

UNIT #105	UNIT #1605
UNIT #205	UNIT #1705
UNIT #1205	UNIT #1805
UNIT #1305	UNIT #2005
UNIT #1405	UNIT #2105
UNIT #1505	

UNIT TYPE A1 - REVERSE FLOOR PLAN

RICHARD A. MILLER & ASSOCIATES
 PROFESSIONAL LAND SURVEYORS
 6701 BEACH BLVD. SUITE 100
 JACKSONVILLE, FLORIDA 32225
 (904) 721-5758 (FAX)
 (904) 721-1226 (TEL)

AUGUST 25, 2005

SHEET: 2 OF 16

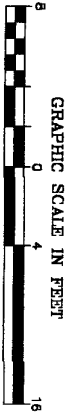

HERITAGE DEERWOOD, A CONDOMINIUM

- UNIT #101 UNIT #1301
 UNIT #201 UNIT #1401
 UNIT #409 UNIT #1909
 UNIT #609 UNIT #2209
 UNIT #809 UNIT #2409
 UNIT #1009 UNIT #2709

APPLIES TO

L.C.E.=LIMITED COMMON ELEMENT

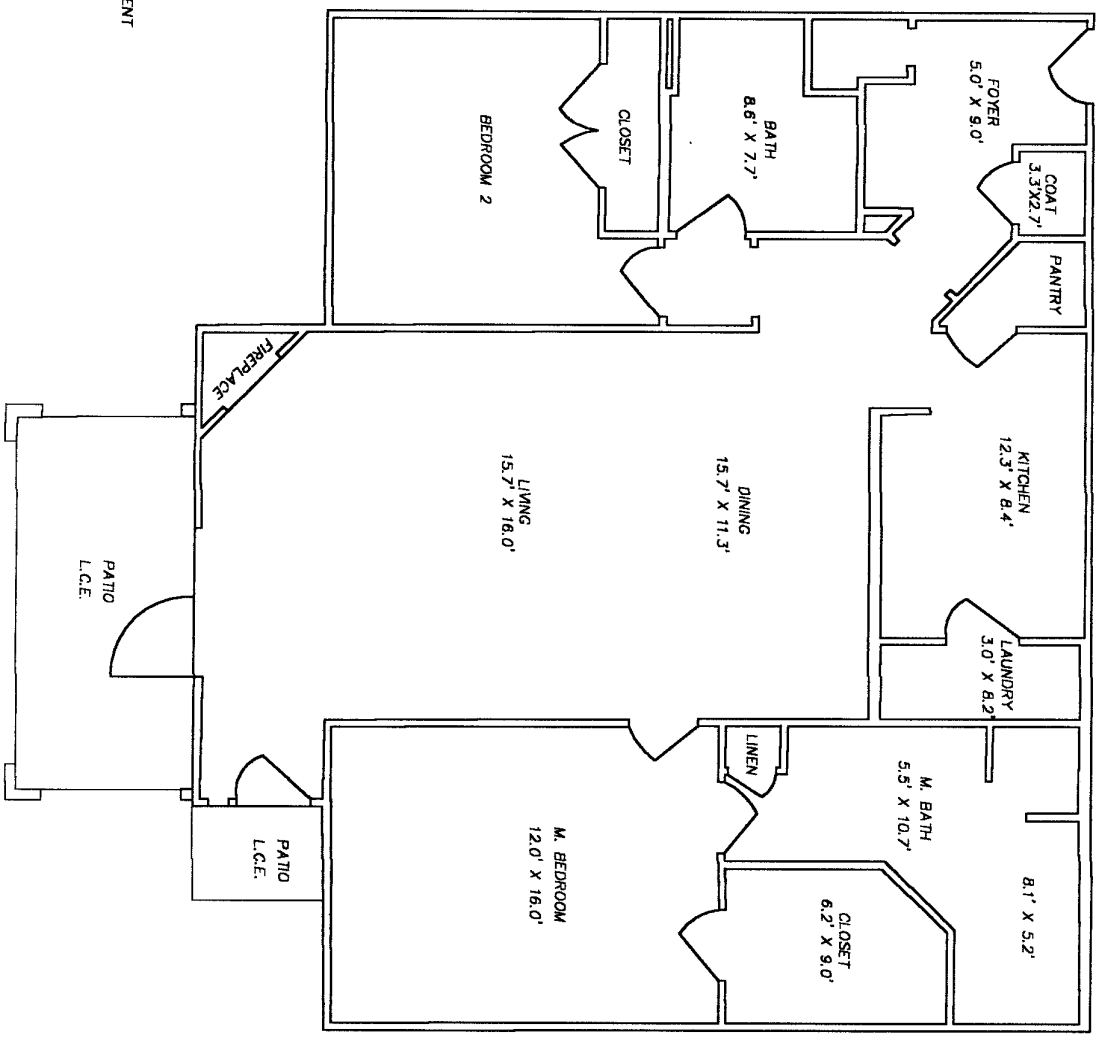

RICHARD A. MILLER & ASSOCIATES
 PROFESSIONAL LAND SURVEYORS
 6701 BEACH BLVD., SUITE 100
 JACKSONVILLE, FLORIDA 32225
 (904) 721-5758 (FAX)
 (904) 721-1226 (TEL)

UNIT TYPE B1A FLOOR PLAN

AUGUST 25, 2005

SHEET: 3 OF 16

HERITAGE DEERWOOD, A CONDOMINIUM

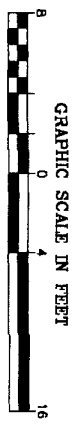

- APPLIES TO
- | | |
|------------|------------|
| UNIT #102 | UNIT #1302 |
| UNIT #202 | UNIT #1402 |
| UNIT #402 | UNIT #1902 |
| UNIT #602 | UNIT #2202 |
| UNIT #802 | UNIT #2402 |
| UNIT #1002 | UNIT #2702 |

L.C.E.=LIMITED COMMON ELEMENT

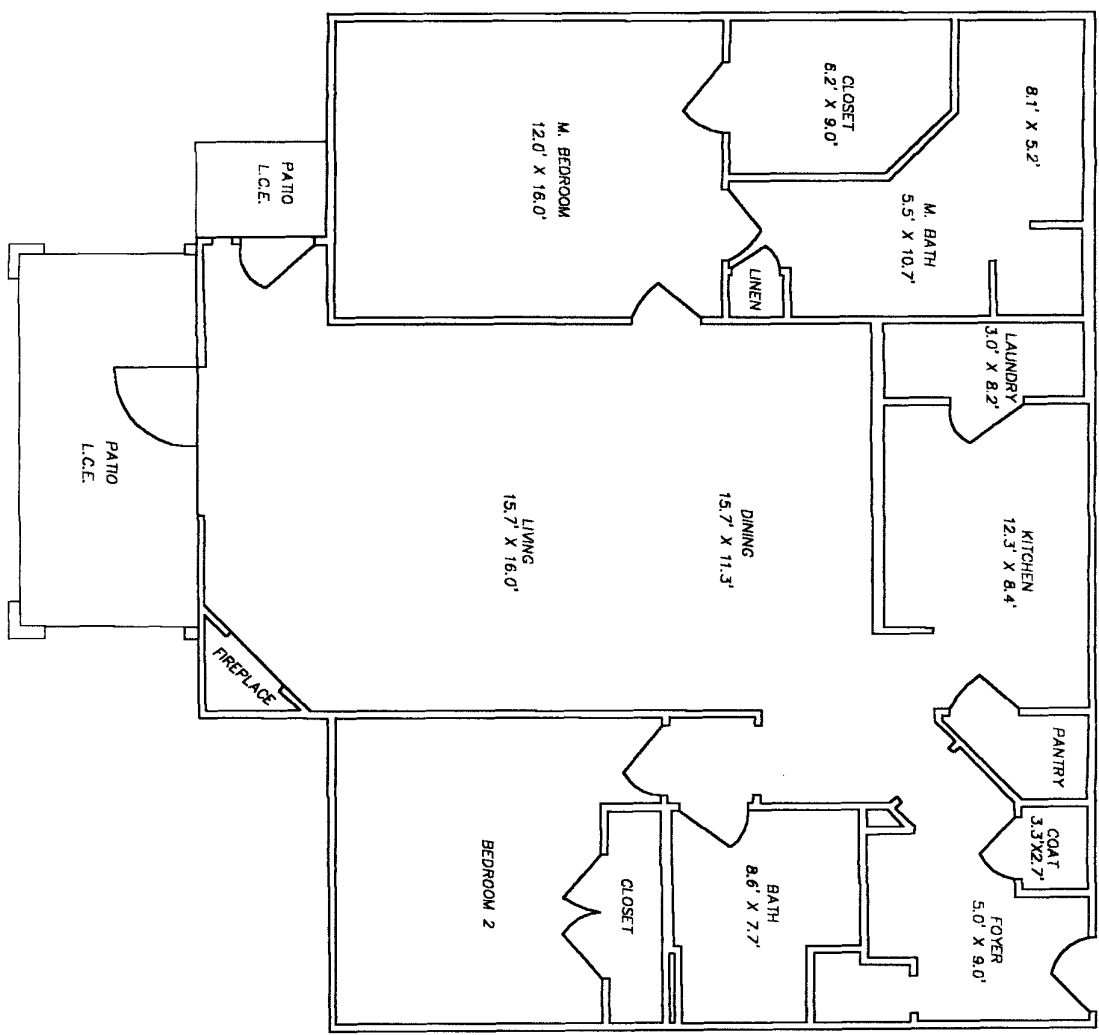

UNIT TYPE B1A REVERSE FLOOR PLAN

RICHARD A. MILLER & ASSOCIATES
 PROFESSIONAL LAND SURVEYORS
 6701 BEACH BLVD. SUITE 100
 JACKSONVILLE, FLORIDA 32225
 (904) 721-5758 (FAX)
 (904) 721-1226 (TEL)

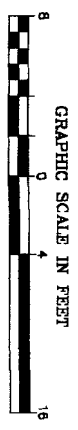

HERITAGE DEERWOOD, A CONDOMINIUM

APPLIES TO

UNIT #103	UNIT #1303
UNIT #203	UNIT #1403
UNIT #407	UNIT #1907
UNIT #607	UNIT #2207
UNIT #807	UNIT #2407
UNIT #1007	UNIT #2707

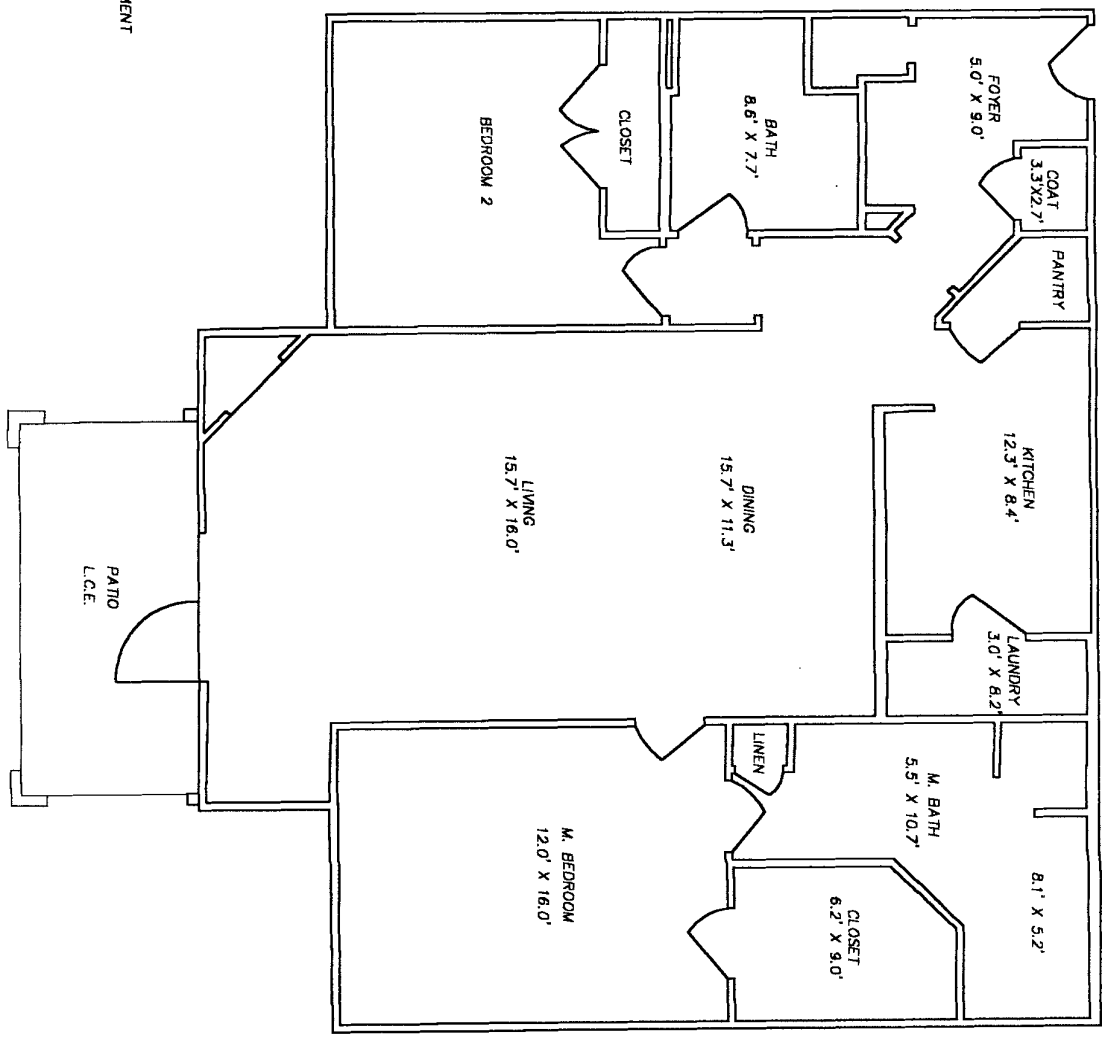

L.C.E.=LIMITED COMMON ELEMENT

RICHARD A. MILLER & ASSOCIATES
 PROFESSIONAL LAND SURVEYORS
 6701 BEACH BLVD. SUITE 100
 JACKSONVILLE, FLORIDA 32225
 (904) 721-5758 (FAX)
 (904) 721-1226 (TEL)

UNIT TYPE B1B FLOOR PLAN

AUGUST 25, 2005

SHEET: 5 OF 16

HERITAGE DEERWOOD, A CONDOMINIUM

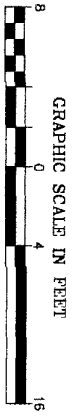

- APPLIES TO
- | | |
|------------|------------|
| UNIT #1304 | UNIT #104 |
| UNIT #1404 | UNIT #204 |
| UNIT #1904 | UNIT #404 |
| UNIT #2204 | UNIT #604 |
| UNIT #2404 | UNIT #804 |
| UNIT #2704 | UNIT #1004 |

L.C.E.=LIMITED COMMON ELEMENT

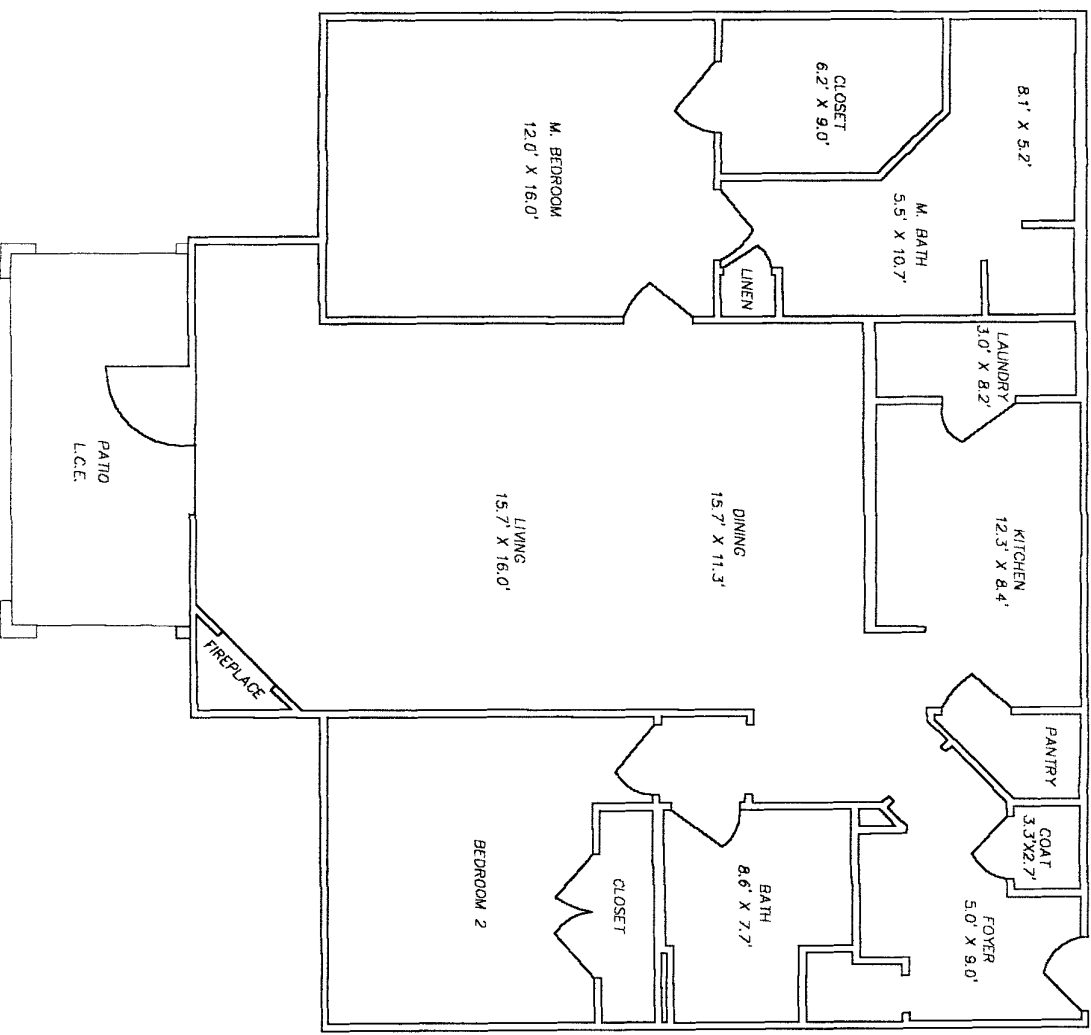

RICHARD A. MILLER & ASSOCIATES
 PROFESSIONAL LAND SURVEYORS
 6701 BEACH BLVD. SUITE 100
 JACKSONVILLE, FLORIDA 32225
 (904) 721-5758 (FAX)
 (904) 721-1226 (TEL)

UNIT TYPE B1B REVERSE FLOOR PLAN

HERITAGE DEERWOOD, A CONDOMINIUM

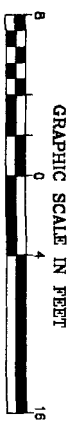

APPLIES TO

UNIT #305	UNIT #705	UNIT #1105	UNIT #2405
UNIT #306	UNIT #706	UNIT #1106	UNIT #2406
UNIT #405	UNIT #805	UNIT #1905	UNIT #2505
UNIT #406	UNIT #806	UNIT #1906	UNIT #2506
UNIT #505	UNIT #905	UNIT #2205	UNIT #2605
UNIT #506	UNIT #906	UNIT #2206	UNIT #2606
UNIT #605	UNIT #1005	UNIT #2305	UNIT #2705
UNIT #606	UNIT #1006	UNIT #2306	UNIT #2706

L.C.E. = LIMITED COMMON ELEMENT

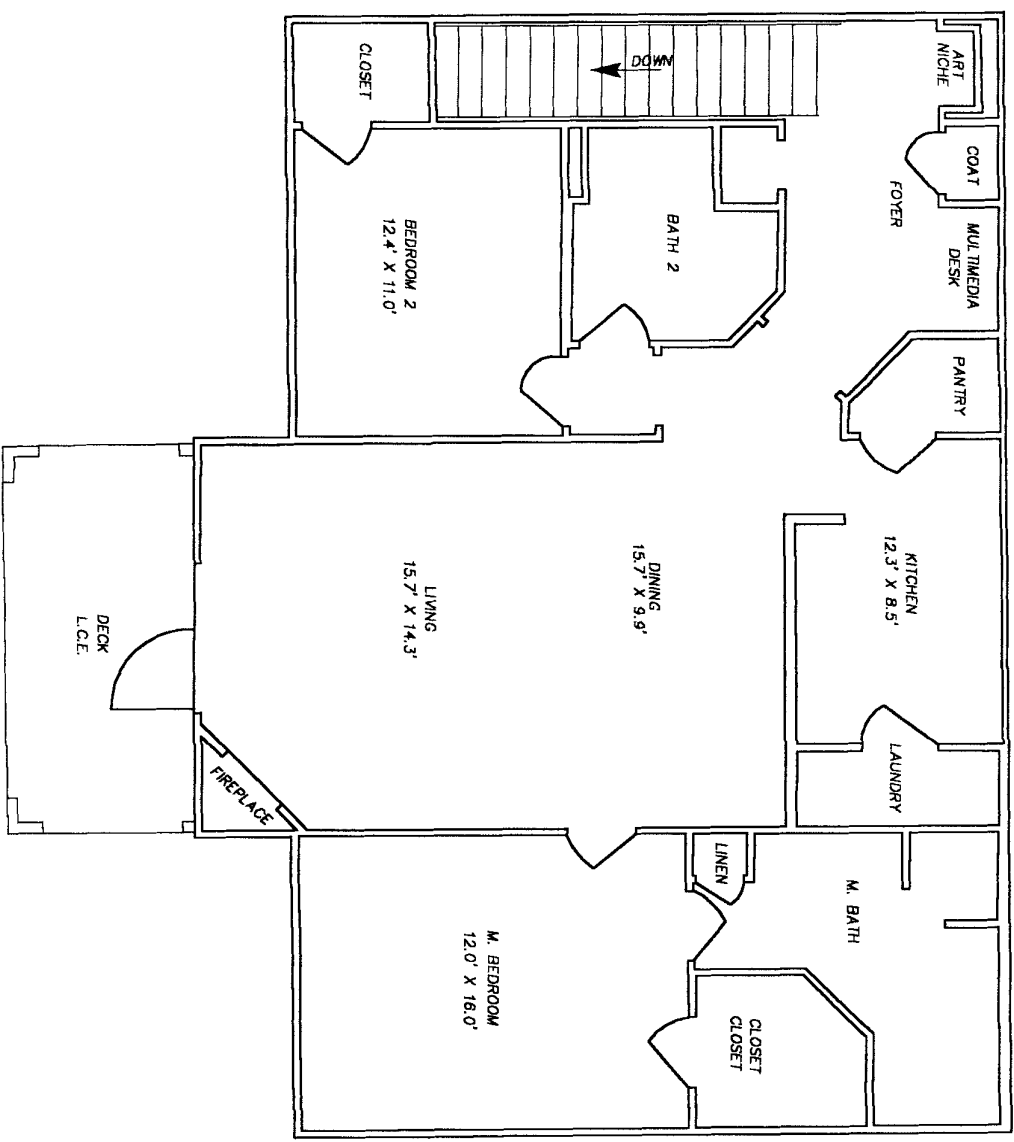

UNIT TYPE B1C FLOOR PLAN

RICHARD A. MILLER & ASSOCIATES
 PROFESSIONAL LAND SURVEYORS
 6701 BEACH BLVD. SUITE 100
 JACKSONVILLE, FLORIDA 32225
 (904) 721-5758 (FAX)
 (904) 721-1226 (TEL)

AUGUST 25, 2005

SHEET: 7 OF 16

HERITAGE DEERWOOD, A CONDOMINIUM

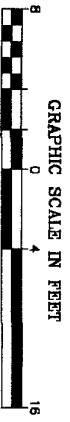

- APPLIES TO
- | | |
|------------|------------|
| UNIT #308 | UNIT #1108 |
| UNIT #408 | UNIT #1908 |
| UNIT #508 | UNIT #2208 |
| UNIT #608 | UNIT #2308 |
| UNIT #708 | UNIT #2408 |
| UNIT #808 | UNIT #2508 |
| UNIT #908 | UNIT #2608 |
| UNIT #1008 | UNIT #2708 |

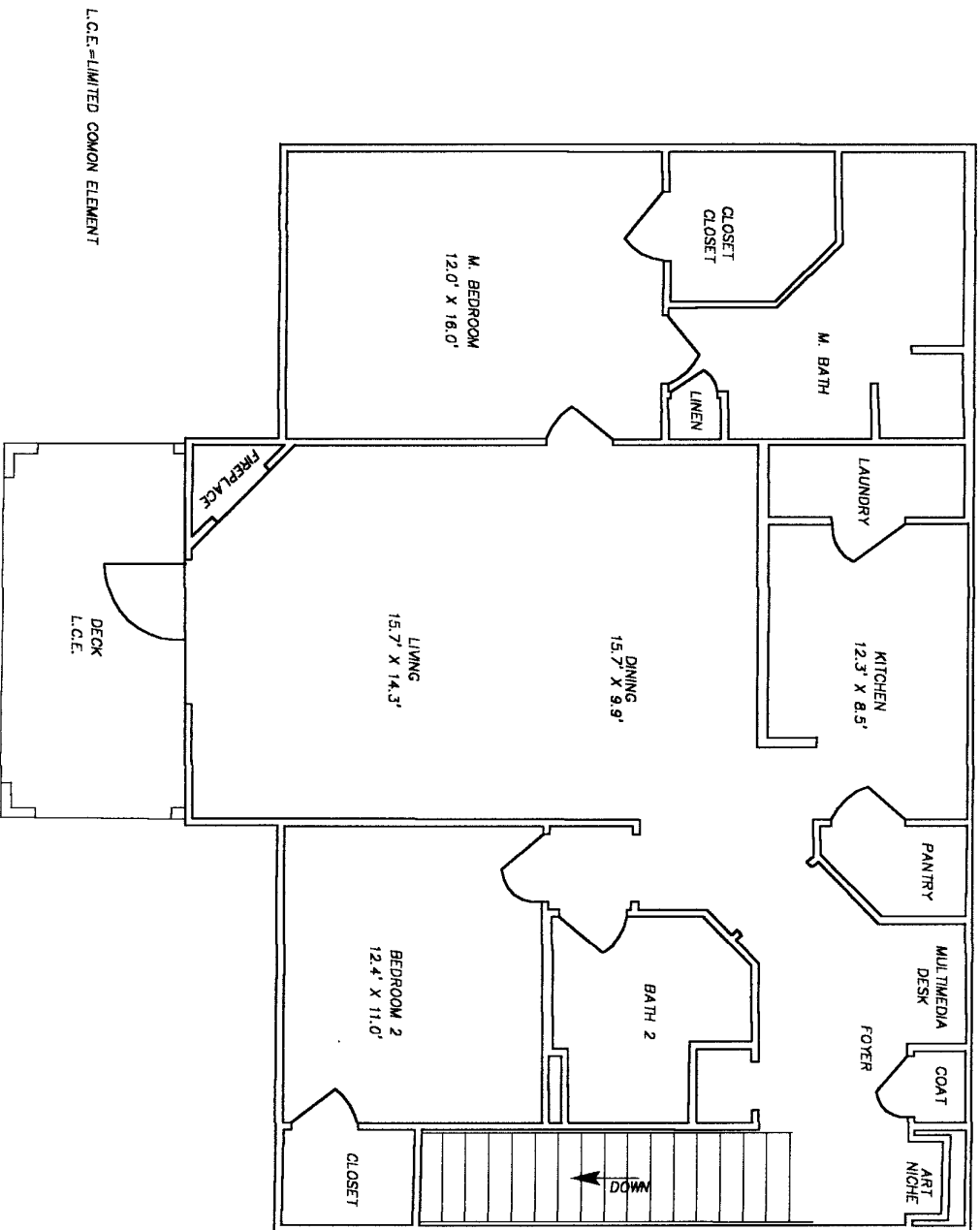

RICHARD A. MILLER & ASSOCIATES
 PROFESSIONAL LAND SURVEYORS
 6701 BEACH BLVD., SUITE 100
 JACKSONVILLE, FLORIDA 32225
 (904) 721-5758 (FAX)
 (904) 721-1226 (TEL)

UNIT TYPE B1C REVERSE FLOOR PLAN



HERITAGE DEERWOOD, A CONDOMINIUM

L.C.E. = LIMITED COMMON ELEMENT

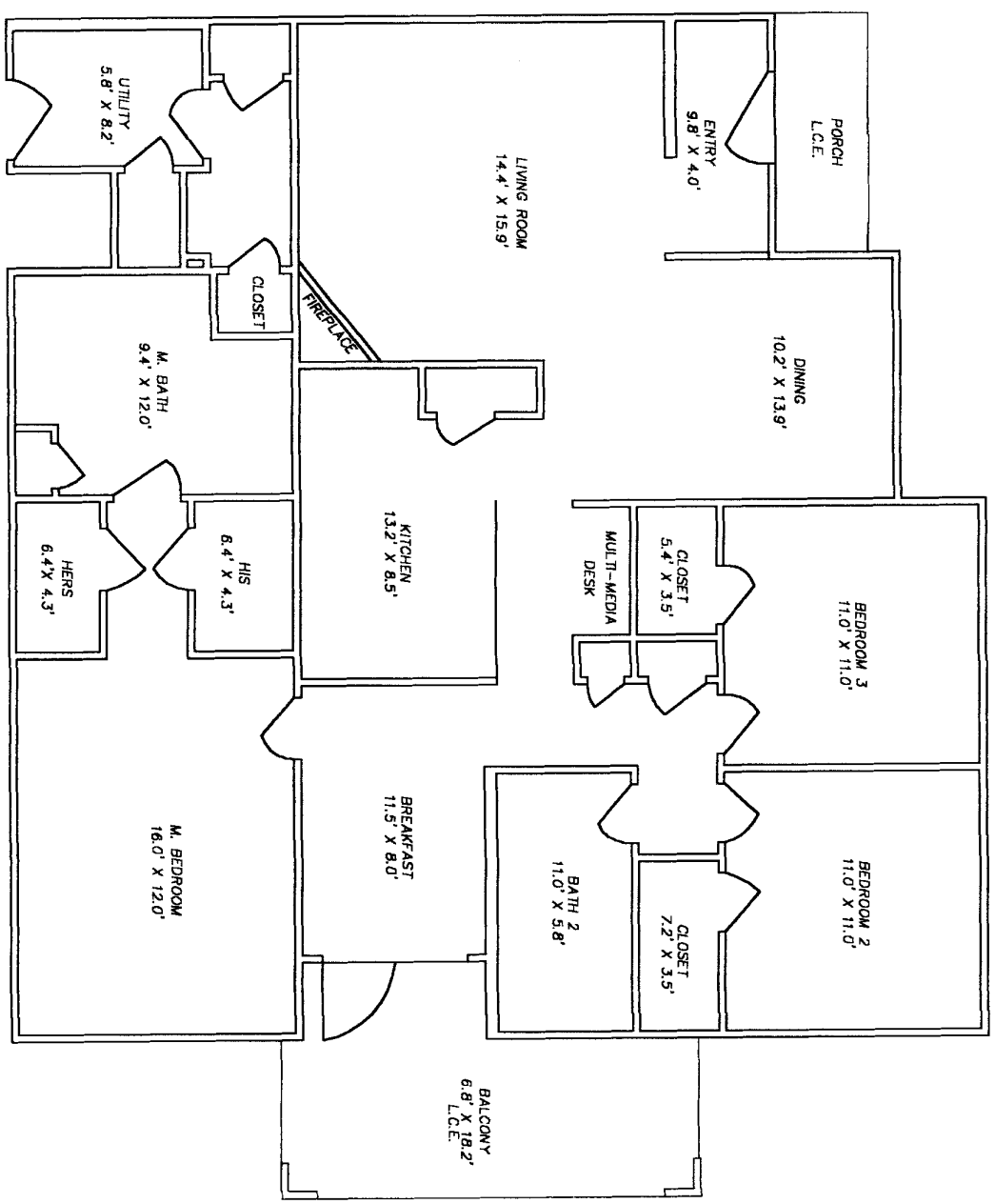

APPLIES TO	
UNIT #302	UNIT #1702
UNIT #502	UNIT #1802
UNIT #702	UNIT #2002
UNIT #902	UNIT #2102
UNIT #1102	UNIT #2302
UNIT #1202	UNIT #2502
UNIT #1502	UNIT #2602
UNIT #1602	

RICHARD A. MILLER & ASSOCIATES
 PROFESSIONAL LAND SURVEYORS
 6701 BEACH BLVD, SUITE 100
 JACKSONVILLE, FLORIDA 32225
 (904) 721-5758 (FAX)
 (904) 721-1226 (TEL)

UNIT TYPE C1A FLOOR PLAN

AUGUST 25, 2005

SHEET: 9 OF 16



HERITAGE DEERWOOD, A CONDOMINIUM

L.C.E. = LIMITED COMMON ELEMENT

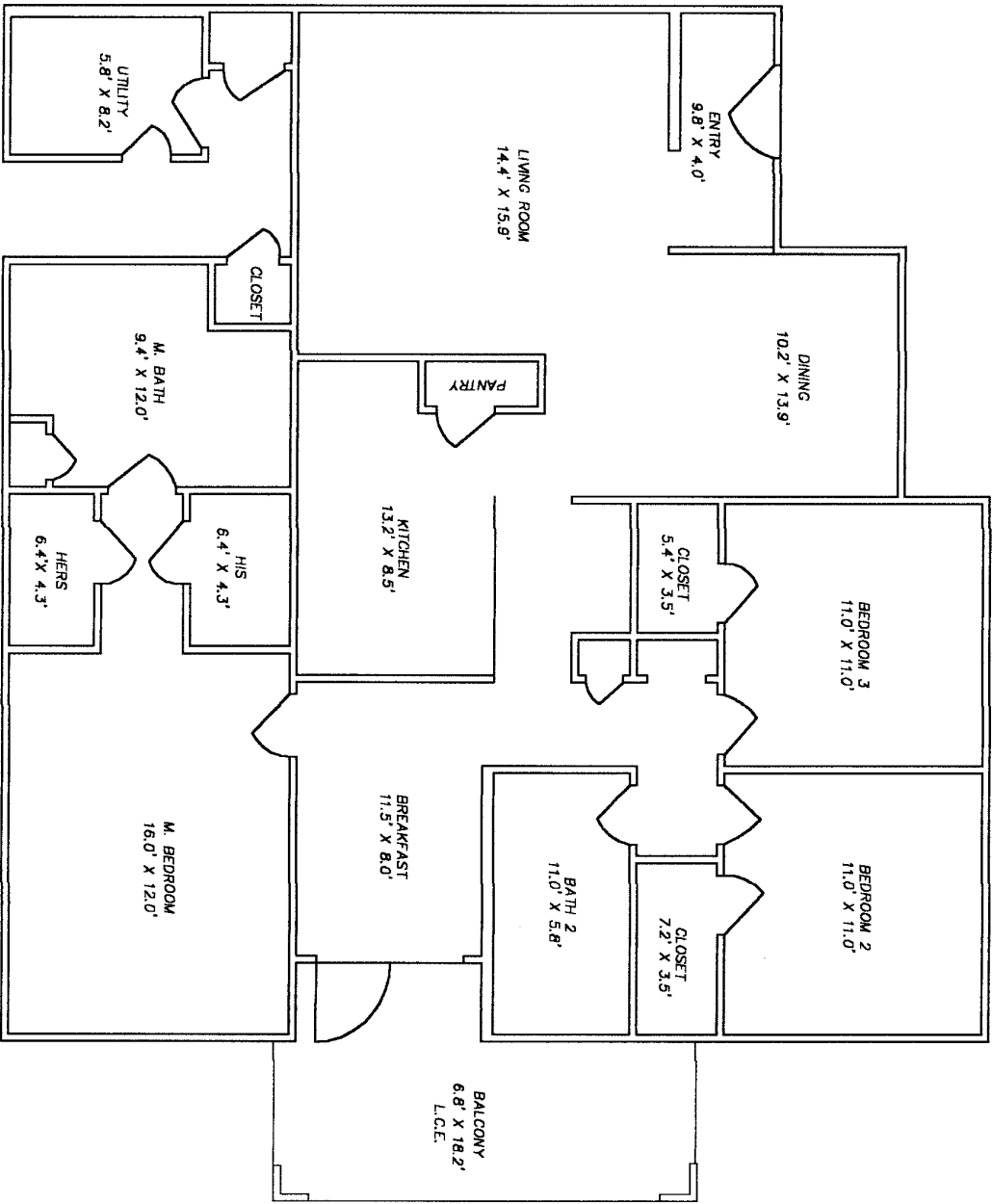

UNIT #	APPLIES TO
UNIT #304	UNIT #1704
UNIT #504	UNIT #1804
UNIT #704	UNIT #2004
UNIT #904	UNIT #2104
UNIT #1104	UNIT #2304
UNIT #1204	UNIT #2504
UNIT #1504	UNIT #2604
UNIT #1604	

RICHARD A. MILLER & ASSOCIATES
 PROFESSIONAL LAND SURVEYORS
 6701 BEACH BLVD. SUITE 100
 JACKSONVILLE, FLORIDA 32225
 (904) 721-5758 (FAX)
 (904) 721-1226 (TEL)

UNIT TYPE C1B FLOOR PLAN

AUGUST 25, 2005

SHEET: 10 OF 16

HERITAGE DEERWOOD, A CONDOMINIUM

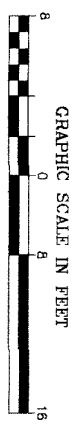

APPLIES TO

- UNIT #309 UNIT #1701
- UNIT #509 UNIT #1801
- UNIT #709 UNIT #2001
- UNIT #909 UNIT #2101
- UNIT #1109 UNIT #2309
- UNIT #1201 UNIT #2509
- UNIT #1501 UNIT #2609
- UNIT #1601

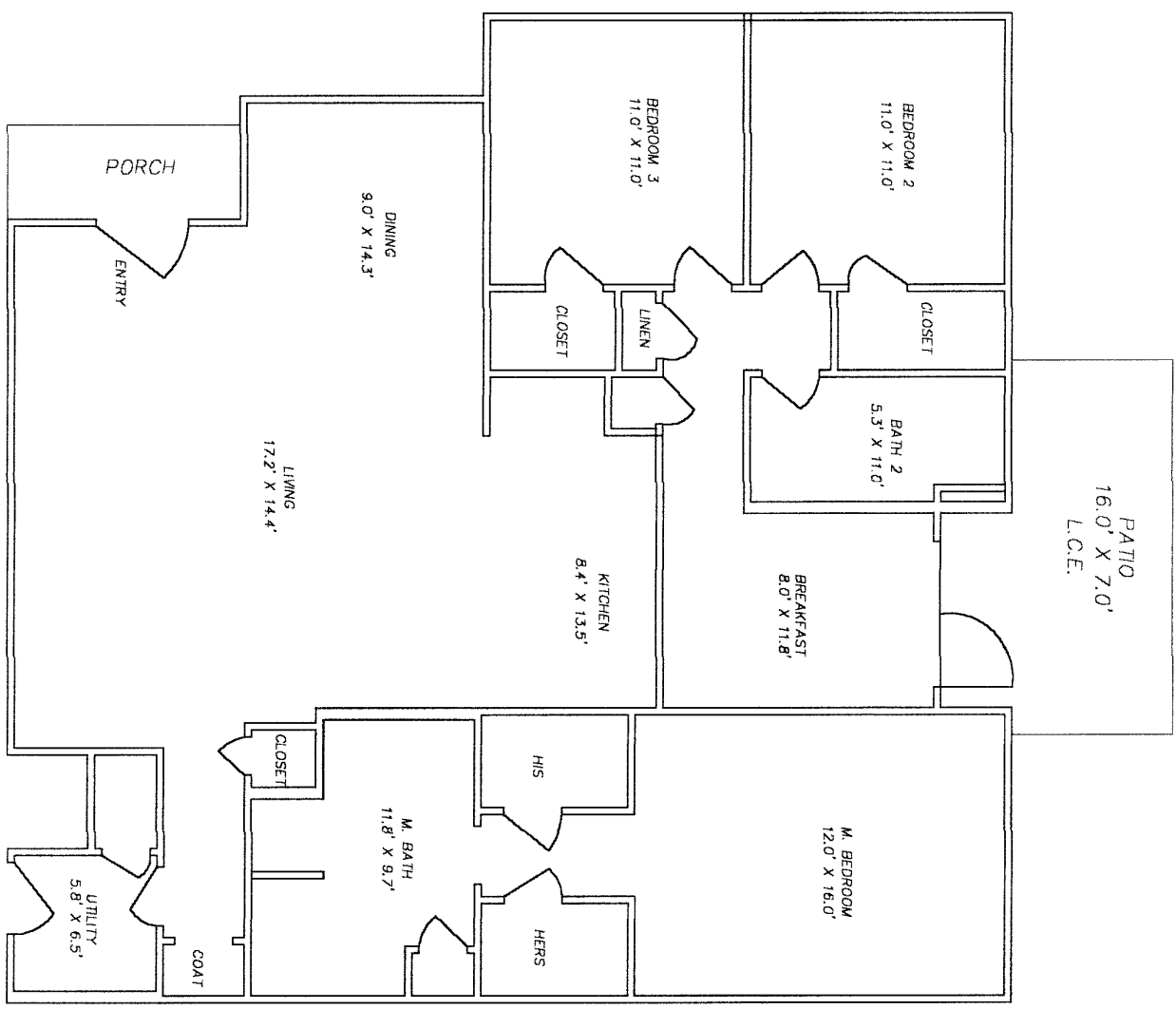

L.C.E. = LIMITED COMMON ELEMENT

RICHARD A. MILLER & ASSOCIATES
 PROFESSIONAL LAND SURVEYORS
 6701 BEACH BLVD. SUITE 100
 JACKSONVILLE, FLORIDA 32225
 (904) 721-5758 (FAX)
 (904) 721-1226 (TEL)

UNIT TYPE C1C FLOOR PLAN

AUGUST 25, 2005

SHEET: 11 OF 16

HERITAGE DEERWOOD, A CONDOMINIUM

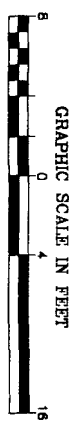

APPLIES TO

- | | |
|------------|------------|
| UNIT #307 | UNIT #1703 |
| UNIT #507 | UNIT #1803 |
| UNIT #707 | UNIT #2003 |
| UNIT #907 | UNIT #2103 |
| UNIT #1107 | UNIT #2307 |
| UNIT #1203 | UNIT #2507 |
| UNIT #1503 | UNIT #2607 |
| UNIT #1803 | |

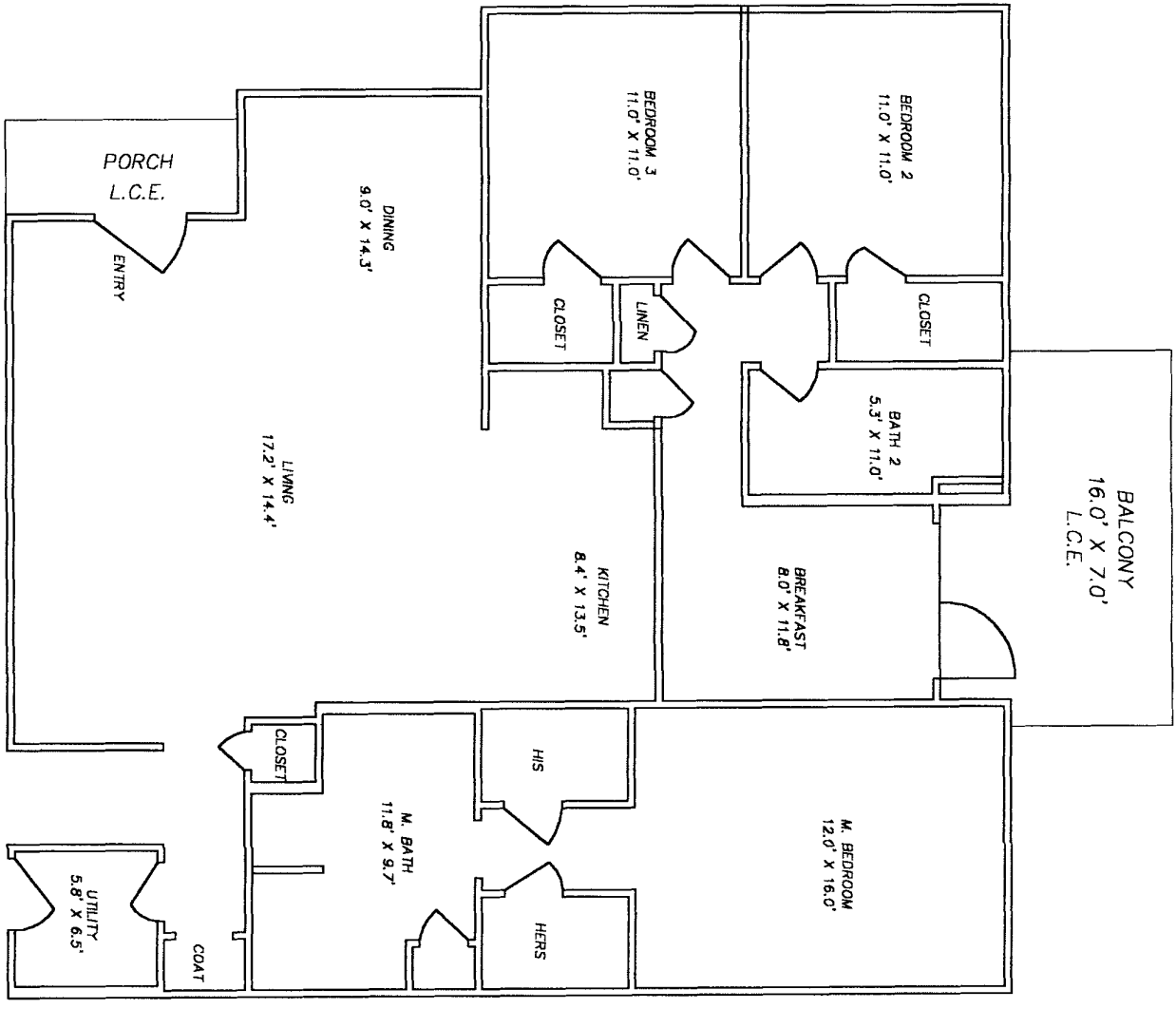

L.C.E. = LIMITED COMMON ELEMENT

RICHARD A. MILLER & ASSOCIATES
 PROFESSIONAL LAND SURVEYORS
 6701 BEACH BLVD, SUITE 100
 JACKSONVILLE, FLORIDA 32225
 (904) 721-5758 (FAX)
 (904) 721-1226 (TEL)

UNIT TYPE C1D FLOOR PLAN

AUGUST 25, 2005

SHEET: 12 OF 16

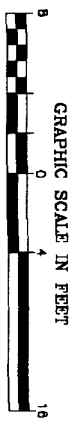

HERITAGE DEERWOOD, A CONDOMINIUM

APPLIES TO
 UNIT #501
 UNIT #701
 UNIT #801
 UNIT #2401
 UNIT #2601

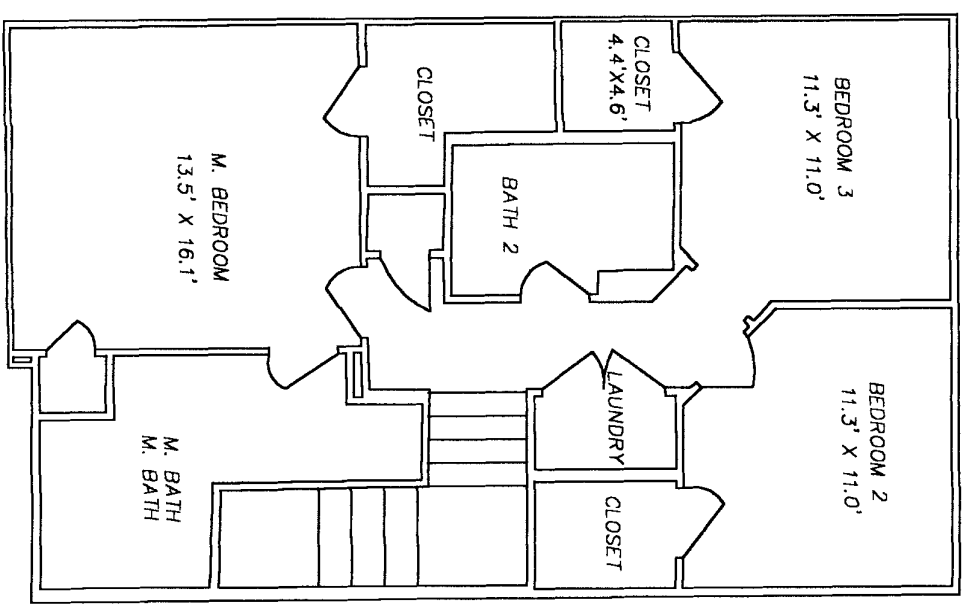

UNIT D1 SECOND FLOOR PLAN

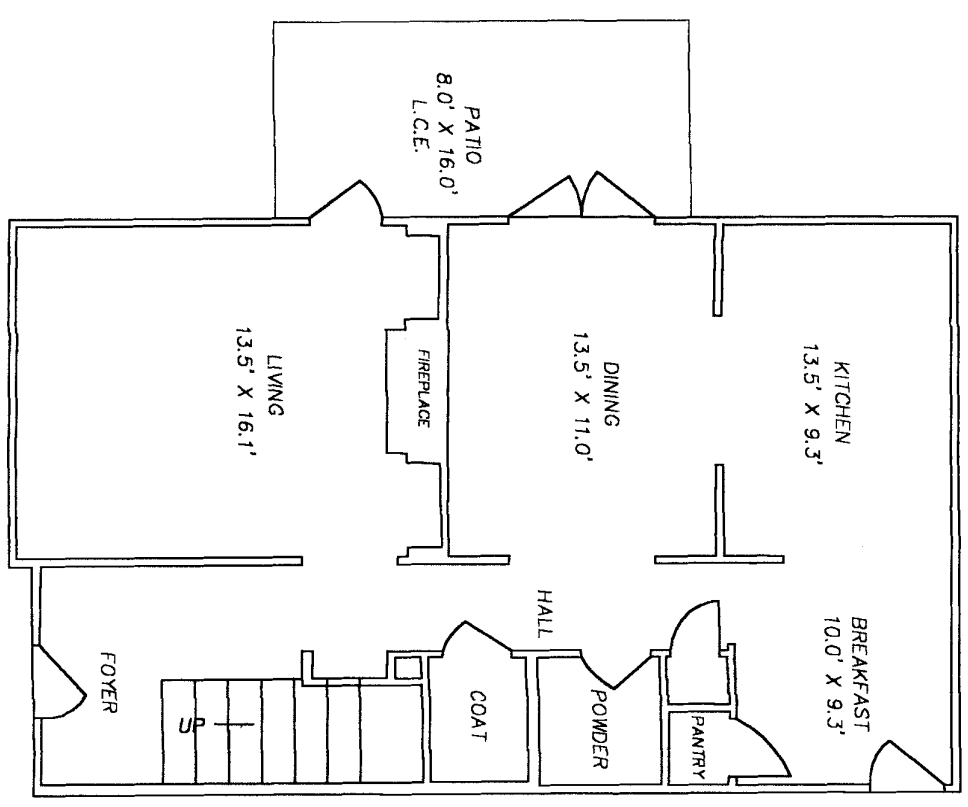

UNIT D1 FIRST FLOOR PLAN

L.C.E.=LIMITED COMMON ELEMENT

RICHARD A. MILLER & ASSOCIATES
 PROFESSIONAL LAND SURVEYORS
 6701 BEACH BLVD., SUITE 100
 JACKSONVILLE, FLORIDA 32225
 (904) 721-5758 (FAX)
 (904) 721-1226 (TEL)

UNIT TYPE D1 FLOOR PLAN

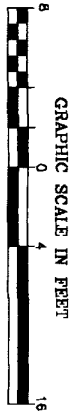

HERITAGE DEERWOOD, A CONDOMINIUM

APPLIES TO
UNIT #503
UNIT #703
UNIT #803
UNIT #2403
UNIT #2603

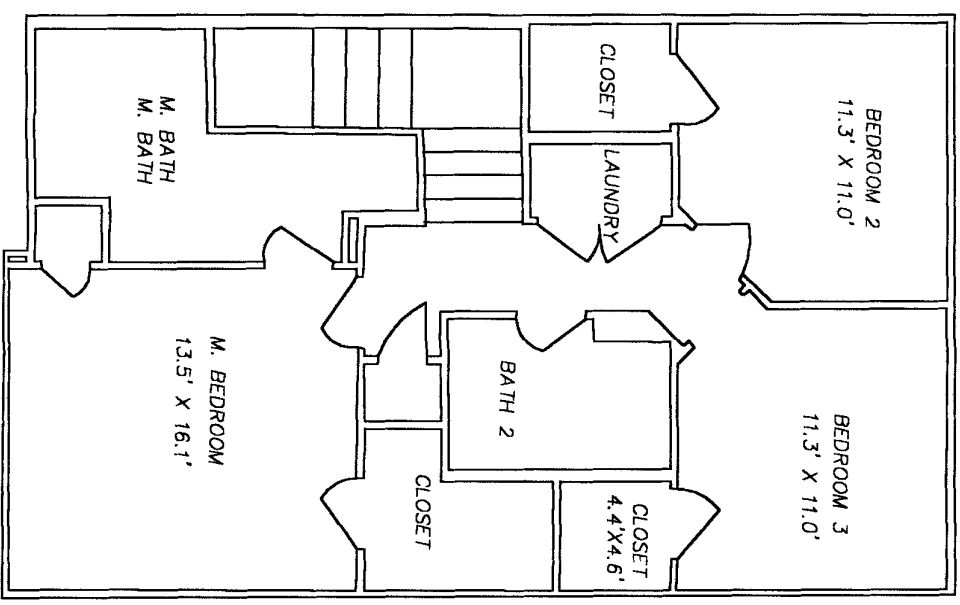

UNIT D1 SECOND FLOOR PLAN

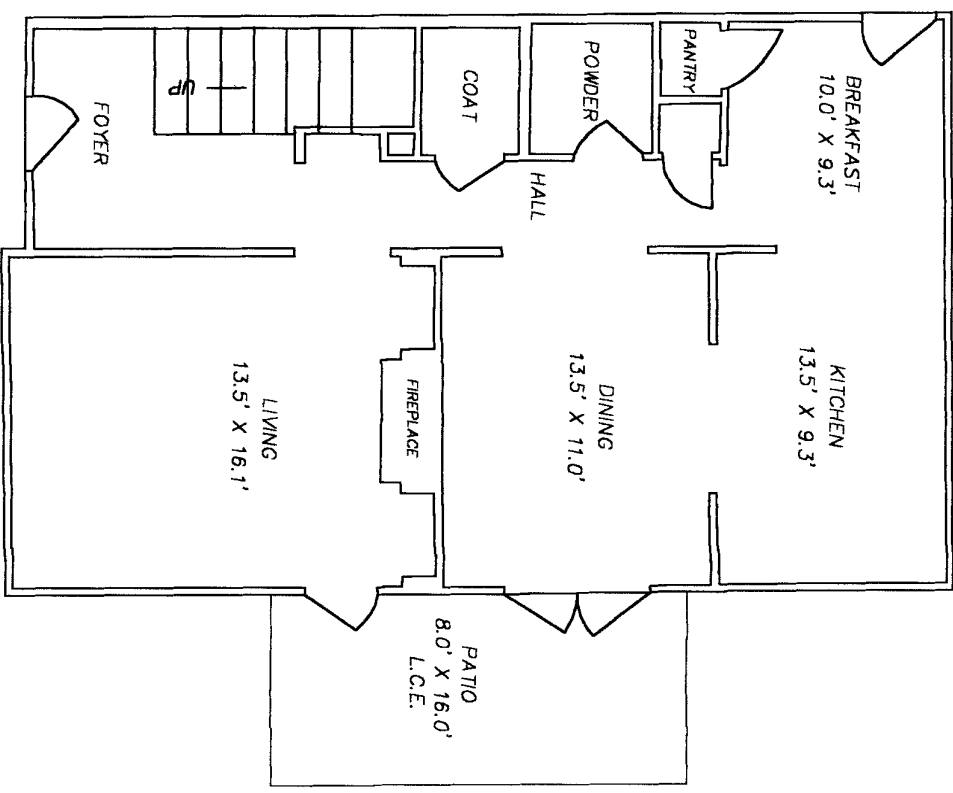

UNIT D1 FIRST FLOOR PLAN

UNIT TYPE D1 REVERSE FLOOR PLAN

RICHARD A. MILLER & ASSOCIATES
PROFESSIONAL LAND SURVEYORS
6701 BEACH BLVD, SUITE 100
JACKSONVILLE, FLORIDA 32225
(904) 721-5738 (FAX)
(904) 721-1226 (TEL)

AUGUST 25, 2005

SHEET: 14 OF 16

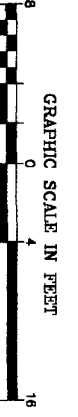

HERITAGE DEERWOOD, A CONDOMINIUM

APPLIES TO

- | | |
|------------|------------|
| UNIT #301 | UNIT #2201 |
| UNIT #401 | UNIT #2301 |
| UNIT #501 | UNIT #2401 |
| UNIT #901 | UNIT #2501 |
| UNIT #1001 | UNIT #2601 |
| UNIT #1101 | UNIT #2701 |
| UNIT #1901 | |

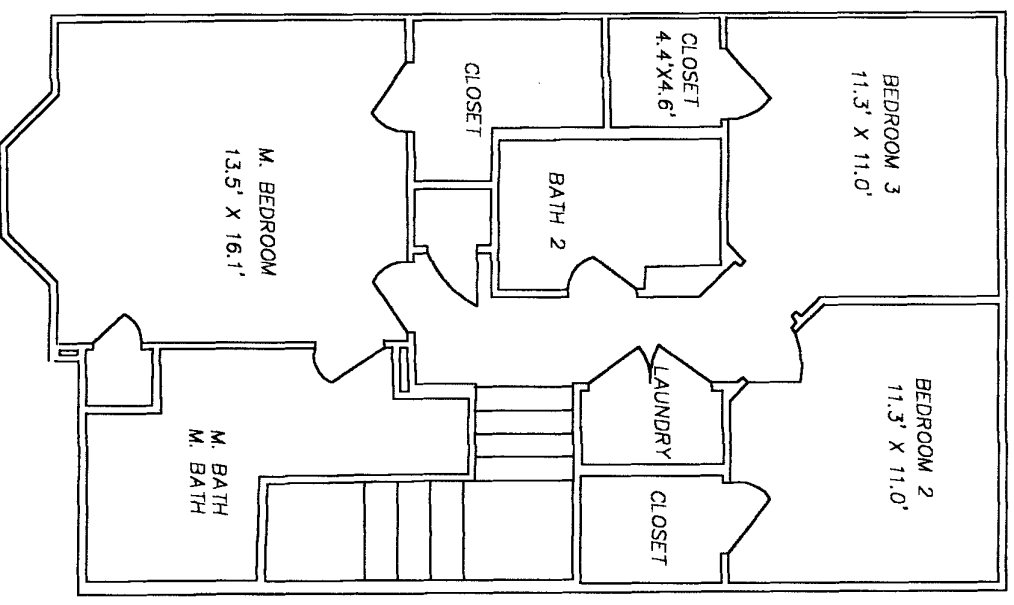

UNIT D2 SECOND FLOOR PLAN

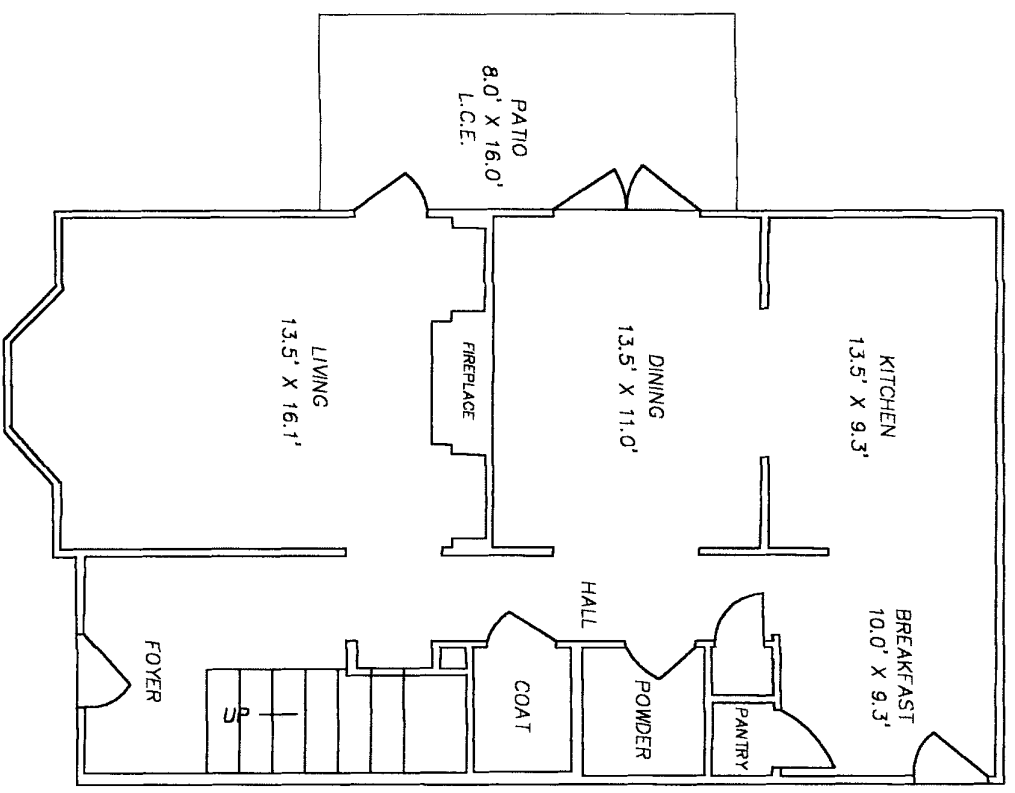

UNIT D2 FIRST FLOOR PLAN

L.C.E.=LIMITED COMMON ELEMENT

RICHARD A. MILLER & ASSOCIATES
 PROFESSIONAL LAND SURVEYORS
 6701 BEACH BLVD, SUITE 100
 JACKSONVILLE, FLORIDA 32225
 (904) 721-5758 (FAX)
 (904) 721-1226 (TEL)

UNIT TYPE D2 FLOOR PLAN

AUGUST 25, 2005

SHEET: 15 OF 16

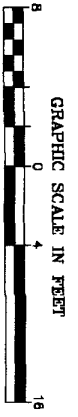

HERITAGE DEERWOOD, A CONDOMINIUM

- UNIT #303 UNIT #2203
 UNIT #403 UNIT #2303
 UNIT #603 UNIT #2403
 UNIT #903 UNIT #2503
 UNIT #1003 UNIT #2603
 UNIT #1103 UNIT #2703
 UNIT #1903

APPLIES TO

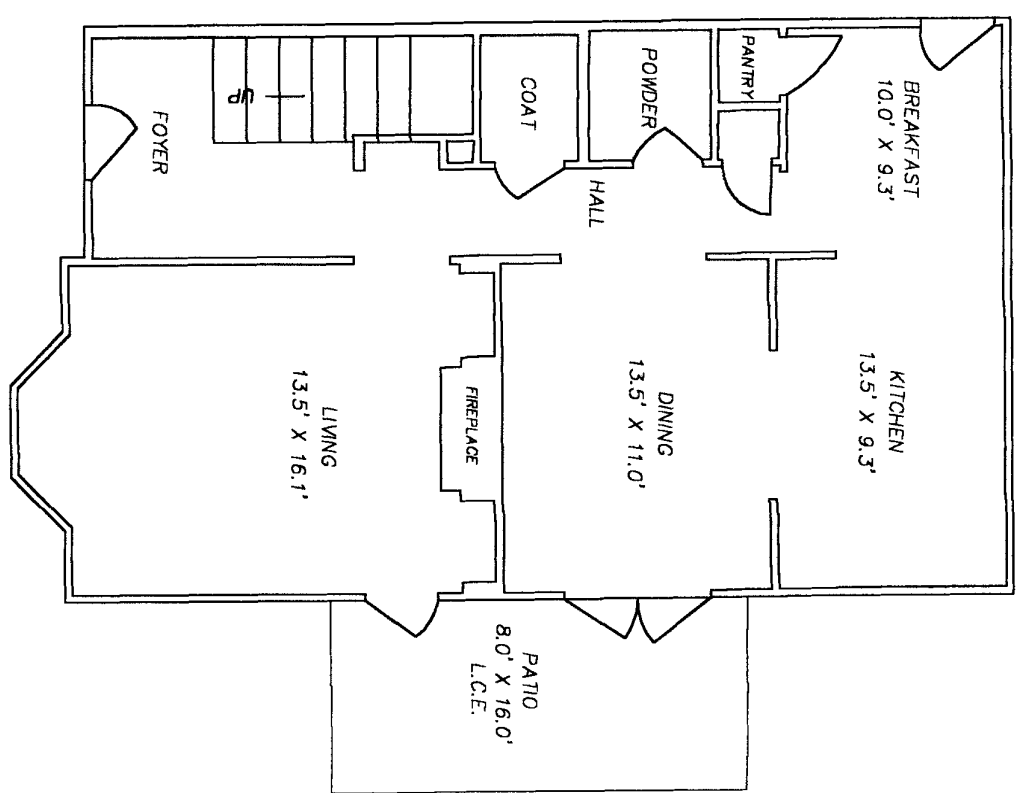
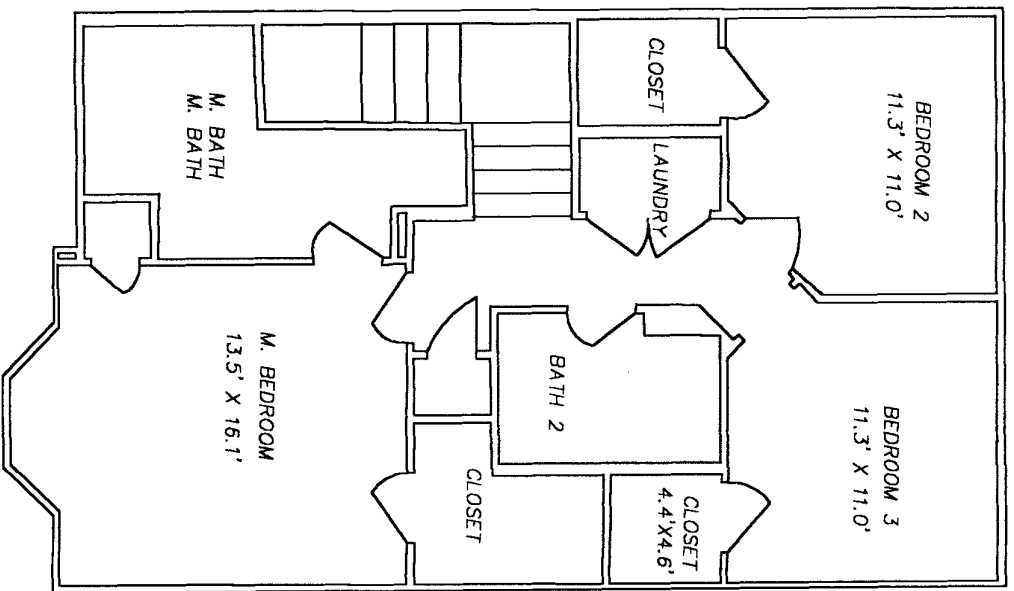

RICHARD A. MILLER & ASSOCIATES
 PROFESSIONAL LAND SURVEYORS
 6701 BEACH BLVD, SUITE 100
 JACKSONVILLE, FLORIDA 32225
 (904) 721-5758 (FAX)
 (904) 721-1226 (TEL)

EXHIBIT "C"

State of Florida



Department of State

I certify the attached is a true and correct copy of the Articles of Incorporation of HERITAGE DEERWOOD CONDOMINIUM ASSOCIATION, INC., a Florida corporation, filed on December 22, 2005, as shown by the records of this office.

The document number of this corporation is N05000012837.

Given under my hand and the
Great Seal of the State of Florida
at Tallahassee, the Capitol, this the
Twenty-third day of December, 2005

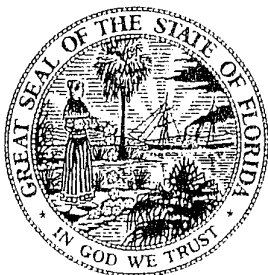

CR2EO22 (11-05)

David L. Mann
Secretary of State

ARTICLES OF INCORPORATION

OF

HERITAGE DEERWOOD CONDOMINIUM ASSOCIATION, INC.

(A FLORIDA NOT-FOR-PROFIT CORPORATION)

RECORDED 22 MAR 1995
STATE OF FLORIDA

**ARTICLE I
NAME**

The name of this corporation is Heritage Deerwood Condominium Association, Inc. (the "Association").

**ARTICLE II
INITIAL PRINCIPAL OFFICE AND MAILING ADDRESS**

The initial principal office and mailing address of the Association is 10901 Burnt Mill Road, Jacksonville, Florida 32256.

**ARTICLE III
PURPOSE**

The purpose for which the Association is organized is to act as the governing association of that certain condominium known as Heritage Deerwood, a Condominium (the "Condominium").

**ARTICLE IV
MEMBERS**

The qualification of members and the manner of their admission shall be as follows: Any approved person or persons who hold title in fee simple to a unit in the Condominium shall by virtue of such ownership be a member of the Association. Provided however, that transfer of membership shall be made only as a part of and incident to the transfer of ownership of a Condominium Unit ("Unit") with such transfers being subject to and controlled by the transfer procedures set forth in the Declaration of Condominium (the "Declaration"). After receiving approval of the Association required by the Declaration, change of membership in the Association shall be established by recording in the Public Records of Duval County, Florida, a deed or other instrument establishing record title to a unit in the Condominium and the delivery of a copy of the recorded instrument to the Association within a reasonable time following such recordation. Such delivery is not required for initial conveyances by Heritage Deerwood Condominium, LLC, a Delaware limited liability company, its successors and assigns, as the developer of the Condominium ("Developer"). The owner designated by such instrument thereby becomes a member of the Association and the membership of the previous owner is thereby terminated.

**ARTICLE V
CORPORATE EXISTENCE**

The Association shall exist perpetually.

**ARTICLE VI
INCORPORATOR**

The name and address of the incorporator is as follows:

Todd Caplin
1500 San Remo Avenue, Suite 201
Coral Gables, Florida 33146

The rights and interests of the incorporator shall automatically terminate when these Articles are filed with the Secretary of State.

**ARTICLE VII
DIRECTORS**

The property, business and affairs of the Association shall be managed by a board of directors (collectively the "Board of Directors") elected or appointed in the manner provided by the By-Laws. The number of directors shall be determined in the manner provided by the By-Laws, but which shall consist of not less than three (3) directors.

**ARTICLE VIII
AMENDMENTS**

A. Notice. Notice of a proposed amendment shall be included in the notice of any meeting at which the proposed amendment is to be considered and shall be otherwise given in the time and manner provided in Chapter 617, Florida Statutes and in Chapter 718, Florida Statutes (the "Condominium Act"). Such notice shall contain the proposed amendment or a summary of the changes to be affected thereby.

B. Adoption. Amendments shall be proposed and adopted in the manner provided in Chapter 617, Florida Statutes and in the Condominium Act (the latter to control over the former to the extent provided for in the Condominium Act).

C. Amendment Limitation. No amendment shall make any changes in the qualifications for membership, nor in the voting rights or property rights of Unit Owners, nor any changes in Articles XI or XII of these Articles of Incorporation, without the approval in writing of all Unit Owners and the joinder of all record owners of mortgages upon Units. No amendment shall be made that is in conflict with the Condominium Act, the Declaration or the By-Laws, nor shall any amendment make any changes which would in any way affect any of the rights, privileges, powers or options herein provided in favor of or reserved to the Developer and/or Institutional First Mortgagees (as defined in the Declaration), unless the Developer and/or the Institutional First Mortgagees, as applicable, shall join in the execution of the amendment. No amendment to this Section shall be effective.

D. Developer Amendments. Notwithstanding anything herein contained to the contrary, to the extent lawful, the Developer may amend these Articles of Incorporation consistent with, or not prohibited by, the provisions of the Declaration allowing certain amendments to be effected by the Developer alone.

**ARTICLE IX
VOTES**

Each Unit in the Condominium shall have one full indivisible vote.

**ARTICLE X
POWERS**

The powers of the Association shall include and be governed by the following:

A. General. The Association shall have all of the common law and statutory powers of a not for profit corporation under the laws of Florida, except as expressly limited or restricted by the terms of these Articles, the Declaration of Condominium, the By-Laws or the Condominium Act.

B. Enumeration. The Association shall have all of the powers and duties set forth in the Condominium Act, except as limited by these Articles, the By-Laws and the Declaration of Condominium (to the extent that they are not in conflict with the Condominium Act), and all of the powers and duties reasonably necessary to operate the Condominium pursuant to the Declaration of Condominium and as more particularly described in the By-Laws, as they may be amended from time to time.

C. Limitation. The powers of the Association shall be subject to and shall be exercised in accordance with the provisions hereof and of the Declaration of Condominium, the By-laws and the Condominium Act, provided that in the event of conflict, the provisions of the Condominium Act shall control over those of the Declaration of Condominium and the By-Laws.

**ARTICLE XI
INDEMNIFICATION PROVISIONS**

The Association shall indemnify its directors, officers and committee members and may indemnify its employees and agents, to the fullest extent permitted by law against any and all expenses or liabilities incurred in defending civil, criminal or administrative proceedings resulting from the performance or attempted performance in good faith of their offices on behalf of the Association or its members. Such indemnification shall include advancement of expenses prior to the final disposition of any such proceedings and amounts paid in settlement of such proceedings, and such indemnification shall not be deemed exclusive of any other rights to which those indemnified may be entitled under any document other than these Articles, by vote of the members or disinterested directors, or otherwise. This indemnification shall continue as to a person who has ceased to be a director, officer, committee member, employee or agent, and shall inure to the benefit of his or her heirs and personal representatives.

**ARTICLE XII
DISTRIBUTION OF INCOME; DISSOLUTION**

The Association shall not pay a dividend to its members and shall make no distribution of income to its members, directors or officers, and upon dissolution, all assets of the Association shall be transferred only to another nonprofit corporation or a public agency or as otherwise authorized by the Florida Not For Profit Corporation Act (Chapter 617, Florida Statutes).

**ARTICLE XIII
REGISTERED AGENT**

The name of the registered agent and place for service of process shall be Todd Caplin, whose address is: 1500 San Remo Avenue, Suite 201, Coral Gables, Florida 33146.

IN WITNESS WHEREOF, the undersigned subscriber has executed these Articles of Incorporation this 19th day of December, 2005.



Todd Caplin

ACCEPTANCE OF REGISTERED AGENT

Having been named to accept service of process for the above stated corporation, at the place designated in these Articles of Incorporation, I hereby agree to act in this capacity, and I further agree to comply with the provisions of all statutes relative to the proper and complete performance of my duties.



Todd Caplin

2005 DEC 22 AM 11:25
TALLAHASSEE FLORIDA

EXHIBIT "D"**BY-LAWS****OF****HERITAGE DEERWOOD CONDOMINIUM ASSOCIATION, INC.****1. GENERAL.**

1.1. IDENTITY. These are the By-Laws of Heritage Deerwood, a Condominium, a Florida not-for-profit corporation formed for the purpose of administering Heritage Deerwood, a Condominium (the "Condominium"), which will be located in Jacksonville, Duval County, Florida, upon the property described in Exhibit "A" to the Declaration of Condominium of Heritage Deerwood, a Condominium (the "Declaration"). (The corporation shall hereafter be referred to as the "Association.") Capitalized terms not otherwise defined in these By-Laws shall have the meaning ascribed to such terms in the Declaration.

1.2. OFFICE. The office of the Association shall be at the Condominium or such other location within Duval County, Florida, as may from time to time be determined by the Board of Directors.

1.3. FISCAL YEAR. The fiscal year of the Association shall be the calendar year, unless otherwise determined by the Board of Directors.

1.4. SEAL. The seal of the Association shall be circular in shape, bear the abbreviated name of the Association, the word "Florida," and the year of establishment, 2005.

2. VOTING.

2.1. NUMBER OF VOTES. The Unit Owner or Unit Owners of fee simple title of record for each Unit shall have one (1) indivisible vote per Unit ("Voting Interest") in the Association as to matters on which a vote by the Unit Owners is taken as provided in the Condominium Documents and the Condominium Act. If a Unit Owner owns more than one Unit, the Voting Member for such Units shall be entitled to cast the number of votes for each Unit owned.

2.2. VOTING BY MULTIPLE OWNERS OR ENTITY. If a Unit is owned by more than one person, those persons (including husbands and wives) shall decide among themselves as to who shall act as the Voting Member for the Unit and the Voting Member shall be designated in a certificate signed by all record owners and filed with the Association. If a Unit is owned by more than one person and the co-Owners have elected not to file a certificate designating one of them as a Voting Member, the presence (in person or by proxy) of any one or all of them at a meeting of the Members shall be considered to be the presence of a Voting Member for purposes of determining whether a quorum has been attained at the meeting. If a dispute arises between the co-Owners as to how the vote shall be cast, they shall lose the right to cast their vote on the matter being voted upon, but their vote shall be continued to be counted for the purpose of determining the existence of a quorum. If a Unit is owned by a corporation, limited liability company, general partnership, limited partnership or trust, the Voting Member shall be designated by a certificate signed by an appropriate officer, partner, manager or member or trustee of the entity and filed with the Association. The person designated as the Voting Member need not be a Unit Owner. The certificate shall be filed with the Secretary of the Association. Those certificates shall be valid until revoked or until superseded by a subsequent certificate or until a

change in the ownership of the Unit concerned. A certificate designating the person entitled to cast the vote for a Unit may be revoked by any record owner of an undivided interest in the Unit. The person designated as the Voting Member need not be an Owner.

2.3. FAILURE TO FILE CERTIFICATE DESIGNATING THE VOTING MEMBER.

2.3.1. Unit Owners other than the Developer who were required but failed to file a certificate as provided in Section 2.2 shall not be considered Voting Members for purposes of determining whether a quorum has been attained at the meeting, nor shall such Unit Owners be permitted to vote at meetings of the Unit Owners on any issue.

2.3.2. If a Unit is owned by one person, the presence (in person or by proxy) of the Unit Owner at a meeting of the Unit Owners shall be considered to be the presence of a Voting Member for purposes of determining whether a quorum has been attained at the meeting. If a Unit is owned by more than one person and the co-Owners (including husbands and wives) have elected not to file a certificate designating one of them or another person as a Voting Member, the presence (in person or by proxy) of any one or more of them at a meeting of the Unit Owners shall be considered to be the presence of a Voting Member for purposes of determining whether a quorum has been attained at the meeting. If more than one of them are present (in person or by proxy), the votes of any one or more of them on any given issue voted upon at that meeting shall be considered the votes of a single Voting Member; provided, however, If a dispute arises between the co-Owners as to how the vote shall be cast, they shall lose the right to cast their vote on the matter being voted upon, but their vote shall be continued to be counted for the purpose of determining the existence of a quorum.

2.4. MAJORITY VOTE. The acts approved by a majority of the votes cast by Voting Members present in person or by proxy at a meeting at which a quorum has been attained shall be binding upon all Unit Owners for all purposes, except where otherwise provided by law, the Declaration, the Articles or these Bylaws. As used in these Bylaws, the Articles or the Declaration, the terms "majority of the Unit Owners" and "majority of the Voting Interests" shall mean a majority of the votes entitled to be cast by the Voting Members present in person or by proxy and voting at any meeting of the Unit Owners at which a quorum shall have been attained and shall not mean a majority of the Voting Members themselves or a majority of the total votes entitled to be cast by all Voting Members. Similarly, if some greater percentage of Voting Members is required herein or in the Declaration or Articles, it shall mean such greater percentage of the votes of Voting Members and not of the Voting Members themselves or of the total votes entitled to be cast by all Voting Members.

3. UNIT OWNERS' MEETINGS

3.1. ANNUAL MEETINGS. Annual meetings of the Unit Owners shall be held at the Condominium or at such other convenient location, as may be determined by the Board of Directors, no later than the month of April each year, for the purpose of the election of the Board of Directors and for transacting any business authorized to be transacted by the Unit Owners.

3.2. SPECIAL MEETINGS. Special meetings of the Unit Owners shall be held whenever called by the President, Vice President or by a majority of the Board of Directors and when requested by written petition signed and dated from at least twenty-five percent (25%) of the total Voting Interests. Such petition shall state the purpose(s) of the meeting. The business at a special meeting requested by petition shall be limited to the items specified in the petition and contained in the notice of the meeting. If the Board of Directors adopts a budget requiring assessments exceeding one hundred fifteen percent (115%) of the assessments for the preceding year and the Board of Directors receives,

within twenty-one (21) days after adoption of the annual budget, a written request from at least ten percent (10%) of the total Voting Interests, the Board of Directors shall call a special meeting of the Unit Owners to consider and enact a substitute budget. The determination as to whether the assessments exceed one hundred fifteen percent (115%) shall be made in accordance with Section 718.112 (2)(e) of the Condominium Act. Unit Owners' meetings to recall a member or members of the Board of Directors may be called by ten percent (10%) of the total Voting Interests. Electronic transmission may not be used as a method of giving notice of a meeting called in whole or in part for purpose of recalling a member or members of the Board of Directors.

3.3. NOTICE OF UNIT OWNERS' MEETINGS. Notice of any meeting of the Unit Owners, including the annual meeting (which must include an identification of agenda items), shall be mailed by United States mail, hand-delivered or electronically transmitted to each Unit Owner, unless waived in writing, at least fourteen (14) days prior to the meeting; provided, however, that any election at which one (1) or more of the Board of Directors are to be elected must be noticed as provided for in Section 3.4 and provided further, that electronic transmission may not be used as a method of giving notice of a meeting called in whole or in part for the purpose of recalling a member or members of the Board of Directors. If the notice is mailed, it shall be mailed to each Unit Owner at the address last furnished to the Association by the Unit Owner. However, if a Unit is owned by more than one person, the Association shall provide notice to that one address which the developer initially identifies for that purpose and thereafter as one or more of the owners of the Unit shall so advise the Association in writing, or if no address is given or if the owners of the Unit do not agree, to the address provided in the deed of record. An officer of the Association, or the manager or other person providing notice of the meeting, shall execute an affidavit of mailing or delivery, per Section 718.112(2)(d)(2) of the Condominium Act, or provide a United States Postal Certificate of Mailing which shall be retained in the official records of the Association as proof of such mailing or delivery. Written notice of the meeting shall also be posted in a conspicuous place on the Condominium Property at least fourteen (14) continuous days prior to the meeting. The Board of Directors, upon notice to Unit Owners, shall, by duly adopted rule, designate a specific location on the Condominium Property upon which all notices of Unit Owner meetings shall be posted; however, if there is no Condominium Property or Association Property upon which notices can be posted, this requirement does not apply. In lieu of or in addition to the physical posting of notice of any meeting of the Unit Owners on the Condominium Property, the Association may, by reasonable rule, adopt a procedure for conspicuously posting and repeatedly broadcasting the notice and the agenda on a closed-circuit cable television system serving the Association. However, if broadcast notice is used in lieu of a notice posted physically on the Condominium Property, the notice and agenda must be broadcast at least four times every broadcast hour of each day that a posted notice is otherwise required by this Section 3.3. When broadcast notice is provided, the notice and agenda must be broadcast in a manner and for a sufficient continuous length of time so as to allow an average reader to observe the notice and read and comprehend the entire content of the notice and the agenda.

3.4. BOARD ELECTION MEETINGS; NOTICE AND PROCEDURE. The regular or general election shall occur at the time and place at which the annual meeting is scheduled to occur, regardless of whether a quorum is present. Members of the Board of Directors shall be elected by written ballot.

3.4.1. Not less than sixty (60) days before a scheduled election, the Association shall mail, deliver or electronically transmit, whether by separate Association mailing or included in another Association mailing, delivery or transmission, including regularly published newsletters, to each Unit Owner entitled to vote, the first notice of the date of the election. It must contain the name and correct mailing address of the Association. Any Unit Owner or other eligible person desiring to be a candidate for the Board of Directors must give written notice to the Association not less than forty (40)

days before a scheduled election. Together with the written notice and agenda as set forth in Section 3.3, the Association shall mail, deliver or electronically transmit a second notice of the election to all Unit Owners entitled to vote therein, together with a written ballot which shall list all candidates. Upon request of a candidate, the Association shall include an information sheet which must be furnished by the candidate not less than thirty-five (35) days before the election, on one side of a sheet, no larger than 8½ inches by 11 inches, to be included with the mailing, delivery or transmission of the ballot, with the costs of copying and mailing, delivery or electronic transmission to be borne by the Association. The Association shall not edit, alter, or otherwise modify the content of the information sheet and shall have no liability for its contents.

3.4.2. A Unit Owner who needs assistance in voting, due to blindness, disability or inability to read or write, may obtain assistance from a member of the Board of Directors or other Unit Owner, but no Unit Owner shall permit another person to cast his or her ballot and any such ballots improperly cast shall be deemed invalid.

3.4.3. There is no quorum requirement, however, at least twenty percent (20%) of the eligible Voting Interests must cast a valid ballot to have a valid election of the members of the Board of Directors and elections shall be decided by a plurality of those votes cast.

3.4.4. An election and balloting are not required unless more candidates file notices of intent to run or are nominated than vacancies exist on the Board of Directors.

3.4.5. Notwithstanding anything to the contrary in this Section 3, the Association may, by the affirmative vote of a majority of the total Voting Interests, provide for different voting and election procedures than set forth in these By-Laws which vote may be by a proxy specifically delineating the different voting and election procedures. The different voting and election procedures may provide for elections to be conducted by limited or general proxy.

3.5. NOTICE; OWNERS BUDGET MEETING. Notice of a special meeting called by the Board of Directors pursuant to Section 718.112(e) of the Condominium Act at the written request of ten percent (10%) of the Unit Owners received within twenty-one (21) days after adoption of an annual budget because of a budget exceeding one hundred fifteen percent (115%) of that of the preceding year requires not less than fourteen (14) days' written notice to each Unit Owner.

3.6. NOTICES SPECIFIC. All notices of meetings shall state clearly and particularly the time, place, and purpose or purposes of the meeting and shall incorporate an identification of agenda items.

3.7. QUORUM. A quorum at meetings of the Unit Owners shall consist of a majority of the Voting Interests of the entire membership. Decisions made by a majority of the Voting Interests represented at a meeting, at which a quorum is present in person or by proxy, shall be binding and sufficient for all purposes except such decisions as may be required by the Condominium Act, or the Condominium Documents require a larger percentage in which case the percentage required in the Condominium Act or the Condominium Documents shall govern.

3.8. OWNER PARTICIPATION. Unit Owners shall have the right to participate in meetings of Unit Owners with reference to all designated agenda items. However, the Association may adopt reasonable rules governing the frequency, duration and manner of Unit Owner participation. Any Unit Owner may tape record or videotape a meeting of the Unit Owners subject and pursuant to rules adopted from time to time by the Division of Florida Land Sales, Condominiums and Mobile Homes.

3.9. INDIVISIBLE VOTE. Each Unit shall have one indivisible vote. If multiple owners of a Unit cannot agree on a vote, the vote shall not be counted.

3.10. PROXIES. Votes may be cast in person or by proxy. Proxies shall be in writing, signed and dated and shall be valid only for the particular meeting designated therein or an adjournment thereof, but in no event for more than ninety (90) days, and must be filed with the Secretary before or at the voter registration immediately preceding the meeting. Except as specifically otherwise provided in this Section, or by the Condominium Act from time to time, Unit Owners may not vote by general proxy, but may vote by limited proxies substantially conforming to the limited proxy form adopted by the Division of Florida Land Sales, Condominiums and Mobile Homes. Both limited proxies and general proxies may be used to establish a quorum. Limited proxies shall be used for votes taken to waive or reduce reserves; for votes taken to waive financial reporting requirements of the Condominium Act; for votes taken to amend the Declaration; for votes taken to amend the Articles of Incorporation or By-Laws; and for any other matter which the Condominium Act requires or permits a vote of the Unit Owners. No proxy, limited or general, shall be used in the election of Board members unless otherwise permitted by Florida Administrative Code Rule 61B-23.0026(2)(d). General proxies may be used for other matters for which limited proxies are not required, and may also be used in voting for non-substantive changes to items for which a limited proxy is required and given.

3.11. NO QUORUM. If any meeting of Unit Owners cannot be organized because a quorum is not present, the Unit Owners who are present, either in person or by proxy, may adjourn the meeting from time to time until a quorum is present.

3.12. ORDER OF BUSINESS. The order of business at annual meetings of the Unit Owners and, as far as applicable at all other meetings of the Unit Owners, may be:

- (a) Collection of ballots.
- (b) Checking of signatures and unit identifications on ballot outer envelopes against the eligible voter lists.
- (c) Registering proxies and counting votes.
- (d) Proof of Notice of meeting or waiver of notice.
- (e) Calling of the roll.
- (f) Reading and disposal of any unapproved minutes.
- (g) Reports of the Board of Directors.
- (h) Reports of Committees.
- (i) Announcement of the results of the election of Board members.
- (j) Unfinished business.
- (k) New business.
- (l) Adjournment.

4. BOARD OF DIRECTORS

4.1. NUMBER OF DIRECTORS. The affairs of the Association shall be governed initially by a Board of Directors composed of three (3) persons (the "First Board") appointed by the Developer. The Developer-appointed Board members may be, at the Developer's option, expanded to five (5) persons. The Board of Directors, after turnover of control by the Developer, may consist of three (3) or five (5) persons, as may be determined from time to time by the Voting Interests of the Association.

4.2. QUALIFICATIONS. A Director must be a natural person of at least eighteen (18) years of age, but need not be a citizen of the United States of America. All non-Developer Board members shall be Unit Owners or spouses of Unit Owners, or a shareholder, officer, partner or director of a Unit Owner. All officers of a corporation, trust, partnership or other such owner shall be deemed to be Unit Owners so as to be eligible for Board of Directors' membership. Any person who has been convicted of any felony by any court of record in the United States and who has not had his or her right to vote restored pursuant to law in the jurisdiction of his or her residence is not eligible for Board membership (provided, however, that the validity of any Board action is not affected if it is later determined that a member of the Board is ineligible for Board membership due to having been convicted of a felony).

4.3. ELECTION OF DIRECTORS.

4.3.1. Subject to the rights of the Developer to appoint members of the Board of Directors as stated, the Board of Directors shall be elected by the Voting Interests at the time and place at which the annual meeting is scheduled to occur regardless of whether a quorum is present.

4.3.2. Until such time as the Unit Owners other than the Developer are entitled to elect one or more members of the Board of Directors as provided below, the Developer shall be entitled to designate and appoint all successor Directors to serve on the First Board. Directors appointed by Developer shall not be required to be owners or residents of Units in the Condominium. The Developer reserves the right to remove any Director appointed by the Developer and the right to remove any Director designated by the Developer in accordance with these By-Laws. Any successor of Developer designated in the manner provided in the Declaration shall be entitled to the rights of Developer stated in this paragraph.

4.3.3. When Unit Owners other than the Developer own fifteen percent (15%) or more of the Units of the Condominium, the Unit Owners other than Developer shall be entitled to elect no less than one third of the members of the Board of Directors. The Developer shall designate the remaining members of the Board of Directors. The director to be elected by the Unit Owners other than the Developer and the remaining directors to be designated by the Developer are subsequently collectively referred to as the "Initial Elected Board" and shall succeed the First Board upon their election and qualification. Subject to the provisions of Subsection 4.3.4 below, the Initial Elected Board shall serve until the next annual members' meeting, whereupon the directors shall be designated and elected in the same manner as the Initial Elected Board. The directors shall continue to be so designated and elected at each subsequent annual members' meeting until such time as the Unit Owners other than the Developer are entitled to elect not less than a majority of the members of the Board of Directors. The Developer reserves the right, until such time as Unit Owners other than the Developer are entitled to elect not less than a majority of the members of the Board of Directors, to designate successor directors to fill any vacancies caused by the resignation or removal of directors designated by the Developer pursuant to this Subsection 4.3.3.

4.3.4. Unit Owners other than Developer are entitled to elect not less than a majority of the members of the Board of Directors of the Association upon the earlier of: (a) three years after fifty percent (50%) of the Units that will be operated ultimately by the Association have been conveyed to purchasers; (b) three months after ninety percent (90%) of the Units that will be operated ultimately by the Association have been conveyed to purchasers; (c) when all the Units that will be operated ultimately by the Association have been completed, some of them have been conveyed to purchasers, and none of the others are being offered for sale by Developer in the ordinary course of business; (d) when some of the Units have been conveyed to purchasers and none of the others are being constructed or offered for sale by Developer in the ordinary course of business; (e) seven years after recordation of the Declaration of Condominium; or (f) Developer so declaring by written notice to the members. Developer is entitled to elect at least one member of the Board of Directors as long as Developer holds for sale in the ordinary course of business at least five percent (5%) of the total Units in the Condominium. Following the time that Developer relinquishes control of the Association, Developer may exercise the right to vote any units owned by Developer in the same manner as any other Unit Owner except for purposes of reacquiring control of the Association or selecting the majority members of the Board of Directors.

4.4. TERM OF SERVICE. The term of each Board member's service, except in the case of a vacancy caused by recall, shall extend until the next annual meeting of the members and subsequently until their successor is duly elected and qualified or until a Board member is recalled in the manner provided in the Condominium Act by a majority of the Voting Members entitled to elect such Board member. Notwithstanding the foregoing, any Director designated by the Developer shall serve at the pleasure of the Developer and may be removed and replaced by the Developer at any time. A Board member appointed by the Board of Directors to replace a recalled Board member shall fill the vacancy until the next regularly scheduled election for any position. A seat held by a Board member who ceases to be an owner shall thereby automatically become vacant.

4.5. REMOVAL OF DIRECTORS AND BOARD VACANCIES. Any director elected by the Voting Interests may be recalled and removed, with or without cause, in the manner provided in the Condominium Act. Any director whose removal is sought shall be given notice prior to any meeting called for that purpose in the manner provided in the Condominium Act. Vacancies in the Board of Directors occurring between annual meetings of Unit Owners shall be filled by appointment by a majority vote of the remaining Board of Directors; provided, however, that if a majority or more of the Board members are removed by recall, the vacancies shall be filled in accordance with Rule 61B-23.0027 (if at a meeting) or with Rule 61B-23.0028 (if by written agreement) of the Florida Administrative Code; provided further that a Board member who has been recalled by the Unit Owners may not be appointed to fill the vacancy created by his or her removal; and further provided that following relinquishment of Developer control during the time that both the Developer and Unit Owners other than the Developer have representation on the Board of Directors pursuant to Section 718.301(1)(e) of the Condominium Act, the Developer-appointed Board members may not vote on selecting the majority members of the Board of Directors. A Board member elected or appointed to fill a vacancy shall be elected or appointed for a term specified by law.

4.6. ORGANIZATIONAL MEETING. The organizational meeting of each newly elected Board of Directors to elect officers shall be properly noticed pursuant to Section 718.112(2)(c) of the Condominium Act and held at such place and time as shall be fixed by the Board of Directors, provided a quorum shall be present. Unless otherwise noticed, it shall be held immediately following the annual meeting.

4.7. REGULAR MEETINGS. Regular meetings of the Board of Directors may be held at such time and place as shall be determined from time to time by a majority of the Board of Directors. Notice of regular meetings, unless noticed previously, shall be given to each Board member personally, by electronic transmission or by mail, telephone or telecopier at least forty-eight (48) hours prior to the day named for such meeting.

4.8. SPECIAL MEETINGS. Special meetings of the Board of Directors may be called by the President and must be called by the Secretary at the written request of any two (2) Board members. Not less than forty-eight (48) hours' notice of the meeting (except in an emergency) shall be given personally, by electronic transmission or by mail, telephone or telecopier, which notice shall state the time, place and purpose of the meeting.

4.9. WAIVER OF NOTICE. Any Board member may waive notice of a meeting before, at or after the meeting and such waiver shall be deemed equivalent to the giving of notice. Attendance by a Board member at a meeting shall constitute waiver of notice of the meeting.

4.10. NOTICE TO OWNERS. Notices of Board of Directors' meetings, and meetings of committees to take final action on behalf of the Board of Directors or, to make recommendations regarding the Association budget, shall be posted conspicuously on the Condominium Property at least forty-eight (48) continuous hours preceding the meeting, except in an emergency. Notices shall specifically incorporate an identification of agenda items. Meetings at which a regular assessment is to be considered shall contain a statement that assessments will be considered and the nature of such assessments. Written notice of any meeting at which non-emergency special assessments, or at which amendment to rules regarding unit use will be considered shall be mailed, delivered or electronically transmitted to the Unit Owners and posted conspicuously on the Condominium Property not less than fourteen (14) days prior to the meeting. Evidence of compliance with this fourteen (14) day notice shall be by an affidavit executed by the person providing the notice and filed among the official records of the Association. Upon prior notice to the Unit Owners, the Board of Directors shall by duly adopted rule designate a specific location on the Condominium Property, upon which all notices of Board of Directors' meetings shall be posted. The Board of Directors, upon notice to Unit Owners, shall, by duly adopted rule, designate a specific location on the Condominium Property or Association Property upon which all notices of Unit Owner meetings shall be posted. If there is no Condominium Property or Association Property upon which notices can be posted, notices of Board of Directors meetings shall be mailed, delivered or electronically transmitted to each Unit Owner at least fourteen (14) days before the meeting. In lieu of or in addition to the physical posting of notice of any meeting of the Unit Owners on the Condominium Property, the Association may, by reasonable rule, adopt a procedure for conspicuously posting and repeatedly broadcasting the notice and the agenda on a closed-circuit cable television system serving the Association. However, if broadcast notice is used in lieu of a notice posted physically on the Condominium Property, the notice and agenda must be broadcast at least four times every broadcast hour of each day that a posted notice is otherwise required by Section 718.112(c) of the Condominium Act. When broadcast notice is provided, the notice and agenda must be broadcast in a manner and for a sufficient continuous length of time so as to allow an average reader to observe the notice and read and comprehend the entire content of the notice and the agenda.

4.11. OWNER PARTICIPATION. Meetings of the Board of Directors and committee meetings for which notice is required pursuant to Section 4.10 above, at which a quorum of the members of the Board of Directors or committee, as applicable, are present, shall be open to all Unit Owners. The right to attend such meetings includes the right to speak with reference to all identified agenda items; provided, however, the Association may adopt reasonable rules governing the frequency, duration and manner of Unit Owner's statements. Unit Owners shall have the right to tape record or

videotape the meetings of the Board of Directors or committee, subject and pursuant to rules adopted from time to time by the Division of Florida Land Sales, Condominiums and Mobile Homes.

4.12. BOARD MEETINGS, QUORUM AND VOTING. A quorum at Board of Directors' meetings shall consist of a majority of the Board of Directors. The acts approved by a majority of Board of Directors present at a meeting, at which a quorum is present, shall constitute the acts of the Board of Directors. The Board of Directors may not vote by proxy or by secret ballot at Board of Directors' meetings, except as may be provided by the Condominium Act from time to time, and a vote or abstention for each member present shall be recorded in the minutes. If at any meeting of the Board of Directors there shall be less than a quorum of Board members present, the Board member(s) present may adjourn the meeting from time to time until a quorum is present. At any adjourned meeting, which must be properly noticed, any business which might have been transacted at the meeting as originally called may be transacted. Absent Board members may later submit in writing his/her agreement or disagreement with Board actions, but such statements may not be used for purposes of creating a quorum and may not be used as a vote for or against any action taken at the meeting.

4.13. PRESIDING OFFICER. The presiding officer at Board of Directors' meetings shall be the President, if such an officer has been elected; and if none, then the Vice President shall preside. In the absence of the presiding officer, the Board members present shall designate one of the Board members present to preside.

4.14. DIRECTOR COMPENSATION. Board members shall serve without pay, unless the Voting Interests annually authorize Board members' fees. Board members shall be entitled to reimbursement for expenses reasonably incurred.

5. POWERS AND DUTIES OF THE BOARD OF DIRECTORS. All of the powers and duties of the Association existing under the Florida Not-For-Profit Corporation Statute, the Condominium Act, the Declaration of Condominium, Articles of Incorporation and these By-laws shall be exercised exclusively by the Board of Directors, or its duly authorized agents, contractors, or employees subject only to the approval by Unit Owners when such is specifically required. Such powers and duties of the Board of Directors shall include, but shall not be limited to, the following:

5.1. TO ADOPT BUDGETS, BORROW MONEY AND MAKE AND COLLECT ASSESSMENTS AND FEES from and against Unit Owners and users to defray the expenses of the Association.

5.2. TO USE THE PROCEEDS OF ASSESSMENTS in the exercise of its powers and duties.

5.3. TO MAINTAIN, REPAIR, REPLACE AND OPERATE the Condominium Property.

5.4. TO ENACT AND AMEND RULES AND REGULATIONS concerning the use of the Common Elements and the Units subject to any limitations contained in the Condominium Act and the Declaration of Condominium.

5.5. TO RECONSTRUCT COMMON ELEMENT IMPROVEMENTS AFTER CASUALTY and to further improve the properties.

5.6. TO APPROVE OR DISAPPROVE PROPOSED ACTIONS in the manner provided by the Declaration of Condominium.

5.7. TO ENFORCE by legal means the provisions of applicable laws and the Condominium documents.

5.8. TO CONTRACT FOR MANAGEMENT of the Condominium.

5.9. TO CARRY INSURANCE for the protection of the Unit Owners, users, the Association and the Condominium Property.

5.10. TO PAY THE COST OF ALL UTILITY SERVICES rendered to the Condominium and not billed to Unit Owners or users.

5.11. TO EMPLOY AND DISMISS PERSONNEL and designate other officers for reasonable compensation and grant them such duties as seem appropriate for proper administration of the purposes of the Association.

5.12. TO BRING AND DEFEND SUITS, MAKE AND EXECUTE CONTRACTS, DEEDS, MORTGAGES, LEASES, LICENSES and other instruments by its officers and to purchase, own, lease, convey and encumber real and personal property. To grant easements and licenses over the Condominium Property necessary or desirable for proper operation of the Condominium.

5.13. TO COMPLY WITH REQUIREMENTS FOR ENTERING CONTRACTS FOR PRODUCTS AND SERVICES - All contracts for the purchase, lease or renting of materials or equipment or for services, or such other contracts which are not to be fully performed within one (1) year, shall be in writing. As to any such contract which requires payment exceeding five percent (5%) of the total annual budget of the Association including reserves except for contracts with employees of the Association, and for attorneys, accountants, community association managers, architects, engineers and landscape architects, the Association shall obtain competitive bids unless the products and services are needed as the result of an emergency or unless the desired supplier is the only source of supply within Duval County, Florida. The Association need not accept the lowest bid. This Section shall be deemed to incorporate the provisions of the Condominium Act as it exists from time to time.

5.14. TO LEVY FINES - The Board of Directors may, pursuant to Section 718.303 of the Condominium Act, impose fines not to exceed \$100.00 per violation, for failure to comply with the provisions of the Declaration of Condominium, the Articles of Incorporation, these By-Laws or the reasonable rules and regulations of the Association, by Owners, occupants, licensees, tenants, guests and invitees. A fine may be imposed for each day of continuing violation with a single notice and opportunity for hearing, provided that no fine shall in the aggregate exceed \$1,000.00.

5.14.1. HEARING NOTICE. The party against whom the fine is sought to be levied shall be afforded an opportunity for hearing after reasonable notice of not less than fourteen (14) days. Said notice shall include:

- (a) A statement of the date, time and place of the hearing;
- (b) A statement of the provisions of the Declaration, Articles of Incorporation, By-Laws, or Rules and Regulations which have allegedly been violated; and
- (c) A short and plain statement of the matters asserted by the Association.

5.14.2. RESPONDENT'S RIGHTS. The party against whom the fine or sanction may be levied shall have an opportunity to respond, to present evidence, and to provide written and oral argument on all issues involved and shall have an opportunity at the hearing to review, challenge, and respond to any material considered by the Association.

5.14.3. HEARING COMMITTEE. The hearing must be held before a committee of other Unit Owners, none of whom are members or spouses of the Board of Directors. If the committee does not agree with the fine, the fine may not be levied.

5.15. TO APPOINT COMMITTEES. The Board of Directors may appoint committees, except that a committee for the purpose of nominating candidates for election to the Board of Directors is prohibited. The Board of Directors may, however, appoint a search committee to encourage qualified persons to become candidates for the Board of Directors. All committees and committee members shall serve at the pleasure of the Board of Directors.

5.16. TO MAINTAIN FIRE SAFETY COMPLIANCE. The Board of Directors may accept a certificate of compliance from a licensed electrical contractor or electrician as evidence of compliance of the Units with the applicable fire and life safety code.

5.17. TO ADOPT SPECIFICATIONS FOR LAMINATED GLASS OR WINDOW FILM. The Board of Directors shall adopt specifications for laminated glass or window film architecturally designed to function as hurricane protection which equal or exceed the specifications of the original glass installed in the building and which comply with the applicable building code. The Board shall not refuse to approve the installation or replacement of laminated glass or window film conforming to the specifications adopted by the Board. Condominium residence exterior glass windows and sliding glass doors are a special architect approved laminated glass and have been designed and installed to meet or exceed the wind load and wind-borne debris impact standards of the applicable building code for hurricane protection. For this reason and for the purpose of preserving the aesthetic appearance of the building, hurricane shutters shall not be installed on any windows or sliding glass doors in the condominium residences. If such windows and sliding glass doors in the condominium residences are replaced, they must be replaced with laminated architectural glass equal to or exceeding the specifications of the original glass and which comply with the applicable building code.

5.18. TO HAVE THE FOLLOWING EMERGENCY POWERS. The following shall apply to the extent not viewed to be in conflict with the Condominium Act:

5.18.1. In anticipation of or during any emergency defined in Section 5.18.6 below, the Board of Directors of the Association may:

(a) Name as assistant officers persons who are not Board members, which assistant officers shall have the same authority as the executive officers to whom they are assistant, during the period of emergency, to accommodate the incapacity or unavailability of any officer of the Association; and

(b) Relocate the principal office or designate alternative principal offices or authorize the officers to do so.

5.18.2. During any emergency defined in Section 5.18.6. below:

(a) Notice of a meeting of the Board of Directors need be given only to those Board members whom it is practicable to reach and may be given in any practicable manner, including by publication and radio; and

(b) The Board member or members in attendance at a meeting shall constitute a quorum.

5.18.3. Corporate action taken in good faith during an emergency under this Section to further the ordinary affairs of the Association:

(a) Binds the Association; and

(b) Shall have the presumption of being reasonable and necessary.

5.18.4. An officer, director, employee or agent of the Association acting in accordance with these emergency By-Laws provisions is only liable for willful misconduct.

5.18.5. The provisions of these emergency By-Laws shall supersede any inconsistent or contrary provisions of the By-Laws for the period of emergency.

5.18.6. An emergency exists for purposes of this Section if a quorum of the Association's Board of Directors cannot readily be assembled because of some catastrophic or unforeseen event.

5.19. TO CONVEY TO CONDEMNING AUTHORITIES. To convey a portion of the Common Elements to a condemning authority for the purpose of providing utility easements, right of way expansion, or other public purposes, whether negotiated or as the result of eminent domain proceedings.

6. OFFICERS

6.1. OFFICERS OF THE ASSOCIATION. The affairs of the Association shall be administered by the officers of the Association. The officers of the Association shall be the President, one (1) or more Vice Presidents, a Secretary, a Treasurer, and such assistant officers as may be desired. The officers shall be elected by the Board of Directors of the Association at its first meeting following the annual meeting of the members of the Association and shall serve at the pleasure of the Board of Directors. Any officer may be preemptorily removed by a majority vote of the Board of Directors at any meeting. Any person may hold two (2) or more offices except that the President shall not also be the Secretary.

6.2. PRESIDENT; POWERS AND DUTIES. The President shall be the chief executive officer of the Association and shall have all of the powers and duties which are usually vested in the office of President of a corporation and shall exercise such other powers and perform such other duties as shall be prescribed by the Board of Directors.

6.3. VICE PRESIDENT; POWERS AND DUTIES. The Vice President shall, in the absence or disability of the President, exercise the powers and perform the duties of the President. The Vice President shall also generally assist the President and exercise such other powers and perform such other duties as shall be prescribed by the Board of Directors.

6.4. SECRETARY; POWERS AND DUTIES. The Secretary shall keep the minutes of all meetings of the Board of Directors and the Unit Owners; shall attend to the giving and serving of all notices to the Board members and Unit Owners and other notices required by law; shall have custody of the seal of the Association and affix the same to instruments requiring a seal when duly signed; shall keep and have custody of the records of the Association, except those of the Treasurer; and shall perform all other duties incident to the office of Secretary of the Association and as may be required by the Board of Directors or the President.

6.5. TREASURER; POWERS AND DUTIES. The Treasurer shall have custody of all property of the Association, including funds, securities and evidences of indebtedness; shall keep the assessment rolls and accounts of the Unit Owners; shall keep the books of the Association in accordance with good accounting practices; and shall perform all other duties incident to the office of the treasurer of a corporation and as may be prescribed by the Board of Directors.

6.6. EMPLOYEE COMPENSATION. The compensation of all employees of the Association shall be fixed by the Board of Directors. This provision shall not preclude the Board of Directors from employing a Board member as an employee of the Association.

6.7. INDEMNIFICATION. The Association shall indemnify its directors, officers and committee members and may indemnify its employees and agents, to the fullest extent permitted by law, against any and all expenses or liabilities incurred in defending civil, criminal or administrative proceedings resulting from the performance or attempted performance in good faith of their offices on behalf of the Association or its members. Such indemnification shall include advancement of expenses prior to the final disposition of any such proceedings and amounts paid in settlement of such proceedings, and such indemnification shall not be deemed exclusive of any other rights to which those indemnified may be entitled under any document other than this Declaration of Condominium, by vote of the members or disinterested directors, or otherwise. This indemnification shall continue as to a person who has ceased to be a director, officer, committee member, employee or agent, and shall inure to the benefit of his or her heirs and personal representatives. Anything to the contrary herein notwithstanding, no amendment to the provisions of this Section 6.7 shall be applicable as to any party eligible for indemnification hereunder who has not given his or her prior written consent to such amendment.

6.8. DELEGATION. To the extent permitted by law, the powers and duties of the Board of Directors and officers may be delegated for the purpose of management.

7. MINUTES AND INSPECTION OF RECORDS. Minutes of all meetings of Unit Owners and of the Board of Directors shall be kept in a businesslike manner and shall be reduced to written form within thirty (30) days and these, plus records of all receipts and expenditures and all other official records, as defined in Section 718.111 of the Condominium Act, except those which may be exempted by the Condominium Act and/or the rules of the Division of Florida Land Sales, Condominiums and Mobile Homes from time to time, shall be available for inspection by Unit Owners and Board members within five (5) working days after receipt of a written request by the Board member, its designee or a Unit Owner. This provision shall be deemed to have been complied with by having a copy of the official records available for inspection or copying on the Condominium Property or Association Property; provided, however, that the Board of Directors may adopt, in advance and in written form, reasonable rules regarding the frequency, time, location, notice and manner of record inspections and copying.

8. FISCAL MANAGEMENT. Fiscal management of the Association shall be in accordance with the following provisions:

8.1. BUDGET. A proposed annual budget of Common Expenses shall be prepared by the Board of Directors which shall include all anticipated expenses for operation, maintenance and administration of the Condominium, including insurance and management fees, if any, and for all of the unpaid operating expenses previously incurred. The proposed annual budget of Common Expenses shall be detailed and shall show the amounts budgeted by accounts and expense classifications, including, if applicable, but not limited to, those expenses listed in Section 718.504(21) of the Condominium Act. It shall include reserve accounts pursuant to Section 718.112(2)(F)(2) of the Condominium Act that may later be waived or reduced by a majority vote at a duly called meeting of the Association. Reserve funds and any accrued interest on the funds shall remain in the reserve account and shall be used only for authorized reserve expenditures, unless their use for other purposes is approved in advance by a vote of the majority of the applicable Voting Interests voting in person or by proxy at a duly called meeting of the Association. The budget will contain a reasonable allowance for contingencies and provide funds for all unpaid operating expenses previously incurred. If at any time a budget shall prove insufficient, it may be amended by the Board of Directors for the remaining portion of the fiscal year.

8.2. NOTICE OF BUDGET MEETING. At least fourteen (14) days prior to the meeting of the Board of Directors at which the budget will be considered, the Board of Directors shall hand deliver to each Unit Owner, or mail to each Unit Owner at the address last furnished to the Association by the Unit Owner, or electronically transmit to the location furnished by the Unit Owner for that purpose, a notice of the meeting together with a copy of the proposed annual budget. An officer or manager of the Association, or other person providing notice of such meeting, shall execute an affidavit evidencing compliance with such notice requirement, and such affidavit shall be filed among the official records of the Association.

8.3. ASSESSMENTS. Assessments shall be made against Units on a monthly basis in an amount which is not less than that required to provide funds in advance for payment of all the anticipated current operating expenses and for all of the unpaid operating expenses previously incurred. Assessments shall become due on the first day of each such period and shall become delinquent if not received ten (10) days thereafter. The Association shall have the right to accelerate assessments of any Unit Owner that is delinquent in the payment of Common Expenses. Accelerated assessments shall be due and payable on the date a claim of lien is filed in the Public Records of Duval County, Florida and shall include the amounts due for the remainder of the fiscal year for which the claim of lien was filed.

8.4. SPECIAL ASSESSMENTS AND CHARGES. Assessments and charges for expenses which are not provided for and funded in the operating budget shall be made by the Board of Directors, and the time of payment shall likewise be determined by them.

8.5. ASSESSMENT ROLL. The Assessments for Common Expenses and charges shall be set forth upon a roll of the Units which shall be available for inspection at all reasonable times by Unit Owners. Such roll shall indicate for each Unit the name and address of the Unit Owner, and the Assessments and charges paid and unpaid. A certificate made by a duly authorized representative of or by the Board of Directors as to the status of a Unit's account may be relied upon for all purposes by any person for whom made.

8.6. LIABILITY FOR ASSESSMENTS. A Unit Owner regardless of how his or her title has been acquired, including by purchase at a foreclosure sale or by deed in lieu of foreclosure, shall be liable for all Assessments coming due while the owner of a Unit. Additionally, a Unit Owner shall be jointly and severally liable with the previous owner for all unpaid Assessments due and payable

up to the time of transfer of title. Liability may not be avoided by waiver of the use or enjoyment of any Common Elements or Association Property or by abandonment of the unit for which the Assessments are made. The liability of a first mortgagee or its successor or assignees who acquire title to a Unit by foreclosure or by deed in lieu of foreclosure for the unpaid Assessments that became due prior to the mortgagee's acquisition of title is limited to the lesser of: (1) the Unit's unpaid Common Expenses and regular periodic Assessments which accrued or came due during the six (6) months immediately preceding the acquisition of title and for which payment in full has not been received by the Association; or (2) one percent (1%) of the original mortgage debt. This limitation shall not apply unless the first mortgagee joined the Association as a defendant in the foreclosure action. Joinder of the Association is not required if, on the date the complaint is filed, the Association was dissolved or did not maintain an office or agent for service of process at a location which was known to, or reasonably discoverable by the mortgagee. The person acquiring title shall pay the amount owed to the Association within thirty (30) days after transfer of title. Failure to pay the full amount of all Assessments when due shall entitle the Association to record a claim of lien against the parcel and proceed in the same manner as provided in this Section for the collection of unpaid assessments. This Section shall be deemed amended so as to incorporate the provisions of Section 718.116 of the Condominium Act as amended from time to time.

8.7. LIENS FOR ASSESSMENTS. The unpaid portion of an assessment including an accelerated assessment which is due, together with costs, interest and reasonable attorneys' fees for collection, shall be secured by a lien upon the unit and all appurtenances thereto when a notice claiming the lien has been recorded by the Association in accordance with the requirements of Section 718.116 of the Condominium Act.

8.8. UNPAID CHARGES. Unpaid charges which are due together with costs, interest and reasonable attorneys' fees including appeals for collection shall be the basis for an action at law by the Association against the Unit Owner.

8.9. COLLECTION; INTEREST; ADMINISTRATIVE LATE FEE; APPLICATION OF PAYMENTS. Assessments paid on or before ten (10) days after the date due shall not bear interest, but all sums not paid on or before ten (10) days shall bear interest at the highest lawful rate from time to time (now eighteen percent (18%) per annum) from the date due until paid. In addition to such interest the Association may charge an administrative late fee in an amount not to exceed the greater of \$25.00 or five percent (5%) of each installment of the Assessment for which payment is late. All payments upon account shall be first applied to interest, then the late fee, then to any costs and reasonable attorneys' fees and then to the Assessment payment first due. All interest collected shall be credited to the common expense account.

8.10. COLLECTION; SUIT. The Association, at its option, may enforce collection of delinquent Assessments by suit at law, by foreclosure of the lien securing the Assessments, or by any other remedy available under the laws of the State of Florida, and in any event the Association shall be entitled to recover the payments which are delinquent at the time of collection, judgment or decree, together with those which have become due by acceleration plus interest thereon and all costs incident to the collection and the proceedings, including reasonable attorneys' fees, including appeals. The Association must deliver or mail by certified mail to the Unit Owner a written notice of its intention to foreclose the assessment lien thirty (30) days before commencing foreclosure, unless a Notice of Contest of Lien has been filed. The lien created by Section 718.116(5)(a) of the Condominium Act shall secure only assessments, interest, costs and attorneys fees and not fines, charges or other fees.

8.11. ACCOUNTS. All sums collected from Assessments or charges shall be credited to accounts from which shall be paid the expenses for which the respective Assessments or charges are made.

8.12. ASSOCIATION DEPOSITORY. The depository of the Association shall be a bank or banks or state or federal savings and loan associations or a member firm of the New York Stock Exchange with offices in Florida and as shall be designated from time to time by the Board of Directors and in which the monies for the Association shall be deposited. Withdrawal of monies from such accounts shall be only by checks signed by such persons as are authorized by the Board of Directors.

8.13. COMMINGLING OF FUNDS PROHIBITED. All funds shall be maintained separately in the Association's name. Reserve and operating funds may not be commingled unless combined for investment purposes. This Section 8.13 is not meant to prohibit prudent investment of Association funds even if combined with operating or other reserve funds of the Association, but such funds must be accounted for separately, and the combined account balance may not, at any time, be less than the amount identified as reserve funds in the combined account. No manager or business entity required to be licensed or registered under Florida Statutes Section 468.432 (2005), and no agent, employee, officer, or Board member of the Association shall commingle any Association funds with his or her funds or with the funds of any other condominium association or community association as defined in Florida Statutes Section 468.431 (2005).

8.14. ANNUAL FINANCIAL REPORT. Financial reports meeting the requirements of Section 718.111(13) of the Condominium Act shall be made annually within ninety (90) days after the end of the fiscal year of the Association. Within twenty-one (21) days after the annual financial report is completed by the Association or received from the third party, but not later than one hundred twenty (120) days after the end of the fiscal year, the Association shall mail or hand deliver to each Unit Owner a copy of the financial report or a notice that a copy of the financial report will be mailed or hand delivered to the Unit Owner, without charge, upon receipt of a written request from the Unit Owner.

9. FIDELITY BONDING. The Association shall obtain and maintain blanket fidelity bonding for each person who controls or disburses funds of the Association and the President, Secretary and Treasurer of the Association in an amount not less than \$50,000.00 for each person, but in no event less than the minimum required by the Condominium Act or FNMA/FMLMC from time to time based upon the maximum funds that will be in the custody of the Association or its management agent at any one time. The Association shall bear the cost of bonding, which shall be a Common Expense.

10. PARLIAMENTARY RULES. A parliamentary procedure such as Robert's Rules of Order uniformly applied shall govern the conduct of corporate proceedings when not in conflict with the Declaration, the Articles of Incorporation or By-Laws of the Association or with the laws of the State of Florida.

11. BY-LAW AMENDMENTS. Amendments to the By-Laws shall be adopted in the following manner:

11.1. NOTICE of the proposed amendment or text of the proposed amendment shall be included in the notice of any meeting at which or by which a proposed amendment is considered.

11.2. PROPOSAL OF AMENDMENTS - An amendment may be proposed by either a majority of the Board of Directors or by twenty-five percent (25%) of the Voting Interests of the Association.

11.3. ADOPTION OF AMENDMENTS - After turnover, a resolution or written agreement adopting a proposed amendment must receive approval of sixty-seven percent (67%) of the

Voting Interests for the amendment to be adopted. Prior to turnover, amendments may be adopted by a majority of the Board of Directors alone, without vote of the Unit Owners.

11.4. EFFECTIVE DATE - An amendment when adopted shall become effective only after being recorded in the Public Records of Duval County, Florida.

11.5. PROPOSED AMENDMENT FORMAT - Proposals to amend existing By-Laws shall contain the full text of the By-Laws to be amended. New words shall be underlined and words to be deleted shall be lined through with hyphens. If, however, the proposed change is so extensive that this procedure would hinder rather than assist understanding, a notation may be inserted instead immediately preceding the proposed amendment saying, "SUBSTANTIAL REWORDING OF BY-LAW. SEE BY-LAW NUMBER FOR PRESENT TEXT."

12. MANDATORY ARBITRATION OF DISPUTES. Any unresolved disputes between the Board of Directors and Unit Owners, as defined in Section 718.1255(1) of the Condominium Act, must be arbitrated in mandatory non-binding arbitration proceedings as required by the Condominium Act prior to commencing litigation.

13. ELECTRONIC TRANSMISSION. For purposes hereof, "electronic transmission" means any form of communication, not directly involving the physical transmission or transfer of paper, which creates a record that may be retained, retrieved and reviewed by a recipient thereof and which may be directly reproduced in a comprehensible and legible paper form by such recipient through an automated process. Examples of electronic transmission include, but are not limited to, telegrams, facsimile transmissions of images, and text that is sent via electronic mail between computers. Notwithstanding the provision for electronic transmission of notices by the Association, same may only be sent to Unit Owners that consent to receipt of Association notices by electronic transmission (and only for so long as such consent remains in effect). Further, in no event may electronic transmission be used as a method of giving notice of a meeting called in whole or in part regarding the recall of a Director.